

Check valves type CRK, CRB and CRH

to screw-in into simple to manufacture tapped holes

Pressure p_{max} = 500 bar
 Flow Q_{max} = 80 lpm

Other valves with similar lay-out:

- | | |
|---|-----------|
| ● Pressure valves type CMV, GSV | D 7710 MV |
| ● Pressure controlled 2-way directional valve type CNE | D 7710 NE |
| ● Check valves and throttles type CAV | D 7711 |
| ● Throttle and restrictor check valves type CQ, CQR and CQV | D 7713 |
| ● Flow control valves type CSJ | D 7736 |
| ● Pressure reducing valves type CDK | D 7745 |
| ● Pressure-dependent shut-off valves type CDSV | D 7876 |

1. General information

These check valves fall into two groups:

- Check valves type CRK (B) and
- Releasable check valves type CRH.

In principle all these valves are to be screwed into simply shaped tapped holes of a manifold body. The sealing of the inlet to the outlet takes place at the contact area between the facial sealing edge of the screwed-in end of the valve body and the stepped shoulder of the core diameter the location thread. Any standard steel drill (point angle 118°) automatically forms this stepped shoulder when the core diameter is drilled. Therefore reaming of the hole and bevels to help the seals slip in are not necessary.

The sealing of the attached valve and its fixing at the manifold body are via a sealing nut featuring a special thread seal and an O-ring.

● Check valves type CRK and CRB

These valves enable free flow in one direction and block flow in opposite direction. Type CRK blocks in direction of $B \rightarrow A$, type CRB in direction of $A \rightarrow B$.

For system pressure up to 500 bar and max. flow from 30, 50 and 80 lpm (depending on size). Their field of application are all standard control purposes within hydraulic circuits where directional valves are operated more or less regularly. These check valves must not be utilized in circuits with a high frequent load changes.

● Releasable check valves type CRH

These valves enable free flow in direction $B \rightarrow A$ and block it in direction $A \rightarrow B$. The blocked flow direction $A \rightarrow B$ may be opened hydraulically (released)

For system pressure up to 500 bar and max. flow of 20, 30 and 55 lpm (depending on size).

Application:

To block circuits with zero leakage where leakagefree hydraulic cylinders are used together with directional spool valves with inherent leakage.

As return flow aid: If the return flow of a double acting cylinder exceeds the permissible flow of the directional valve, due to unequal area ratios, during retracting operations. As a hydraulically drain or idle circulation valve.

The full flow cross-section is quickly opened, when the valve is hydraulically released. The diameter of the control duct in the manifold body should be quite small, giving the same effect as a throttling pipe. This prevents pressure surges, when the valve is quickly opened at high pressure. The throttling section is located in the inlet Z of valves size 3.

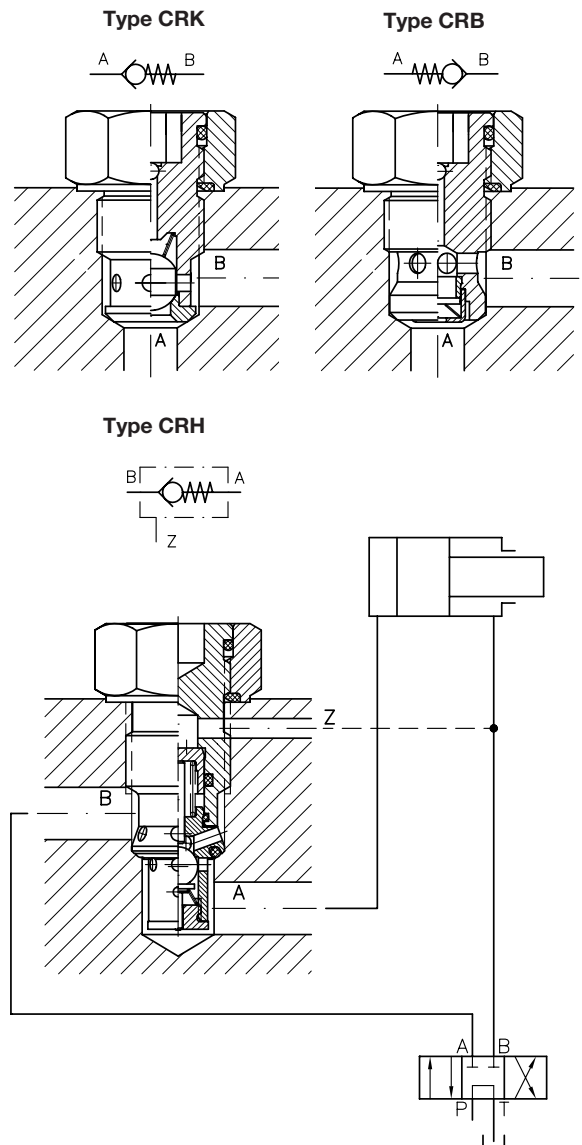

Size 3 is also available with pre-release for high pressure and high consumer volumes. A small check valve is opened, sufficiently and smoothly reducing the pressure via the throttle section within the consumer before the main valve is opened. An additional throttle within the control duct increases the effectivity of the pre-release.



2. Available versions, main data

Order examples: **CRK 1 - 1/4** Check valve
 Version with connection block (only with type CRK 1 and CRB 1)
 Ports A and B ISO 228/1 (BSPP)
 - 1/4 = G 1/4
 - 3/8 = G 3/8

CRH 2 Releasable check valve
CRH 3 V Releasable check valve with pre-release

Nomenclature and symbol	Basic type and size	Pres- sure p_{max} (bar)	Flow Q_{max} approx. (lpm)	Release ratio		Tapped journal metric ISO-fine thread DIN 13 T6	Max. torque	
				Main - valve	Pre- release		Valve body (Nm)	Sealing nut (Nm)
Check valve Check valve thread direction ↓	 CRK 1 CRK 1/1,3 CRK 2 CRK 3	500	30	---	---	M 16x1.5	40	35
			50	---	---	M 20x1.5	50	40
			80	---	---	M 24x1.5	70	60
	 CRB 1 CRB 2	500	30	---	---	M 16x1.5	40	35
			50	---	---	M 20x1.5	50	40
Releasable check valve ...3V is with pre-release 	CRH 1 CRH 11 ²⁾ CRH 2 CRH 21 ²⁾ CRH 3 CRH 31 ²⁾ CRH 3V ¹⁾ CRH 31V ²⁾	500	20	2.6:1	---	M 16x1.5	40	35
			30	2.6:1	---	M 20x1.5	50	40
			55	2.5:1	---	M 24x1.5	70	60
			55	2.5:1	10:1	M 24x1.5	70	60

1) Version with pre-relief

2) Version with additional thread and control piston seal

3. Further data

Nomenclature Spring loaded check valve cartridge
 Design Depending on type either ball seated or disc design
 Material Steel body gas nitrided, sealing nut zinc galvanized, internal functional parts hardened and ground, balls made of bearing quality steel

Installation position Any
 Port coding A, B = Consumer connections
 Z = Control connection with type CRH

Mass (weight) Only for circuit diagrams and assembly instructions, see schematic drawings sect. 1 or dimensional drawings sect. 4. The port codings are not stamped onto the valve body.
 Type CRK(B) 1 = 70 g Type CRH 1 = 60 g Connection block - 1/4 = +260 g
 CRK(B) 2 = 110 g CRH 2 = 90 g - 3/8 = +260 g
 CRK 3 = 130 g CRH 3(V) = 150 g

Static overload capacity Approx. $2 \times p_{max}$ at tightened state and with sealing nut locked

Leakage with type CRH 1(2,3) There is a negligible leakage between connections Z → B due to the thread clearance, but this doesn't effect the blocked consumer side A, not apparent with type CRH 11(21,31)

Direction of flow
 Type CRK: A → B free flow, B → A blocked state
 CRB: A → B blocked, B → A free flow state
 CRH: B → A free flow state
 A → B is blocked leakagefree in idle position (connection Z not pressurized), if pressure at B is none or lower than at A
 A → B free flow, if control pressure at Z opens the valve (also see control pres-sure p_{contr})

Pressure $p_{max} = 500$ bar see also sect. 2)
 Opening pressure Type CRK: approx. 0.5 bar (CRK 1/1.3: approx. 1.3 bar), Type CRB: approx. 0.07 ... 0.1 bar
 A → B resp. B → A CRH: approx. 0.5 bar
 Control pressure p_{contr} (guideline) with type CRH

For releasing

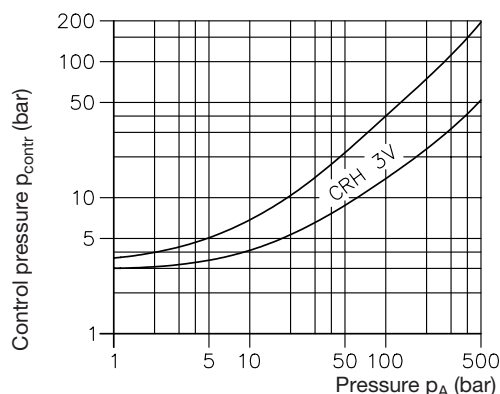

to maintain open position
 $p_{contr} = p_B + \Delta p + k$

p_B = pressure at B
 Δp = flow resistance A → B
 acc. to Δp -Q-curve

k = 4.5 type CRH 1
 4.0 type CRH 2
 2.5 type CRH 3

Pressure fluid Hydraulic oil conforming DIN 51524 part 1 to 3: ISO VG 10 to 68 conforming DIN 51519.
 Viscosity limits: min. approx. 4, max. approx. 1500 mm²/s;
 opt. operation approx. 10... 500 mm²/s.
 Also suitable are biologically degradable pressure fluids type HEPG (Polyalkylenglycol) and HEES (Synth. Ester) at service temperatures up to approx. +70°C.

Temperature Ambient: approx. -40 ... +80°C
 Fluid: -25 ... +80°C, Note the viscosity range !
 Permissible temperature during start: -40°C (observe start viscosity!), as long as the service temperature is at least 20K higher for the following operation.
 Biologically degradable pressure fluids: Observe manufacturer's specifications. By consideration of the compatibility with seal material not over +70°C.

Δp-Q curves

Viscosity during measurements approx. 60 mm²/s

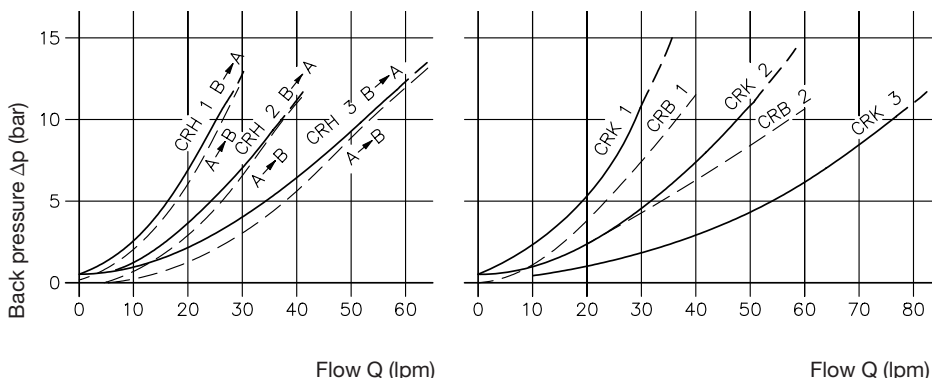

4. Unit dimensions

All dimension in mm and subject to change without notice!

4.1 Check valves type CRK and CRB

Version with connection block
 CRK1. (CRB1) - 1/4 (3/8)

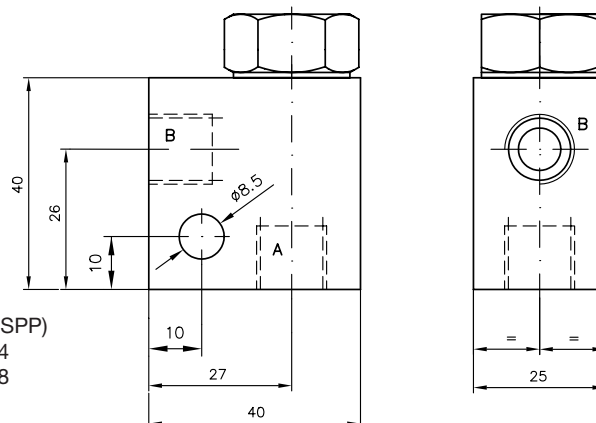
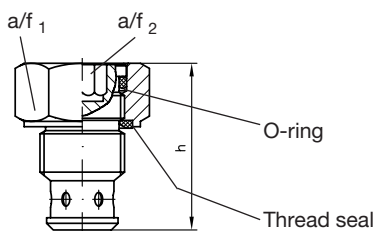

Ports A and B ISO 228/1 (BSPP)
 CRK 1 (CRB 1) - 1/4 = G 1/4
 CRK 1 (CRB 1) - 3/8 = G 3/8
 Surface zinc galvanized

Mounting hole

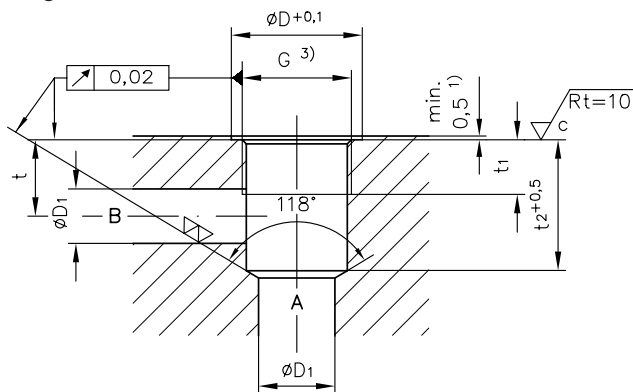

Note:

For tapped plugs for the mounting hole, see section 4.3

- 1) A sinking is required, if the pressure at B exceeds 100 bar!
- 2) This applies to manifolds made of steel, nodular cast iron or other common materials, e.g. light alloy.
- 3) Sinking_{max}

Ø16+0.2	type CRK1, CRB1
Ø20+0.2	type CRK2, CRB2
Ø24+0.2	type CRK3, CRB3

Type	G	D	D ₁	h	t	t ₁	t ₂	a/f 1	a/f 2	Max. torque (Nm) ²⁾		Thread seal	O-ring AU 90 Sh
										a/f 1	a/f 2		
CRK 1. CRB 1	M 16x1.5	22	8	31	13	11	18	22	8	35	40	KANTSEAL DKAR00016-N90	14x1.78
CRK 2 CRB 2	M 20x1.5	24	10	35	14	13	20	24	10	40	50	KANTSEAL DKAR00018-N90	17.17x1.78
CRK 3	M 24x1.5	30	11	38	16	13	22	30	12	60	70	KANTSEAL DKAR00021-N90	21.95x1.78

4.2 Check valves with hydraulic release type CRH

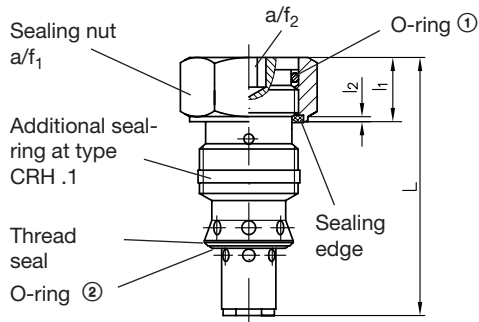

Type	L	l ₁	l ₂	a/f ₁	a/f ₂	Max. torque (Nm) ²⁾	
						a/f ₁	a/f ₂
CRH 1	47	12	1	22	8	35	40
CRH 2	53	13	1	24	10	40	50
CRH 3 CRH 3V	61	14	1.5	30	12	60	70

Type	Thread seal	O-ring ① AU 90 Sh	O-ring ② NBR 90 Sh	seal ring at CRH .1
CRH 1	KANTSEAL DKAR00016-N90	14x1.78	10x1.5	7735 003
CRH 2	KANTSEAL DKAR00018-N90	17.17x1.78	12.42x1.78	7735 013
CRH 3 CRH 3V	KANTSEAL DKAR00021-N90	21.95x1.78	15.3x2.4	7735 023

Mounting hole

Type CRH 1(2, 3, 3V)

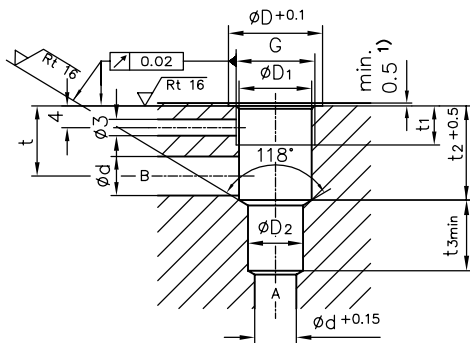

Type	G	Max. \varnothing thread chamfer								
			D	D ₁	D ₂	d	t	t ₁	t ₂	t ₃
CRH 1	M 16x1.5	16 ^{+0.2}	22	14.3	11	8	17	13	22	13
CRH 2	M 20x1.5	20 ^{+0.2}	24	18.3	14	10	18	15	24	17
CRH 3 CRH 3V	M 24x1.5	24 ^{+0.2}	30	22.3	16	11	21	16	28	19

Mounting hole

Type CRH 11(21,31, 31V)

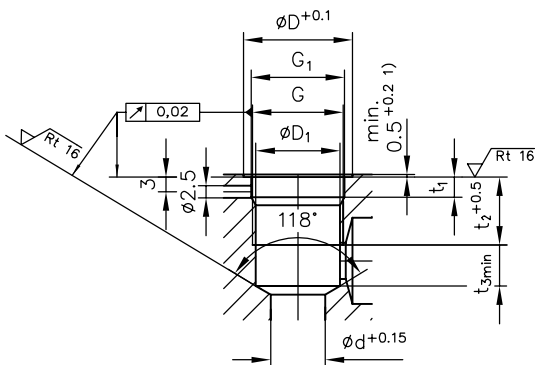

Type	G	G ₁ max. \varnothing thread chamfer						
			D	D ₁	d	t ₁	t ₂	t ₃
CRH 11	M 16x1.5	16.5	22	14.5	11	5	13	9
CRH 21	M 20x1.5	20.5	24	18.2	12	4.5	15	9
CRH 31(V)	M 24x1.5	24.5	30	22.5	16	5.5	16	12

Note:

For tapped plugs for the mounting hole, see below!

4.3 Tapped plugs

Mounting holes in the manifold may be blocked if required by tapped plugs, e.g. if uniform manufactured manifolds should be equipped with or without cartridge valves depending on application.

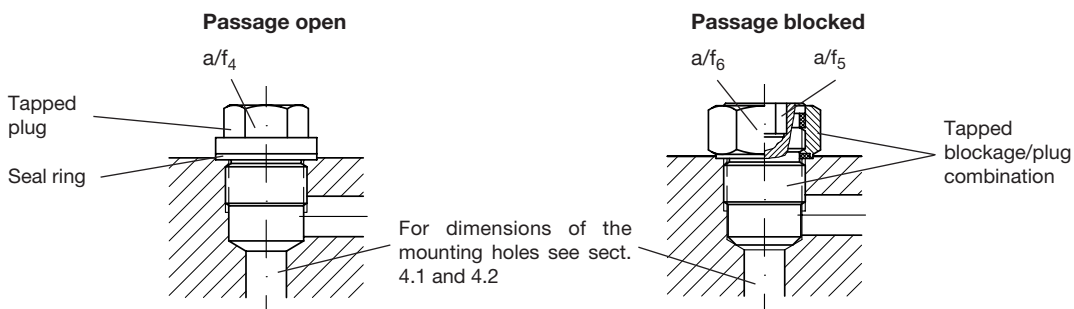

Type and size	Passage open			Seal ring DIN 7603-Cu	Passage blocked				
	Tapped plug		Max. torque (Nm) ²⁾		Tapped blockage/plug combination complete ³⁾				
	DIN 910	SW4			Drawing no.	Tapped part		Counter/sealing nut	
				a/fs	Max. torque (Nm) ²⁾	a/f6	Max. torque (Nm) ²⁾		
CRK 1. CRB 1	M 16x1.5	17	40	A 16x22x1.5	Z 7712 003	8	40	22	35
CRH 1 CRH 11					Z 7735 011				
CRK 2 CRB 2	M 20x1.5	19	50	A 20x24x1.5	Z 7712 013	10	50	24	40
CRH 2 CRH 21					Z 7715 019				
CRK 3	M 24x1.5	22	70	A 25x30x2	Z 7710 029	12	70	30	60
CRH 3 CRH 3V CRH 31 CRH 31V					Z 7715 029				
Mass (weight)					M 16x1.5 + seal ring = approx. 40 g				
	M 20x1.5 + seal ring = approx. 60 g	Z 7735 011 = approx. 65 g	Z 7710 029 = approx. 140 g						
	M 24x1.5 + seal ring = approx. 100 g	Z 7712 013 = approx. 85 g	Z 7715 029 = approx. 140 g						

1) A sinking is required, if the pressure at B exceeds 100 bar!

2) This applies to manifolds made of steel, nodular cast iron or other common materials, e.g. light alloy

3) For thread seals and O-rings see sect 4.1 and 4.2