

Piston type accumulator type HPS

Product documentation



Operating pressure p_{\max} : 350 bar
Nominal volume $V_{0 \max}$: 40 dm³



D 7969 HPS
04-2014-1.3

HAWE
HYDRAULIK

© by HAWE Hydraulik SE.

The forwarding and reproduction of this document, as well as the use and communication of its contents, are forbidden unless expressly permitted.

Any breach or infringement will result in liability for damages.

All rights reserved concerning patent or utility model registrations.

Contents

1	General Information piston type accumulators type HPS.....	4
2	Available versions, main data.....	5
2.1	Available Versions.....	5
3	Parameters.....	7
3.1	General.....	7
4	Dimensions.....	9
4.1	Piston type accumulator.....	9
5	Installation, operation and maintenance information.....	11
5.1	General notes.....	11
5.1.1	Safety instructions.....	11
5.1.2	Legal provisions.....	11
5.1.3	Transport and storage.....	12
5.2	Designated use.....	12
5.3	Assembly information.....	13
5.3.1	Installation and commissioning.....	13
5.4	Operating instructions.....	15
5.5	Maintenance information.....	15
5.5.1	Relieving pressure in piston type hydraulic accumulator and removing.....	15
5.5.2	Installing piston type accumulator.....	15
5.5.3	Checking gas filling pressure.....	15
6	Other information.....	16
6.1	Accessories, spare parts and separate components.....	16
6.2	Mounting brackets.....	17
6.3	Layout instructions.....	18

1**General Information piston type accumulators type HPS**

Piston type accumulators are a type of hydraulic accumulator. A freely moving piston separates the compressible gas cushion from the hydraulic fluid. The piston type accumulator type HPS supports or increases the pump delivery flow or stores pressure energy. It is used in clamping hydraulics to compensate for volume changes in the event of temperature fluctuations, to cover any leakage losses or to dampen oscillations. The piston type accumulator type HPS can be installed in different situations with the aid of suitable fastening clips.

Features and benefits:

- Compact design
- Option of integration into the HAWE modular system

Intended applications:

- Accumulator charging systems
- Construction machines
- Wind power plants
- Machine tools



Figure 1: Piston-type accumulators type HPS

2 Available versions, main data

2.1 Available Versions

Order coding example:

HPS 10	- 350	- 080	- 0040	- 160
				Gas pre-load pressure p_0 (bar)
			Nominal volume	Table 2 Nominal volume
		Inner diameter		Table 1 Basic type
	Operation pressure (bar)			Table 1 Basic type
Basic type				Table 1 Basic type

Table 1 Basic type

Basic type	Max. permissible operating pressure MWP (bar)	Available nominal volume V_0 (dm ³)	Inner diameter (mm)
HPS 10-350-050-...	350	0.1 ... 1.0	50
HPS 10-350-080-...		0.4 ... 4.0	80
HPS 10-350-100-...		2.0 ... 10.0	100
HPS 10-350-140-...		4.0 ... 25.0	140
HPS 10-350-160-...		6.0 ... 30.0	160
HPS 10-350-180-...		8.0 ... 40.0	180

For information on gas pre-load pressure, see [Chapter 6.3, "Layout instructions"](#)

For information on mounting brackets, see [Chapter 6.2, "Mounting brackets"](#)

Table 2 Nominal volume

Basic type	Coding	Nominal volume V_0 (dm ³)	Basic type	Coding	Nominal volume V_0 (dm ³)
HPS 10-350-050	0001	0.1	HPS 10-350-140	0040	4.0
	0002	0.2		0050	5.0
	0003	0.3		0060	6.0
	0004	0.4		0100	10.0
	0005	0.5		0120	12.0
	0007	0.7		0150	15.0
	0010	1.0		0200	20.0
HPS 10-350-080	0004	0.4	0250	25.0	
	0005	0.5	HPS 10-350-160	0060	6.0
	00075	0.75		0080	8.0
	0010	1.0		0100	10.0
	0015	1.5		0150	15.0
	0020	2.0		0200	20.0
	0030	3.0		0250	25.0
	0040	4.0		0300	30.0
HPS 10-350-100	0020	2.0		HPS 10-350-180	0080
	0030	3.0	0100		10.0
	0040	4.0	0120		12.0
	0060	6.0	0150		15.0
	0080	8.0	0200		20.0
	0100	10.0	0250		25.0
			0300		30.0
			0350		35.0
			0400		40.0

3 Parameters

3.1 General

Design	Hydraulic piston type accumulator according to the Pressure Equipment Directive 97/23/EG (PED), screwed end flanges
Max. operating/test pressure	350 bar / 501 bar
Surface	Painted black
Gas filling	N ₂ only (nitrogen)!
Temperature	Ambient: approx. -20 to +80°C, oil : -20°C to +80°C, pay attention to the viscosity range! Biologically degradable pressure fluids: note manufacturer specifications. With consideration for the seal compatibility, not above +70°C.
Hydraulic fluid	Hydraulic oil: conforming to DIN 51 524 Part 1 to 3; ISO VG 10 to 68 conforming DIN 51 519 Viscosity range: min. approx. 10, max. approx. 300 mm ² /s Optimal operating range: approx. 10 to 35 mm ² /s Also suitable for biologically degradable pressure fluids type HEPG (polyalkalene glycol) and HEES (synthetic ester) at operating temperatures up to approx. +70°C.
Lifetime	1.2 x 10 ⁹ cycles For all other operating conditions the service life in accordance with PD 5500 Annex C must be observed (Pressure Equipment Directive)

Weight

Type HPS 10 - 350 - 050

- 0001	= 1.9 kg
- 0002	= 2.2 kg
- 0003	= 2.6 kg
- 0004	= 3.0 kg
- 0005	= 3.3 kg
- 0007	= 4.0 kg
- 0010	= 5.0 kg

Type HPS 10 - 350 - 080

- 0004	= 5.7 kg
- 0005	= 6.0 kg
- 00075	= 6.8 kg
- 0010	= 7.6 kg
- 0015	= 9.2 kg
- 0020	= 10.8 kg
- 0030	= 14.1 kg
- 0040	= 17.3 kg

Type HPS 10 - 350 - 100

- 0020	= 14.8 kg
- 0030	= 17.4 kg
- 0040	= 19.9 kg
- 0060	= 24.9 kg
- 0080	= 30.0 kg
- 0100	= 35.1 kg

Type HPS 10 - 350 - 140

- 0040	= 33.3 kg
- 0050	= 35.7 kg
- 0060	= 38.1 kg
- 0100	= 47.7 kg
- 0120	= 52.5 kg
- 0150	= 59.7 kg
- 0200	= 71.7 kg
- 0250	= 83.7 kg

Type HPS 10 - 350 - 160

- 0060	= 48.9 kg
- 0080	= 53.1 kg
- 0100	= 57.3 kg
- 0150	= 67.6 kg
- 0200	= 78.1 kg
- 0250	= 88.5 kg
- 0300	= 99.0 kg

Type HPS 10 - 350 - 180

- 0080	= 68.3 kg
- 0100	= 73.0 kg
- 0120	= 77.6 kg
- 0150	= 84.6 kg
- 0200	= 96.3 kg
- 0250	= 107.9 kg
- 0300	= 119.6 kg
- 0350	= 131.3 kg
- 0400	= 143.0 kg

4 Dimensions

All dimensions in mm, subject to change!

4.1 Piston type accumulator

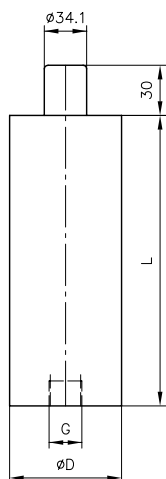

Type	D	L	G (ISO 228/1) (BSPP)
HPS 10 - 350 - 050 - 0001	60	130	G 3/4
HPS 10 - 350 - 050 - 0002	60	181	G 3/4
HPS 10 - 350 - 050 - 0003	60	232	G 3/4
HPS 10 - 350 - 050 - 0004	60	283	G 3/4
HPS 10 - 350 - 050 - 0005	60	334	G 3/4
HPS 10 - 350 - 050 - 0007	60	435	G 3/4
HPS 10 - 350 - 050 - 0010	60	588	G 3/4
Type	D	L	G (ISO 228/1) (BSPP)
HPS 10 - 350 - 080 - 0004	95	166	G 3/4
HPS 10 - 350 - 080 - 0005	95	186	G 3/4
HPS 10 - 350 - 080 - 00075	95	236	G 3/4
HPS 10 - 350 - 080 - 0010	95	286	G 3/4
HPS 10 - 350 - 080 - 0015	95	385	G 3/4
HPS 10 - 350 - 080 - 0020	95	485	G 3/4
HPS 10 - 350 - 080 - 0030	95	684	G 3/4
HPS 10 - 350 - 080 - 0040	95	883	G 3/4

Type	D	L	G (ISO 228/1) (BSPP)
HPS 10 - 350 - 100 - 0020	115	381	G 1
HPS 10 - 350 - 100 - 0030	115	509	G 1
HPS 10 - 350 - 100 - 0040	115	636	G 1
HPS 10 - 350 - 100 - 0060	115	891	G 1
HPS 10 - 350 - 100 - 0080	115	1146	G 1
HPS 10 - 350 - 100 - 0100	115	1400	G 1

Type	D	L	G (ISO 228/1) (BSPP)
HPS 10 - 350 - 140 - 0040	160	418	G 1 1/2
HPS 10 - 350 - 140 - 0050	160	483	G 1 1/2
HPS 10 - 350 - 140 - 0060	160	548	G 1 1/2
HPS 10 - 350 - 140 - 0100	160	808	G 1 1/2
HPS 10 - 350 - 140 - 0120	160	938	G 1 1/2
HPS 10 - 350 - 140 - 0150	160	1133	G 1 1/2
HPS 10 - 350 - 140 - 0200	160	1458	G 1 1/2
HPS 10 - 350 - 140 - 0250	160	1783	G 1 1/2

Type	D	L	G (ISO 228/1) (BSPP)
HPS 10 - 350 - 160 - 0060	180	490	G 1 1/2
HPS 10 - 350 - 160 - 0080	180	589	G 1 1/2
HPS 10 - 350 - 160 - 0100	180	689	G 1 1/2
HPS 10 - 350 - 160 - 0150	180	937	G 1 1/2
HPS 10 - 350 - 160 - 0200	180	1186	G 1 1/2
HPS 10 - 350 - 160 - 0250	180	1435	G 1 1/2
HPS 10 - 350 - 160 - 0300	180	1684	G 1 1/2

Type	D	L	G (ISO 228/1) (BSPP)
HPS 10 - 350 - 180 - 0080	205	496	G 1 1/2
HPS 10 - 350 - 180 - 0100	205	574	G 1 1/2
HPS 10 - 350 - 180 - 0120	205	653	G 1 1/2
HPS 10 - 350 - 180 - 0150	205	771	G 1 1/2
HPS 10 - 350 - 180 - 0200	205	968	G 1 1/2
HPS 10 - 350 - 180 - 0250	205	1164	G 1 1/2
HPS 10 - 350 - 180 - 0300	205	1361	G 1 1/2
HPS 10 - 350 - 180 - 0350	205	1557	G 1 1/2
HPS 10 - 350 - 180 - 0400	205	1754	G 1 1/2

5

Installation, operation and maintenance information

5.1 General notes

These accumulators are subject to the Pressure Equipment Directive PED 97/23/EC.

In accordance with article 3 of the Pressure Equipment Directive 97/23/EC the following hydraulic accumulators require a declaration of conformity as well as a CE mark:

- Hydraulic accumulators with a volume > 1 litre and $p \cdot V > 50$ bar · litre (section 1.1 a, fluids in group 2)
- Hydraulic accumulators with $p \cdot V > 10,000$ bar · litre (section 1.1 b, fluids in group 2)

BetrSichV is the German implementation of the EU directive 2009/104/EC

Only operate the accumulator within the specified data. The accumulator must only be installed, maintained and repaired by authorised and appropriately trained staff ; these tasks are governed by national regulations, the industrial health and safety regulations "Betriebssicherheitsverordnung (BetrSichV)" apply in Germany.

The gas pre-filling must be checked regularly.

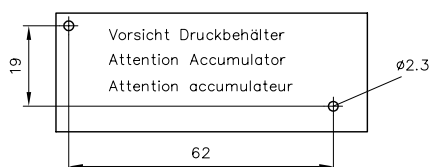

Note

The complete hydraulic system has to be discharged prior to any kind of repair. A respective plate (HAWES order No. 7788 022 (4708 4258-00)) has to be applied at an easily visible spot on or near-by the accumulator.

No modification (welding, soldering, nor mechanical) must be carried out on the accumulator.

Only original spare parts are allowed to be used.

5.1.1 Safety instructions

DIN EN ISO 4413:2010 provides further information on the technical design of accumulator systems. Summarizing there must be a facility to discharge the accumulator fluid side when servicing is carried out (drain valve and pressure gauge for monitoring purposes). The hydraulic accumulator must have its own safety valve (certified valve with TÜV unit approval). This must limit any momentary overpressure to 10% of the highest permissible pressure. In addition, a warning stating "Caution – discharge accumulator prior to removal" must be affixed.

5.1.2 Legal provisions

Hydraulic accumulators are classified as pressure vessels under the European Pressure Equipment Directive 97/23/EC. The local regulation for commissioning and operation for hydraulic accumulators have to be observed. The operator holds sole responsibility for compliance with the existing regulations. The supplied documents must be kept in a safe place, they will be needed for recurring inspections.

5.1.3 Transport and storage



Caution

Danger of injury and material damage due to incorrect transportation!

- Comply with the relevant regulations on transportation and safety.



Note

Accumulators must be stored in a cool, dry place and protected from direct sunlight.

Dirt must be prevented from entering the accumulator.

If the accumulator is stored over a longer period, it is advisable to reduce the gas pre-load pressure to approx. 10 bar to prevent deformation of the sealing element or separator.

5.2 Designated use

This fluid-power product has been designed, manufactured and tested acc. to standards and regulations generally applicable in the European Union and left the plant in a safe and fault-free condition.

To maintain this condition and ensure safe operation, operators must observe the information and warnings in this documentation.

This fluid-power product must be installed and integrated in a hydraulic system by a qualified staff who is familiar with and observes the general engineering principles and relevant applicable regulations and standards.

In addition, application-specific features of the system or installation location must be taken into account if relevant.

This product may only be used as a hydraulic accumulator within oil-hydraulic systems.

The product must be operated within the specified data. This documentation contains the technical parameters for various product versions.



Note

Non-compliance will void any warranty claims made against HAWE Hydraulik.

5.3 Assembly information

The hydraulic accumulator must be integrated in the system via state of the art connection components (screw fittings, hoses, pipes, etc.). The hydraulic system must be shut down as a precautionary measure prior to dismantling; this applies in particular to systems with hydraulic accumulators.

5.3.1 Installation and commissioning

**Warning****Risk of injury due to stored pressure escaping in an uncontrolled manner!**

- Prior to all maintenance work, depressurise the hydraulic system

1. Fit the accumulator to the bracket intended for this purpose, if possible route the gas side directing upwards.
2. Fit the required shut-off, drain and safety valves between the accumulator and the hydraulic system. The easiest way to do this is probably using a 'safety block' that contains all the above cap.

Filling instructions

**Danger****Risk to life due to hydraulic accumulators potentially exploding if they are not filled correctly!**

- Ensure that the accumulator is suitable for the operating conditions in relation to max. operating pressure, filling pressure and temperature range.
- Fill hydraulic accumulators only with N₂ (nitrogen).
- Only use suitable filling and testing devices.

Requirement: The pre-fill/drain valve on the filling device must be closed.

Requirement: The filling device is mounted and connected in accordance with the information from the manufacturer.

1. Check on the pressure gauge on the filling device. Open the valve on the gas bottle valve and fill the accumulator to the required pre-load pressure.
 2. Close the valve on the gas bottle again. The gas pressure stabilises in approx. 1 minute.
 3. If the gas pressure is too low, repeat the procedure.
 4. If the gas pressure is too high, open the pre-fill/drain valve on the filling device.
- ✓ The hydraulic accumulator is filled with gas pressure.

Assembling and mounting example filling device HPCCK

1. Mount the adapter for the gas valve (1), the pressure gauge (6) and the filling hose (7) on the housing (5).
2. Mount the quick connector (9) on the open end of the filling hose (7).
3. Mount the quick connector with the filling hose on the gas valve on the piston type accumulator.
- ✓ The filling device has been fully assembled.
4. The pre-fill/drain valve (8) must be closed. It must be checked.
5. Insert the nylon seal and mount the filling device on the gas cylinder using adapter (1). Use corresponding tools for this purpose.
- ✓ The filling device has been fully mounted on the gas cylinder and is ready for operation.



Figure 2: Filling device type HPCCK suitable for MINIMESS 1620 screw connection with M16 x 2 thread.

1. Adapter for gas valve 24.32 x G 1 1/4 (BSPP)
2. O-ring
3. Adapter G 1/4 (BSPP)
4. Fitting G 1/4 (BSPP)
5. Housing with G 1/4 (BSPP) connections
6. Pressure gauge (0-160 bar)
7. 2.5 m filling hose with M16x2 connector
8. Drain valve
9. Quick connector
10. Double nipple G 1/4 - 1/4 (BSPP)
11. Nylon seal

5.4 Operating instructions

Filtering and purity of the hydraulic fluid

Soiling in the fine range, e.g. abraded material and dust, or in the macro range, e.g. chips, rubber particles from hoses and seals, can cause significant malfunctions in a hydraulic system. It is also to be noted that new hydraulic fluid "from the drum" does not necessarily meet the highest purity requirements.

For trouble-free operation pay attention to the purity of the hydraulic fluid (see also purity class in [Chapter 3, "Parameters"](#)).

5.5 Maintenance information

This product is largely maintenance-free.

Conduct a visual inspection to check the hydraulic connections for damage at regular intervals, but at least once per year. If external leaks are found, shut down and remedy.

Check the device surfaces for dust deposits at regular intervals (but at least annually) and clean the device if required.

5.5.1 Relieving pressure in piston type hydraulic accumulator and removing



Warning

Risk of injury due to stored pressure escaping in an uncontrolled manner!

- Prior to all maintenance work, depressurise the hydraulic system

- The filling device is mounted and connected in accordance with the information from the manufacturer. (See example in chapter: ["Installation and commissioning"](#))
 1. Completely release the gas from the accumulator through the bleed opening by slowly turning the drain valve counter-clockwise.
- The piston type accumulator is now depressurised and can be removed.
- The piston type accumulator is depressurised

When replacing parts: Only use genuine spare parts from the manufacturer!

5.5.2 Installing piston type accumulator

1. Ensure that the internal surface of the cylinder tube and the thread are clean and free of swarf.
2. Install in reverse order to the removal procedure described above, applying a little hydraulic oil to lubricate the seals to make it easier to install the components.

5.5.3 Checking gas filling pressure

1. Fit the gas valve adapter for the gas bottle (1), the pressure gauge (6) and the filling hose (7) to the housing (5) and the quick coupler (9) to the other end of the filling hose (7).
 2. Fit the filling hose (7) with the quick coupler (9) to the gas valve for the piston-type accumulator.
 3. Check that the filling/drain valve (8) is closed (turn clockwise).
 4. Fit the filling device with adapter (1) to the gas bottle. Use tool. Do not forget the nylon seal (11).
 5. Read off the current filling pressure on the pressure gauge (6).
- If the fluid level is too low, continue from step 5 of the filling instructions in [Chapter 5.3.1, "Installation and commissioning"](#).

6 Other information

6.1 Accessories, spare parts and separate components

Charging equipment

Coding

Scope of delivery

Minimes connection

Seal kits (spare part)



Note

For instructions on use and operation, see [Chapter 5.3, "Assembly information"](#)

Charging kit HPCK (8800 8125-00)

Gas-filling valve, pressure gauge, supply line and connector
For the gas bottle adapter see table (**order separately**)

Country	AT, CS, DE, DK, NL, NO, PL, SE	IT	AU, GB, IE, IN, NZ, ZA	CA, US	HU, IL	FR, SU
Coding of adapter	6099 0124-00	6099 0126-00	6099 0127-00	8330 0503-00	6099 0122-00	6099 0123-00

Order coding **3019 5131-00**

Suitable for	Order coding
HPS 10-350-50-...	Seal kit HPS 50
HPS 10-350-80-...	Seal kit HPS 80
HPS 10-350-100-...	Seal kit HPS 100
HPS 10-350-140-...	Seal kit HPS 140
HPS 10-350-160-...	Seal kit HPS 160
HPS 10-350-180-...	Seal kit HPS 180

6.2 Mounting brackets

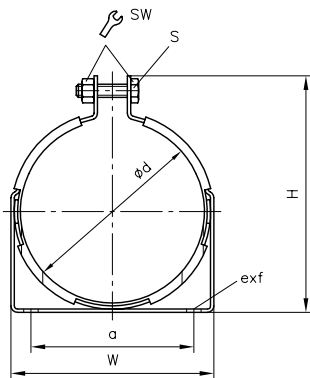
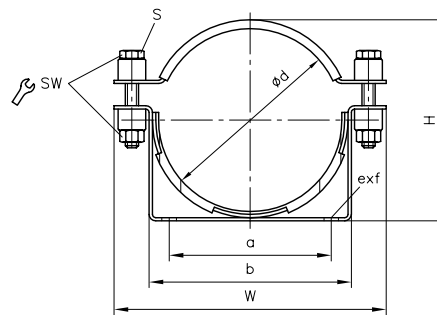
Version 1

Version 2

Coding	Suitable for HPS...	Version	H	W	Width	Material thickness (mm)	$\varnothing d$	a	b	Slot hole exf	S	SW	m (kg)
HP Clamp 60	-050	1	102	80	34	3	60	50	--	9x15	1xM10x30-8.8	17	0.3
HP Clamp 90	--	1	140	110	34	3	90	80	--	9x15	1xM10x30-8.8	17	0.43
HP Clamp 95	-080	1	140	110	34	3	95	80	--	9x15	1xM10x30-8.8	19	0.43
HP Clamp 95-2	-080	2	110	170	34	3	95	68	111	13x21	2xM12x70-8.8	19	0.72
HP clamp 120-2	-100	2	135	202	34	3	120	88	131	13x21	2xM12x70-8.8	19	0.81
HP clamp 120 H-2	-100	2	144	205	34	5	125	88	140	13x21	2xM12x70-8.8	19	1.1
HP clamp 165-2	-140	2	180	235	40	3	165	125	171	13x21	2xM12x70-8.8	19	1.05
HP clamp 185-2	-160	2	200	255	40	3	185	145	191	13x21	2xM12x70-8.8	19	1.13
HP clamp 185 H-2	-160	2	200	270	40	5	185	145	195	13x25	2xM12x70-8.8	19	1.56
HP clamp 205-2	-180	2	220	290	40	3	205	152	211	13x21	2xM12x70-8.8	19	1.25
HP clamp 205 H-2	-180	2	220	295	40	5	205	152	215	13x21	2xM12x70-8.8	19	1.71

6.3 Layout instructions

Max. working pressure

The max. permissible working pressure is the maximum pressure that may be applied to the accumulator. For these accumulators it is 350 bar.

Parameters

- p_0 : gas pre-load pressure
- p_1 : min. operation pressure
- p_2 : max. operation pressure
- V_0 : effective nominal volume of accumulator
- V_1 : gas nominal volume at p_1
- V_2 : gas nominal volume at p_2
- ΔV : delivered or received usable oil volume between p_1 and p_2

Gas pre-load pressure p_0
(reference values)

Depending on application:

- pressure storage: approx. 90% of the minimal working pressure
- pulsation dampening: approx. 60% of the maximum working pressure
- Consideration of temperature influence $p_{0,t_{\min}} = p_{0,t_{\min}} \cdot \frac{t_{\min} + 273}{t_{\max} + 273}$

State change

The compression and decompression of accumulator fillings follow the phys. law of polytropic gas state changes. There are the following thermodynamic condition:

- an isothermal condition change happens during slow changes, e.g. when used to compensate leakage
- The adiabatic change in rapid processes, e.g. for use as a damping element

Calculation V_0

$$V_0 = \frac{\Delta V}{\left(\frac{p_0}{p_1}\right)^{\frac{1}{n}} - \left(\frac{p_0}{p_2}\right)^{\frac{1}{n}}} \quad (\text{reference value: } V_0 = 1.5 \text{ to } 3 \times \Delta V)$$

Basic design

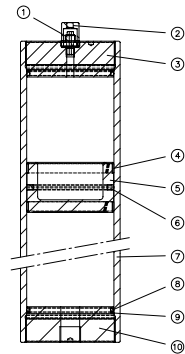

1. Gas valve
2. Valve Protection
3. Gas flange
4. Guide ring
5. Piston
6. Piston seal
7. Cylinder tube
8. Flange seal
9. Back up ring
10. Fluid flange

Additional versions

- Miniature hydraulic accumulators, type AC: D 7571