

Pressure valves type MV.., DMV.. and SV..

Pressure limiting valves, differential pressure regulators

Pressure p_{max} = 700 bar
 Flow Q_{max} = 160 lpm

Additional versions

- Versions as assembly kit see D 7000 E/1
- Versions with component approval (TÜV inspected) see D 7000 TÜV

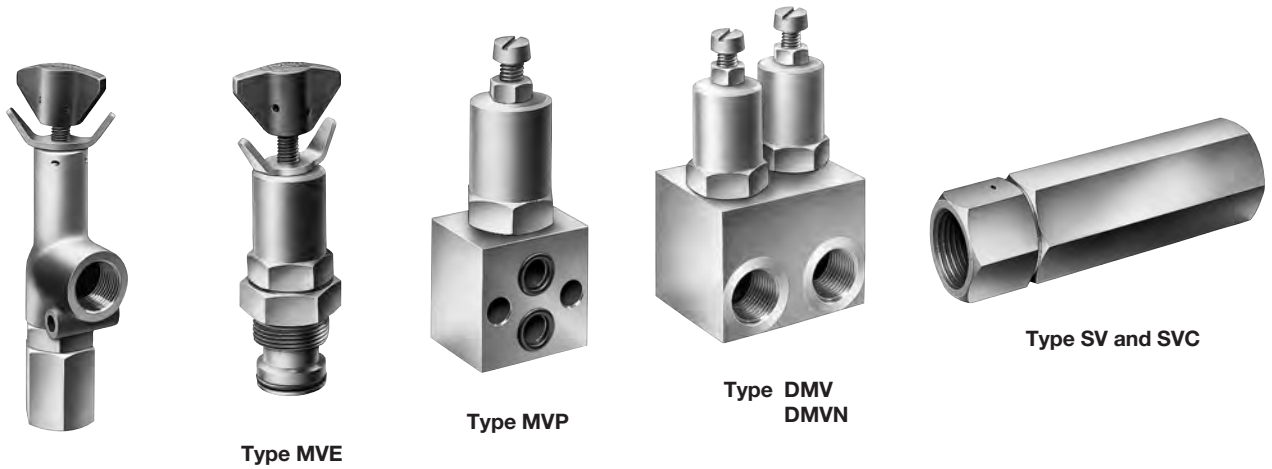

Type MV and MVS
MVC

1. General

Pressure valves primarily influence the pressure in hydraulic installations (DIN ISO 1219-1). The types listed here are to complete following tasks:

The pressure relief valves are not suited for safeguarding pressure devices acc. to Pressure Equipment Directive 97/23/EC. There are also versions available featuring unit approvals, see D 7000 TÜV, D 7710 TÜV, D 6905 TÜV.

• Pressure limiting valve

Protection against exceeding the maximum pressures approved for the system (relief valve) or limiting the working pressures. All valves listed in this leaflet can be used for this purpose.

• Differential pressure regulator

Generation of a constant pressure difference between the inlet and outlet of the flow. Valves with a housing in steel or spheroidal casting can be used for this purpose (see list of types on sect. 3.1).

• Pressure limiting valve without damping

For special operating conditions, e.g. to prevent creeping pressure rises in sealed cylinder chambers during temperature rise or compulsory creeping piston movement because of externally induced forces. Very low difference between opening and reseal pressure.

2. Typical construction

Means of adjustment with adjustable version

(Coding R = Wing screw
 Coding V and H = Turn knob, see section 3.1)

Washer to limit the adjustment distance (see section 5)

Valve housing (spring dome) in zinc die casting, spheroidal casting or in steel for maximum adaption to local installation conditions (inline or manifold mounting, cartridge version)

Stroke limitation prevents the valve ball from being lifted out too far when the spring is completely relieved or when the flow through the valve is too high, also prevents the dampening plunger from blocking the flow passage.

Dynamically acting lift aid results in a pressure setting, which is rather flow independent (constant pressure characteristics)

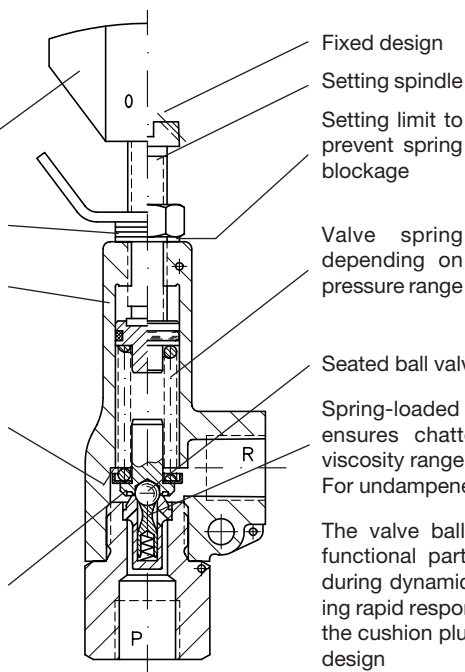

Lead seal provision (Lead sealing is available from HAWE when added in uncoded text to your order)

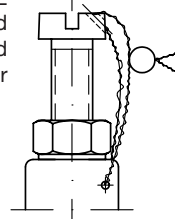

Seated ball valve insensitive to contamination

Spring-loaded dampening plunger with a long guide ensures chatter free operation throughout a wide viscosity range
 For undampened valves, see section 1.

The valve ball and dampening plunger are separate functional parts, which do not obstruct one another during dynamic stress (pressure peaks), thereby ensuring rapid response of the ball upon sudden pressure rise, the cushion plunger is missing in the undampened valve design

3. Types available

3.1 Type code and main data

Order examples:

MVP 4 A - 650
MV 53 B R X
DMV 4 B/C - 300/200 Desired pressure setting (bar) (without specification, see table 2)

X = Undamped version acc. to sect. 1

Table 1: Basic type and Size

Brief description	Connection size and thread		Spring dome material		
	Basic type Size	ISO 228/1 (BSPP)			
Pressure limiting valve	Corner valve for pipe mounting (tapped ports P and R)	41	G 1/4	Zinc die casting	
		42	G 3/8		
		52	G 3/8		
		53	G 1/2		
		63	G 1/2		
		64	G 3/4		
Pressure limiting valve and sequence valves	Corner valve for pipe mounting (tapped ports P and R)	41	G 1/4	Spheroidal casting	
		42	G 3/8		
		52	G 3/8		
		53	G 1/2		
		63	G 1/2		
		64	G 3/4		
	Screw-in valve (for manifold mounting)	MVE	4	Stepped bore, see dimension. drawing	Steel:
			5		
			6		
			8		
Valve for (manifold mounting)	MVP	4	Manifold, see dimensional drawing	Steel: Perm. pressure P = 700 (400) bar R = 350 bar	
		5			
		6			
		8			
For inline installation in a pipe system (tapped hole at P and R)	SV	42	G 3/8	Steel: Perm. pressure P = 700 (400) bar R = 500 (400) bar	
		53	G 1/2		
		64	G 3/4		
		85	G 1		
Pressure limiting valve (as shock valve), pipe mounting	Double valve for hydraulic motor (tapped hole at P and R)	41	G 1/4	Steel: Perm. pressure P and R = 350 bar	
		42	G 3/8		
		52	G 3/8		
		53	G 1/2		
		63	G 1/2		
		64	G 3/4		
		84	G 3/4		
		85	G 1		
Pressure limiting valve with suction valve for cylinders, (tapped hole at A, B, R)	DMVN	42	G 3/8	Steel: Perm. pressure A, B = 350 bar R = 20 bar	
		53	G 1/2		
		64	G 3/4		
Single valve with thru-holes (tapped hole at P and R)	MVT	63	G 1/2	Steel: Perm. pressure P and R = 315 bar	
		1) 3) 5)			
Pressure limiting valve with free return R → P via a by-pass check valve	Corner valve, pipe mounting	46	G 3/8	Spheroidal casting	
		56	G 1/2		
		66	G 3/4		
		47	G 3/8 (A)		Perm. pressure P and R = 500 bar
		58	G 1/2 (A)		
	For inline installation in a pipe system	SVC	46	G 3/8	Steel: Perm. pressure P and R = 500 bar
			56	G 1/2	
			66	G 3/4	
			47	G 3/8 (A)	
			58	G 1/2 (A)	
69	G 3/4 (A)				

Table 3: Adjustment (during operation)

Without coding	Standard, tool adjustable
R	Manually adjustable (Wing screw+wing nut)
V 5) 8)	Turn knob (self-locking)
H 5) 10)	Turn knob lockable Keys conforming the regulations of the automotive industry; One key is scope of delivery (usually anyway in the possession of the authorized work staff)

Table 2: Pressure range and flow

Attention: The pressure will be set acc. to the table below, if not ordered otherwise

Pressure range	A 3)	B	C	E	F
(0) 4) ...	700	500	315	160	80
... P _{max} (bar)	Size 4, 5, 6				
	Size 8	700	400 9)	315	160
Pressure setting from HAWE (bar) 2)	450	400	315	160	80
Corresponding flow	Size 4	12	20		
	Size 5	20	40		
Q _{max} (lpm)	Size 6	40	75		
	Size 8	100	160		

Symbols

Illustration of the standard version (tool adjustable)

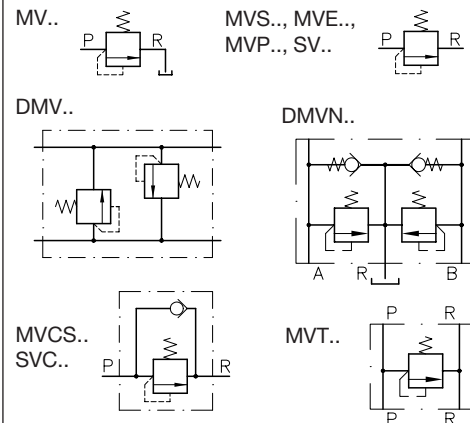

Additional adjustability:

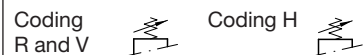

- 1) Tool adjustable version only
- 2) When not specified in the order
- 3) Pressure range coding A not avail. for type DMV, DMVN, MVT, MVCS, and SVC
- 4) A setting below 0.2 P_{max} is not effective. The min. pressure that can be achieved, when the spring is completely decompressed depends on the valve related back pressure and the flow (sect. 3.2)
- 5) Not available as size 8
- 6) Suction valves serve for the volume compensation, preventing the formation of a vacuum within hydraulic cylinders
- 8) Coding V not available for type MVS 4
- 9) Pressure range B not available for type SV 85
- 10) Coding H not available for type MVE 4 and MVP 4

3.2 Additional data

Nomenclature and design	Pressure valve controlled directly, ball seated design																																																							
Intended application	Zinc die-casting: Standard model for normal production conditions Spheroidal casting: For rough operation conditions; where mechanical shocks or vibrations cannot be avoided (automotive engineering). Also when there are pressure surges in the return pipe.																																																							
Mounting and installed position	Dep. on type, either freely suspended in the pipe work, secured via a thru-hole or screw-in or manifold mounting; arbitrary installation position																																																							
Line connection	Steel or spheroidal cast parts zinc galvanized; Spring domes made of zinc pressure die-casting are untreated																																																							
Flow direction	P → R, with SVC and MVCS free return flow R → P (Attention: Observe Q_{max} sect. 3.1, table 2)																																																							
Mass (weight) approx. kg	<table border="1"> <thead> <tr> <th>Size</th> <th>MV</th> <th>MVS</th> <th>MVE</th> <th>MVP</th> <th>SV</th> <th>DMV</th> <th>DMVN</th> <th>MVT</th> <th>MVCS</th> <th>SVC</th> </tr> </thead> <tbody> <tr> <td>4</td> <td>0.2</td> <td>0.2</td> <td>0.2</td> <td>0.3</td> <td>0.2</td> <td>0.7</td> <td>0.8</td> <td>---</td> <td>0.3</td> <td>0.3</td> </tr> <tr> <td>5</td> <td>0.3</td> <td>0.3</td> <td>0.3</td> <td>0.5</td> <td>0.3</td> <td>1.3</td> <td>1.5</td> <td>---</td> <td>0.4</td> <td>0.4</td> </tr> <tr> <td>6</td> <td>0.5</td> <td>0.5</td> <td>0.4</td> <td>0.8</td> <td>0.7</td> <td>1.8</td> <td>2.4</td> <td>1.3</td> <td>0.7</td> <td>0.9</td> </tr> <tr> <td>8</td> <td>---</td> <td>2.0</td> <td>1.0</td> <td>1.6</td> <td>0.9</td> <td>4.5</td> <td>---</td> <td>---</td> <td>---</td> <td>---</td> </tr> </tbody> </table>	Size	MV	MVS	MVE	MVP	SV	DMV	DMVN	MVT	MVCS	SVC	4	0.2	0.2	0.2	0.3	0.2	0.7	0.8	---	0.3	0.3	5	0.3	0.3	0.3	0.5	0.3	1.3	1.5	---	0.4	0.4	6	0.5	0.5	0.4	0.8	0.7	1.8	2.4	1.3	0.7	0.9	8	---	2.0	1.0	1.6	0.9	4.5	---	---	---	---
Size	MV	MVS	MVE	MVP	SV	DMV	DMVN	MVT	MVCS	SVC																																														
4	0.2	0.2	0.2	0.3	0.2	0.7	0.8	---	0.3	0.3																																														
5	0.3	0.3	0.3	0.5	0.3	1.3	1.5	---	0.4	0.4																																														
6	0.5	0.5	0.4	0.8	0.7	1.8	2.4	1.3	0.7	0.9																																														
8	---	2.0	1.0	1.6	0.9	4.5	---	---	---	---																																														
Pressure fluid	Hydraulic oil conforming DIN 51524 part 1 to 3: ISO VG 10 to 68 conforming DIN 51519. Viscosity limits: min. approx. 4, max. approx. 1500 mm ² /s, opt. operation approx. 10... 500 mm ² /s. Also suitable for biological degradable pressure fluids types HEPG (Polyalkylenglycol) and HEES (Synth. Ester) at service temperatures up to approx. +70°C.																																																							
Temperature	Ambient: approx. -40 ... +80°C Fluid: -25 ... +80°C; Note the viscosity range ! Permissible temperature during start: -40°C (Note start-viscosity!), as long as the service temperature is at least 20K higher for the following operation. Biological degradable pressure fluids: Note manufacturer's specifications. By consideration of the compatibility with seal material not over +70°C.																																																							
Δp-Q-characteristics	Characteristic curve shown with example MV..C (basic tendency, there are certain differences depending on the pressure range and the housing shape of the various basic types) An increased return back pressure will transform the curves into positive Δp-figures.																																																							

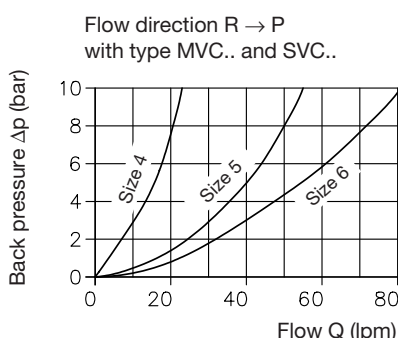
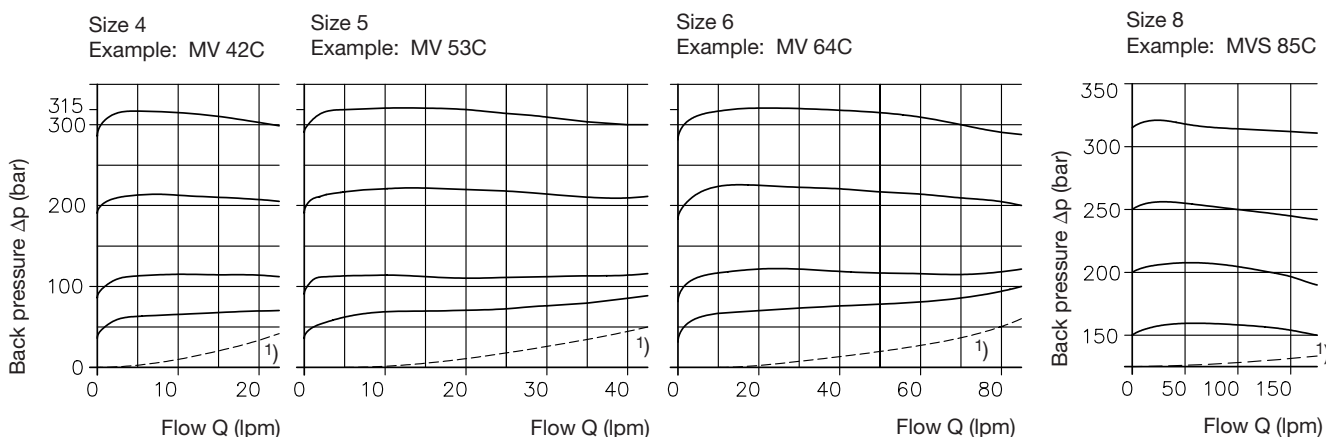

Oil viscosity during testing 50 mm²/s

Pressure variations (apply to all valves acc. to sect. 3.1). Rough guide line figures (valve idling) per one turn of the set screw.

Pressure range (bar)	Travel f_{max} (mm) / Δp (bar) per one turn ²⁾			
	Size 4	Size 5	Size 6	Size 8
A 0 ... 700	4.5 / 195 (4.3 / 220)	8.4 / 105 (9.1 / 140)	7.4 / 120 (7 / 180)	---
B 0 ... 500 (400)	6.3 / 100 (6.1 / 110)	9.7 / 65 (10 / 90)	7.9 / 80 (7 / 130)	9 / 68
C 0 ... 315	7.1 / 55 (6.5 / 65)	7.7 / 51 (7.2 / 80)	10.2 / 35 (9.3 / 62)	13 / 37 (12.8 / 57)
E 0 ... 160	10.5 / 19 (8 / 27)	12 / 17 (11.2 / 26)	11.5 / 17.5 (10 / 29)	12.5 / 20 (12.4 / 30)
F 0 ... 80	10.5 / 9.5 (7.2 / 15)	11.5 / 9 (7.3 / 20)	12.5 / 8 (9.7 / 15)	---

Attention: Any pressure re-adjustment should be monitored with a pressure gauge! For adjustment instruction, see section 5

1) Design related characteristic back pressure with spring relieved (static pressure value 0 bar). Pressure below this limit line cannot be achieved, see also footnote 4), sect. 3.1

2) Figures in brackets apply to type SV and SVC

4. Dimensions of units

All dimensions are in mm, subject to change without notice!

Type MV 4(5, 6) and MVS 4(5, 6)

Means of adjustment coding R

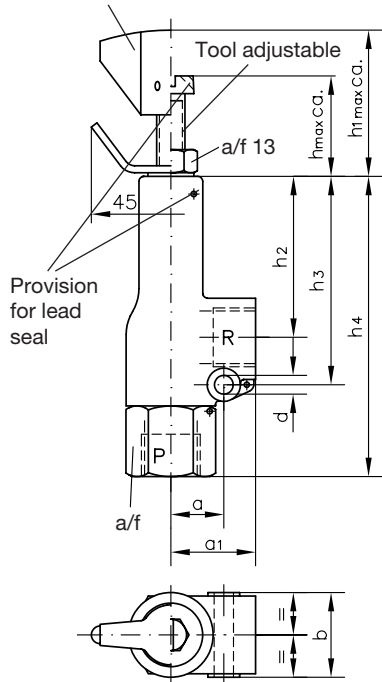

Means of adjustment coding V

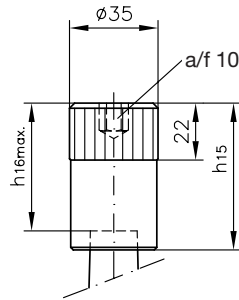

Means of adjustment coding H

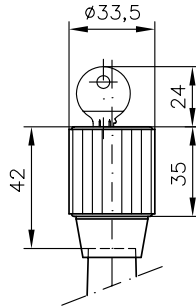

Type MVCS 4(5, 6)

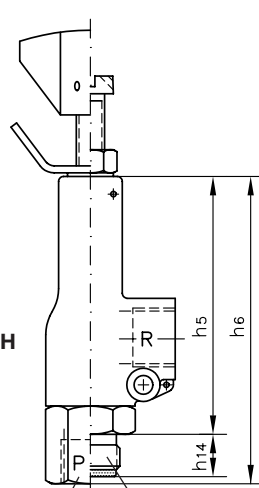

MVCS..6 MVCS..7(8, 9)

Tapped holes shap X Tapped journal shape B

similar to DIN 3852 page 2

Type MVS 8

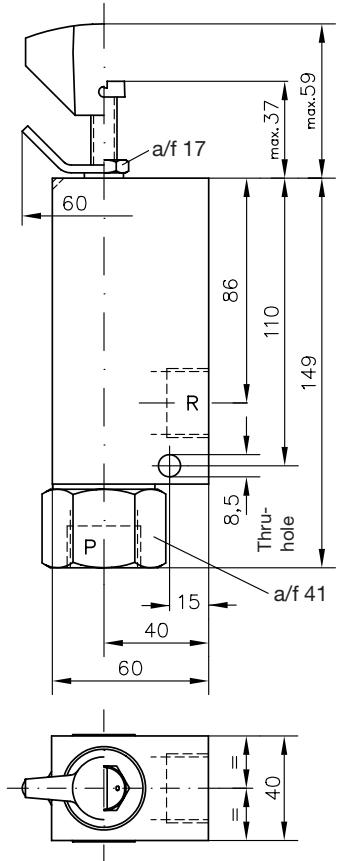

Size	a	a ₁	b	d	h	h ₁	h ₂	h ₃	h ₄	h ₅	h ₆	h ₁₄	h ₁₅	h ₁₆	a/f
4	15	24	24	5.3	28	40	46	61	86	72	85.5	13	58	41	22
5	18	30	29	6.4	31	42	49	66	95	82	100.5	15	58	41	27
6	20	35	36	6.4	31	44	62	82	117	100	120	17	64	56	30

For port size, see section 3.1

Type MVE 4(5, 6, 8)

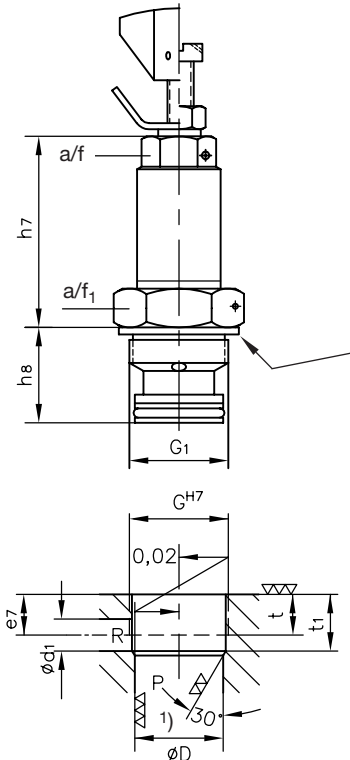

1) at pressure below 315 bar there is also a rougher surface ∇ ($R_e = 1.6$; $R_t = 16$) permissible

Size	Sealing ring DIN 7603...
4	A 22x27x1.5 (St)
5	A 28x34x2 (St)
6	A 30x36x2 (St)
8	A 40x49x2 (St)

Size	Thread G and G1
4	M22x1.5
5	M28x1.5
6	M30x1.5
8	M40x1.5

Type MVP 4(5, 6, 8)

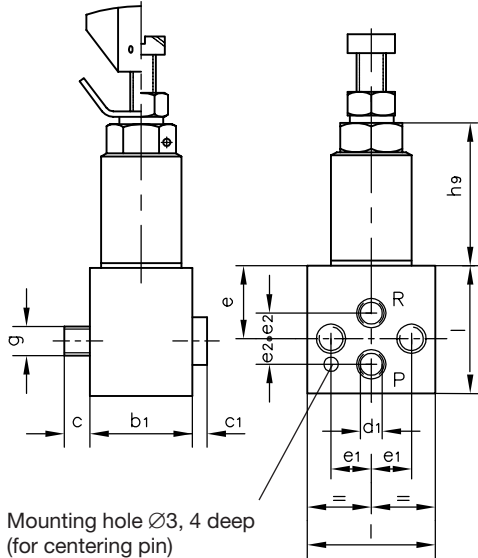

Mounting hole $\phi 3, 4$ deep (for centering pin)

Sealing of ports P and R:

Size	4	5	6	8, 8 A
O-ring NBR 90 Sh	8x2	10x2	13.95x2.62	18.76x2.62

Type MVP 8 A

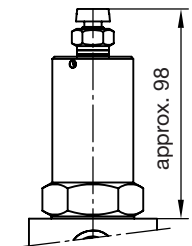

Size	h ₇	h ₈	D	e ₇	d ₁	t	t ₁	a/f	a/f ₁	Torque for steel (Nm)	Size	b ₁	c	c ₁	d ₁	e	e ₁	e ₂	g	h ₉	l
4	48	26	18 ^{H8}	12	6	12	15	22	27	80	4	28	7	8	6	20	11	7	M8	39	35
5	53.5	27	25 ^{H8}	11.5	9	9	16	27	32	120	5	32	8	8	9	21	13.5	9	M8	42	40
6	65.5	32	25 ^{H8}	14	12	10	19	30	36	160	6	35	10	10	12	26	17	11	M10	51.5	50
8	90	40	36 ^{H8}	19	16	12	27	41	46	300	8, 8 A	50	15	12	16	30	20	13	M12	75	60

Type DMV 4(5, 6, 8)

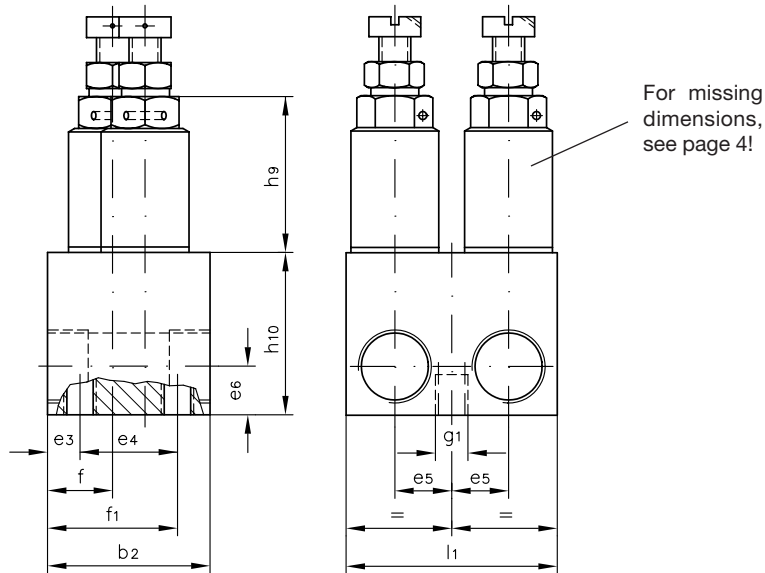

Size	b ₂	e ₃	e ₄	e ₅	e ₆	f	f ₁	g ₁	h ₉	h ₁₀	l ₁
4	40	8	24	14	12	16	24	M 8, 10 deep	39	40	52
5	50	10	30	18	15	19	31	M 8, 10 deep	42	50	65
6	60	10	40	21	18	23	37	M 10, 12 deep	51.5	60	75
8	80	10	60	27	25	30.5	49.5	M 10, 12 deep	75	80	96

For port size, see section 3.1

Type SV 4(5, 6, 8)

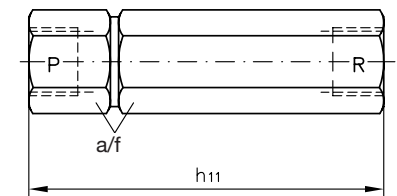

Type SVC 4(5, 6)

SVC..6: Tapped holes 1) form X

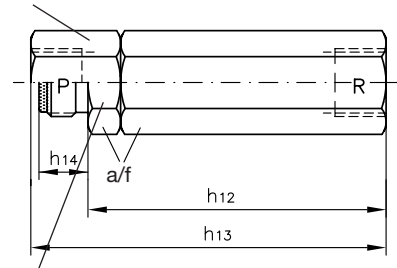

SVC..7(8, 9): Threaded stem 1) form B

Size	h ₁₁	h ₁₂	h ₁₃	h ₁₄	a/f
4	87	73	87	13	22
5	104	90	109	15	27
6	129	112	132	17	32
8	157	---	---	---	41

For port size, see section 3.1

1) similar to DIN 3852 page 2

Type DMVN 42(53, 64)

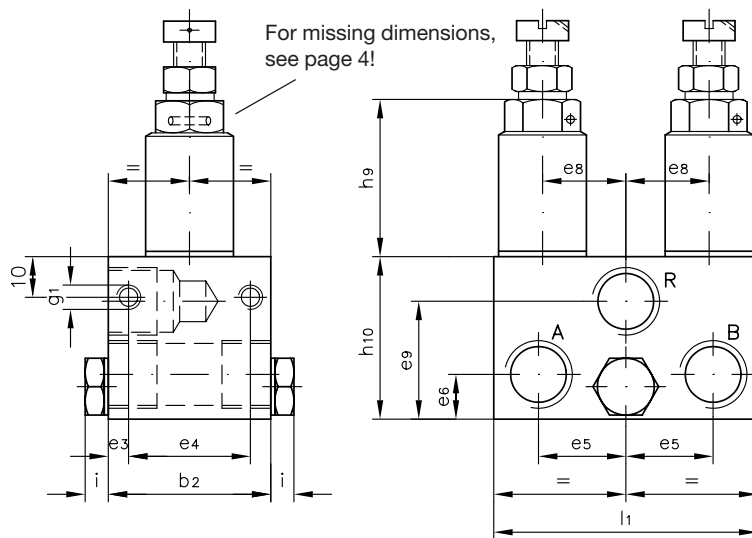

Size	b ₂	e ₃	e ₄	e ₅	e ₆	e ₈	e ₉	g ₁	h ₉	h ₁₀	i	l ₁
4	40	5	30	21.5	11	20.5	29	M6, 10 deep	39	40	9	65
5	50	7.5	35	27	14	26.5	36	M8, 12 deep	42	50	9	82
6	60	9	42	32	16.5	32	44	M10, 12 deep	51.5	60	5	97

For port size, see section 3.1

Type MVT 63

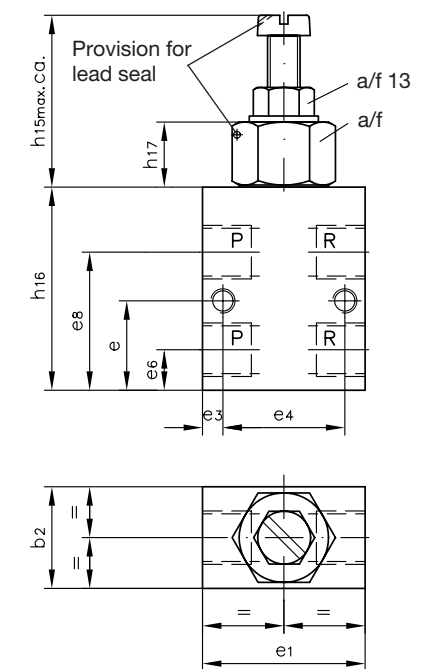

Size	b ₂	e	e ₁	e ₃	e ₄	e ₆	e ₈	h ₁₅	h ₁₆	h ₁₇	a/f
6	35	32	50	7	36	14	50	52	70	27	30

For port size, see section 3.1

5. Adjustment instruction

The valves are delivered with proper setting from HAWE, when specified in your order (e.g. MV 53C - 250 bar). Washers prevent unauthorized increasing of the set pressure at adjustable valves. The pressure will be set acc. to they table 2 in sect. 3.1, if not ordered otherwise. Any pressure adjustment should be monitored by a pressure gauge and while the pump is running.

● Reduction of the setting

1. Pressure gauge connected to the pressure pipe (pressure gallery)
2. Type MV... and DMV(N): Loosen the lock nut (remove lead seal if necessary)
Type SV(C): Loosen grub screw
3. Turn the adjustment device counter clockwise (monitored by a pressure gauge)
4. Tighten the lock nut / grub screw after finished procedure. Renew the lead seal if required

● Raising of the setting

Observe the p_{max} figures stated in section 3.1 !

In principle proceed as above. Pressure increase when turned clockwise. Washers usually prevent unauthorized increasing of the pressure with manually adjustable versions. It is therefore necessary to remove enough of them (after driving the rollpin out of the winged handle) before the increased pressure can be set. Again any pressure adjustment should be monitored by a pressure gauge. After finishing the setting procedure sufficient washers, the winged locknut, the winged handle and the rollpin must be reinstalled.

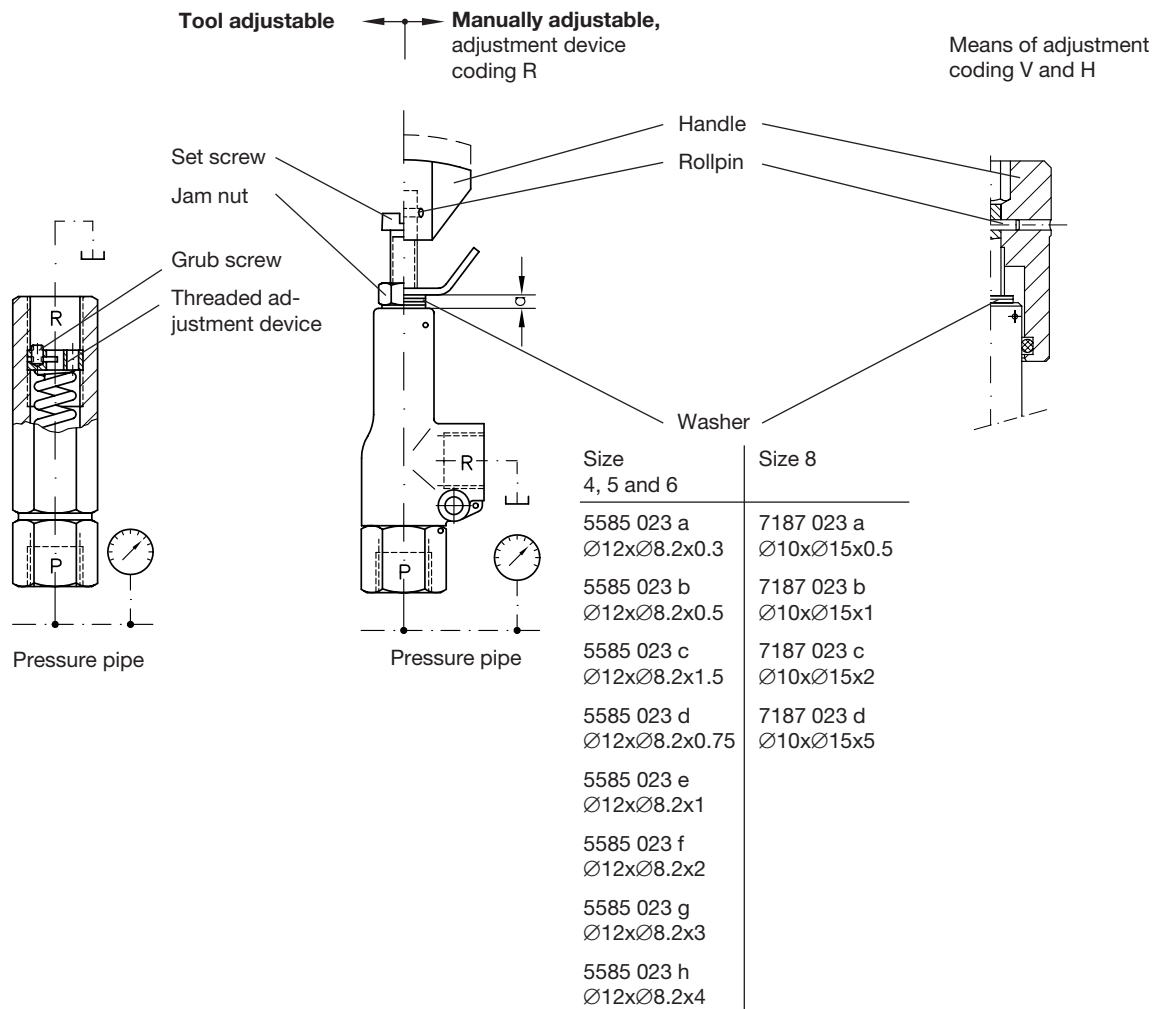

Note: The pressure reading on the dial during adjustment, while the pump is running is always corresponding to this flow. Flow deviations will cause a slightly differing response pressure, depending on the design related back pressure of the valve housing (see sect. 3.2). Please add to your order coding in uncoded text „set at start of response“ when required e.g. for a pressure limiting valve intended for a hand pump $Q \approx 0$ lpm.