

Check valve type RK and RB

Product documentation



Screw-in valve

Operating pressure p_{\max} : 700 bar

Flow rate Q_{\max} : 400 lpm



© by HAWE Hydraulik SE.

The forwarding and reproduction of this document, as well as the use and communication of its contents, are forbidden unless expressly permitted.

Any breach or infringement will result in liability for damages.

All rights reserved concerning patent or utility model application.

Contents

1	Overview of check valves type RK and RB.....	4
2	Available versions, main data.....	5
3	Parameters.....	9
3.1	General.....	9
4	Dimensions.....	11
4.1	Creating the mounting hole.....	15
5	Installation, operation and maintenance information.....	18
5.1	Designated use.....	18
5.2	Assembly information.....	18
5.2.1	Screw-in cartridge.....	18
5.2.2	Creating the mounting hole.....	18
5.2.3	Assembly tool for type RK.....	19
5.3	Operating instructions.....	19
5.4	Maintenance information.....	19

Check valves are a type of non-return valve. They block the oil flow in one direction and open in the opposite direction. In the closed state they have zero leakage.

The check valve type RK and RB can be screwed in. The spring-loaded ball check valve type RK and RB is very robust and insensitive to soiling.

Features and benefits:

- Operating pressures up to 700 bar
- Easily machined mounting holes
- Sturdy

Intended applications:

- General hydraulic systems
- Hydraulic pre-loading



Figure 1: Screw-in cartridge

2 Available versions, main data

Circuit symbol:

Type RK

screwed in locking direction



Type RB

screwed in free flow direction



Section view:

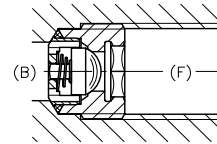
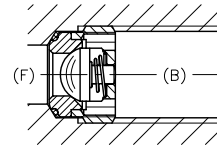

Order coding example:

RB 2	
RK 2-5	-G

Version Table 2 Version

Basic type and size Table 1 Basic type and size

Table 1a Basic type and size type RK

Basic type and size	Volumetric flow Q (lpm)	Pressure p _{max} (bar)	Thread	Opening pressure (bar)
RK 08 RK 08-0.45	5	700	M 8x1	0.2 0.45
RK 08 UNF	5	700	5/16-24 UNF	0.2
RK 0 RK 0-0.4	10	700	G 1/8 A	0.05 0.4
RK 0 UNF	10	700	7/16-20 UNF	0.05
RK 1 RK 1-...	20	700	G 1/4 A	0.18 0.5, 1, 2, 3, 4, 5, 6, 7, 8, 10
RK 14 RK 14-...	20	700	M 14x1.5	0.18 0.5, 1, 2, 3, 4, 5, 6, 7, 8
RK 16	20	700	M 16x1.5	0.18
RK 1 UNF	20	700	9/16-18 UNF	0.18
RK 2 RK 2-...	50	700	G 3/8 A	0.2 1, 2, 3, 4, 5, 6
RK 28 RK 28-...	50	700	M 18x1.5	0.2 1, 2, 3, 4, 5, 6
RK 2 UNF	50	700	3/4-16 UNF	0.2
RK 3 RK 3-...	80	500	G 1/2 A	0.25 1, 2, 3, 4, 5
RK 32 RK 32-...	80	500	M 22x1.5	0.25 1, 2, 3, 4, 5
RK 3 UNF	80	500	7/8-14 UNF	0.25
RK 4 RK 4-...	120	500	G 3/4 A	0.1 0.5, 1, 2, 3, 4, 5, 6, 7, 8, 9, 10
RK 47 RK 47-...	120	500	M 27x2	0.1 0.5, 1, 2, 3, 4, 5, 6, 7, 8, 9, 10
RK 4 UN	120	500	1 1/16-12 UN	0.1
RK 5	240	500	G 1 A	0.1
RK 6 RK 6-...	400 400	420 420	G 1 1/4 A	0.1 0.5, 1, 2, 3, 4, 5, 6, 7, 8, 9, 10
RK 62 RK 62-...	400 400	420 420	M 42x2	0.1 0.5, 1, 2, 3, 4, 5, 6, 7, 8, 9, 10
RK 7	620	420	G 1 1/2 A	0.1

Note

- Thread in accordance with ISO 228/1, DIN 13 T6 (metric) or SAE J 514 (UNF).
- For types RK-... one of the opening pressures provided must be specified, e.g. RK3-5.

Table 1b Basic type and size type RB

Basic type and size	Volumetric flow Q (lpm)	Pressure p_{max} (bar)	Thread	Opening pressure (bar)
RB 08	5	700	M 8x1	0.2
RB 08-0.45				0.45
RB 0.8 UNF	5	700	5/16-24 UNF	0.2
RB 0	10	700	G 1/8 A	0.05
RB 0 UNF	10	700	7/16-20 UNF	0.05
RB 1	20	700	G 1/4 A	0.15
RB 1-1				0.9
RB 14	20	700	M 14x1.5	0.15
RB 1 UNF	20	700	9/16-18 UNF	0.15
RB 2	50	700	G 3/8 A	0.07
RB 28	50	700	M 18x1.5	0.07
RB 2 UNF	50	700	3/4-16 UNF	0.07
RB 3	80	500	G 1/2 A	0.17
RB 32	80	500	M 22x1.5	0.17
RB 3 UNF	80	500	7/8-14 UNF	0.17
RB 4	120	500	G 3/4 A	0.10
RB 47	120	500	M 27x2	0.10
RB 4 UN	120	500	1 1/16-12 UN	0.10

Note

Thread in accordance with ISO 228/1, DIN 13 T6 (metric) or SAE J 514 (UNF).

Table 2 Versions

Model	Description	View	Circuit symbol
No designation	Screw-in cartridge		
RK.. -G RK.. -G-JIS	Pipe connection on both sides		
RB.. -G RB.. -G-JIS			
RK.. -E RK.. -E-JIS	Tapped journal on one side		
RB.. -F			

Note

Thread in accordance with ISO 228/1, SAE J 514 (-UNF) or JIS B 2351(0), (-JIS).

Type	Housing version			
	G	G-JIS	E	E-JIS
RK 08				
RK 08-0.45				
RK 08 UNF				
RK 0	●		●	
RK 0-0,4	●		●	
RK 0 UNF	●		●	
RK 1	●	●	●	●
RK 1-...	●	●	●	●
RK 14	●		●	
RK 14-...	●		●	
RK 16	●		●	
RK 1 UNF	●		●	
RK 2	●	●	●	●
RK 2-...	●	●	●	●
RK 28	●		●	
RK 28-...	●		●	
RK 2 UNF	●		●	
RK 3	●	●	●	●
RK 3-...	●	●	●	●
RK 32	●		●	
RK 32-...	●		●	
RK 3 UNF	●		●	
RK 4	●	●	●	●
RK 4-...	●	●	●	●
RK 47				
RK 47-...	●		●	
RK 4 UN	●		●	
RK 5	●		●	
RK 6	●		●	
RK 6-...	●		●	
RK 62	●		●	
RK 62-...	●		●	
RK 7	●		●	

Type	Housing version	
	G	F
RB 08		
RB 08-0.45		
RB 08 UNF		
RB 0	●	●
RB 0 UNF	●	●
RB 1	●	●
RB 1-1	●	●
RB 14	●	●
RB 1 UNF	●	●
RB 2	●	●
RB 28	●	●
RB 2 UNF	●	●
RB 3	●	●
RB 32	●	●
RB 3 UNF	●	●
RB 4	●	●
RB 47		●
RB 4 UN	●	●

3 Parameters

3.1 General

Designation	Check valves
Design	Ball seated valve
Model	Screw-in cartridge, housing version
Material	Steel; hardened, ground functional inner parts
Installation position	As desired
Surface	Single valves blank, housing version ZnNi
Hydraulic fluid	Hydraulic oil conforming DIN 51 524 part 1 to 3; ISO VG 10 to 68 conforming DIN 51 519 Viscosity limits: min. approx. 4, max. approx. 1500 mm ² /s opt. operation approx. 10... 500 mm ² /s. Also suitable are biologically degradable pressure fluids types HEPG (Poly-alkylenglycol) and HEES (Synth. Ester) at service temperatures up to approx. +70°C.
cleanliness level	ISO 4406 21/18/15...19/17/13
Temperatures	Ambient: approx. -40 ... +80°C, Fluid: -25 ... +80°C, Note the viscosity range! Permissible temperature during start: -40°C (observe start-viscosity!), as long as the service temperature is at least 20K higher for the following operation. Biologically degradable pressure fluids: Observe manufacturer's specifications. By consideration of the compatibility with seal material not over +70°C.

Characteristic curves

Oil viscosity approx. 50 mm²/s

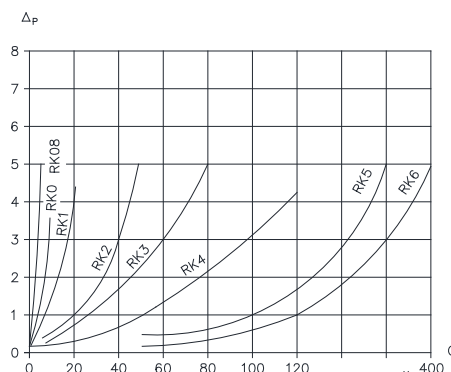

Figure 2: Q volumetric flow (lpm); Δp flow resistance (bar)

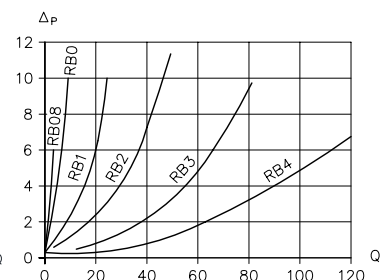

Figure 3: Q volumetric flow (lpm); Δp flow resistance (bar)

Weight

Screw-in cartridge

Type RK 0, RK 08	= 3 g
Type RK 1, RK 14, RK 16	= 5 g
Type RK 1-...	= 30 g
Type RK 2, RK 28	= 12 g
Type RK 2-...	= 40 g
Type RK 3, RK 32	= 20 g
Type RK 3-...	= 60 g
Type RK 4, RK 47	= 45 g
Type RK 5	= 85 g
Type RK 6, RK 62	= 200 g
Type RK 6-..., RK 62-...	= 300 g
Type RK 7	= 280 g
Type RB 0	= 3 g
Type RB 1, RB 14	= 5 g
Type RB 2, RB 28	= 12 g
Type RB 3, RB 32	= 21 g
Type RB 4, RB 47	= 45 g

Housing version

Type and size	G	E	F
RK 0, RB 0	30 g	30 g	30 g
RK 1, RB 1	75 g	60 g	60 g
RK 2, RB 2	105 g	85 g	85 g
RK 3, RB 3	160 g	140 g	140 g
RK 4, RB 4	340 g	300 g	300 g
RK 5	770 g	650 g	--
RK 6	1000 g	950 g	--
RK 7	1650 g	1400 g	--

4 Dimensions

All dimensions in mm, subject to change.

Screw-in cartridge

Type RK ...

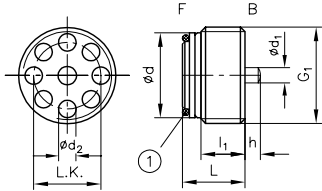

1 O-ring

Type	G ₁	L	l ₁	Ød	Ød ₁	Ød ₂	h	L.K.	Sealing ring NBR 90 Sh	Max. tightening torque M _A (Nm)
RK 08	M 8x1	5.5	--	6.9	--	1.3	--	4.8	5x0.8 (70 Sh)	6
RK 08 UNF	5/16-24 UNF	5.5	3.5	6.7	1.4	1.3	0.8	4.8	5x0.8 (70 Sh)	6
RK 0 RK 0-...	G 1/8 A	7.2	3.8	8.6	2	1.5	1.3	6.8	6x1	8
RK 0 UNF	7/16-20 UNF	7.3	3.8	8.6	2	1.5	1.3	6.8	6x1	8
RK 1 RK 14	G 1/4 A M 14x1.5	9	4.5	11.5	2.6	2.2	1.5	8.8 _{0.1}	9x1	15
RK 1-... RK 14-...	G 1/4 A M 14x1.5	16	7.5	11.45	--	1.8	--	9 _{0.1}	9x1	--
RK 16	M 16x1.5	9	6	14	2.6	2.8	1.5	11	10x1.5	--
RK 1 UNF	9/16-18 UNF	9	4.5	11.5	2.6	2.2	1.5	8.8 _{0.1}	10x1.5	15
RK 2 RK 28	G 3/8 A M 18x1.5	11.2	6.5	15	3.4	3	2.5	11	11x1.5	20
RK 2-... RK 28-...	G 3/8 A M 18x1.5	20	12.5	15	--	2	--	12.1	11x1.5	--
RK 2 UNF	3/4-16 UNF	11.5	6,.	15	3.4	3	2.5	11	11x1.5	20
RK 3 RK 32	G 1/2 A M 22x1.5	13.5	8	18.5	4.3	3.8	3	14.2 _{0.1}	14x1.5	40
RK 3-... RK 32-...	G 1/2 A M 22x1.5	24	15.5	18.7	--	2.9	--	15 _{0.1}	14x1.5	--
RK 3 UNF	7/8-14 UNF	13.5	8	18.5	4.3	3.8	3	14.2 _{0.1}	14x1.5	40
RK 4 RK 47	G 3/4 A M 27x2	17.5	10	24	5.8	4.6	3.5	18.5	18.77x1.78	80
RK 4-... RK 47-...	G 3/4 A M 27x2	30	14.4	24	--	3.5	--	19	18.77x1.78	80
RK 4 UN	1 1/16-12 UN	17.5	10	24	5.8	4.6	3.5	18.5	18.77x1.78	80
RK 5	G 1 A	22	12.5	30	7	4.5	4.5	23	23.47x2.62	150
RK 6 RK 62	G 1 1/4 A M 42x2	27.5	16.5	38.8	8.2	5.8	5	30	29.75x3.53	250
RK 6-... RK 62-...	G 1 1/4 A M 42x2	55	24	38.8	--	5.5	--	30.5	29.75x3.53	250
RK 7	G 1 1/2 A	35	20	44.5	10	6.8	5.5	35.5	36.00x3.00	300

Type RB ...

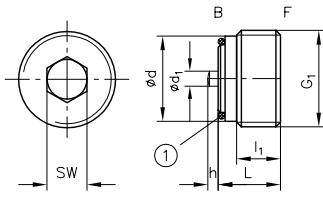

1 O-ring

Type	G ₁	L	l ₁	Ød	Ød ₁	h	SW	Sealing ring NBR 90 Sh	Max. tightening torque M _A (Nm)
RB 08	M 8x1	6.5	--	6.9	--	--	4	5x0.8 (70 Sh)	6
RB 08 UNF	5/16-24 UNF	6.5	3.5	6.7	1.4	0.8	4	5x0.8 (70 Sh)	6
RB 0	G 1/8 A	7.9	4.5	8.6	1.7	1.3	5	6x1	8
RB 0 UNF	7/16-20 UNF	7.9	4.5	9.4	1.7	1.3	5	6x1	8
RB 1 RB 1-1 RB 14	G 1/4 A G 1/4 A M 14x1.5	10.3	5	11.6	2.2	1.3	7	9x1	15
RB 1 UNF	9/16-18 UNF	10.3	5	12.3	2.2	1.3	7	9x1	15
RB 2 RB 28	G 3/8 A M 18x1.5	11.7	7	15	3	2	6	11x1.5	20
RB 2 UNF	3/4-16 UNF	11.7	7	16.8	3	2	6	11x1.5	20
RB 3 RB 32	G 1/2 A M 22x1.5	13.2	7.5	18.5	3.4	2.5	8	14x1.5	40
RB 3 UNF	7/8-14 UNF	13.2	7.5	19.9	3.4	2.5	8	14x1.5	40
RB 4 RB 47	G 3/4 A M 27x2	17.05	10	24	5.8	3.8	12	18.77x1.78	80
RB 4 UN	1 1/16-12 UN	17.1	10	23.9	5.8	3.8	12	18.77x1.78	80

Housing version

TypeRK ... G, G-JIS RB ... G, G-JIS

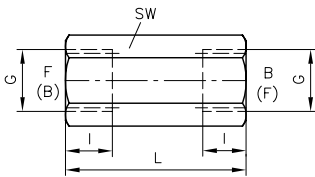

TypeRK ... E, E-JIS RB ... F

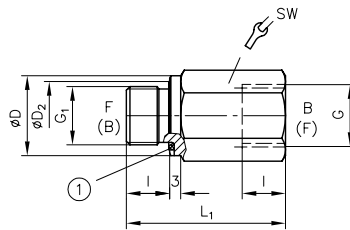

1 Thread seal

Cutting edge, except

- RK 1, RK 5 ... RK 7: Fitting seal
- RK...-JIS: O-ring
- RK...-UNF: O-ring

Type	G	G ₁	ØD	ØD ₂	L	L ₁	l	SW	Tightening torque (Nm)
RK 0 RK 0-... RB 0	G 1/8 (BSPP)	G 1/8 A (BSPP)	14	12.5	30	28	8	14	20
RK 0 UNF RB 0 UNF	7/16-20 UNF	7/16-20 UNF	14	--	36	33	11	17	8
RK 08 UNF RB 08 UNF	5/16-24 UNF	5/16-24 UNF	14	12.5	30	28	8	14	20
RK 1 RB 1	G 1/4 (BSPP)	G 1/4 A (BSPP)	19	--	46	43	12	19	40
RK 1 UNF RB 1 UNF	9/16-18 UNF	9/16-18 UNF	19	--	46	43	12	19	40
RK 1-...	G 1/4 (BSPP)	G 1/4 A (BSPP)	19	--	55	50	13	19	40
RK 1-...	G 1/4-JIS	G 1/4 A-JIS	19	--	58	47	12	19	40
RK 14 RB 14	M 14x1.5	M 14x1.5	19	--	46	42	12	19	40
RK 14-...	M 14x1.5	M 14x1.5	19	17	55	50	12	19	40
RK 16	M 16x1.5	M 16x1.5	21	20	50	44	12	22	80
RK 2 RB 2	G 3/8 (BSPP)	G 3/8 A (BSPP)	22	20.5	50	44	12	22	80
RK 2 UNF RB 2 UNF	3/4-16 UNF	3/4-16 UNF	22	20.5	50	44	12	22	80
RK 2-...	G 3/8 (BSPP)	G 3/8 A (BSPP)	22	20.5	60	50	13	22	80
RK 2-...	G 3/8-JIS	G 3/8 A-JIS	24	--	58	58	12	24	80
RK 28 RB 28	M 18x1.5	M 18x1.5	24	23	50	44	12	24	80
RK 28-...	M 18x1.5	M 18x1.5	23	20.5	60	60	13	24	80

Housing version

TypeRK ... G, G-JIS RB ... G, G-JIS

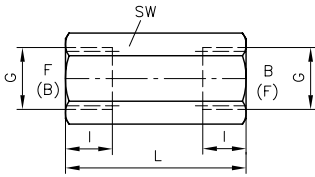

TypeRK ... E, E-JIS RB ... F

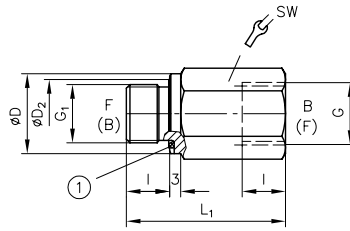

1 Thread seal

Cutting edge, except

- RK 1, RK 5 ... RK 7: Fitting seal
- RK...-JIS: O-ring
- RK...-UNF: O-ring

Type	G	G ₁	ØD	ØD ₂	L	L ₁	l	SW	Tightening torque (Nm)
RK 3 RB 3	G 1/2	G 1/2 A	26	24	56	52	14	27	150
RK 3 UNF RB 3 UNF	7/8-14 UNF	7/8-14 UNF	26	24	56	52	14	27	150
RK 3-...	G 1/2	G 1/2 A	27	25	68	63	14	27	150
RK 3-...	G 1/2-JIS	G 1/2 A-JIS	27	--	72	72	16	27	150
RK 32 RB 32	M 22x1.5	M 22x1.5	27	26	56	52	14	30	150
RK 32-...	M 22x1.5	M 22x1.5	27	25	68	63	14	27	150
RK 4 RB 4	G 3/4	G 3/4 A	32	30	65	60	16	36	200
RK 4 UN RB 4 UN	1 1/16-12 UN	1 1/16-12 UN	32	30	65	60	16	36	200
RK 4-...	G 3/4	G 3/4 A	32	30	82	80	16	36	200
RK 4-...	G 3/4-JIS	G 3/4 A-JIS	41	--	85	85	17	41	200
RK 47-...	M 27x2	M 27x2	32	30	82	80	17	36	200
RK 5	G 1	G 1 A	39.9	--	80	72	18	46	150
RK 6	G 1 1/4	G 1 1/4 A	49.9	--	98	85	22	55	250
RK 62	M 42x2	M 42x2	49.9	--	98	85	22	55	250
RK 6-...	G 1 1/4	G 1 1/4 A	49.9	--	125	120	22	55	250
RK 62-...	M 42x2	M 42x2	49.9	--	125	120	22	55	250
RK 7	G 1 1/2	G 1 1/2 A	54.9	--	105	95	30	60	300

4.1 Creating the mounting hole

For external line connection using pipe screw connection

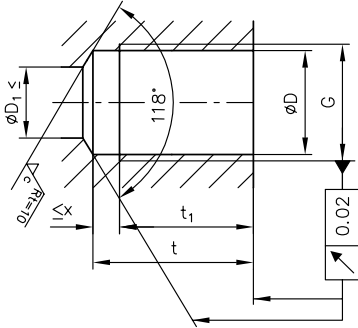

Note

End of the thread X adhere rigorously. Dimension X may be smaller, but not larger.

Type	G	ØD	ØD ₁	t	t ₁	x
RK 08, RB 08	M 8x1	7	4	17	15	2
RK 08-..., RB 08-...	5/16-24 UNF	6.8	4	17	15	2
RK 0, RK 0-..., RB 0	G 1/8 (BSPP)	8.7	5	16.5	14.2	2.3
RK 0-..., RB 0-...	7/16-20 UNF	9.8	5	16.5	14.2	2.5
RK 1, RB 1, RB 1-1	G 1/4 (BSPP)	11.8	8	22	19	3
RK 14, RB 14	M 14x1.5	12.5	8	22	19	3
RK 1-...	G 1/4 (BSPP)	11.8	6	36	31	5
RK 14-...	M 14x1.5	12.5	6	36	31	5
RK 16	M 16x1.5	14.5	8	22	19	3
RK 1-..., RB 1-...	9/16-18 UNF	12.8	8	36	31	3
RK 2, RB 2	G 3/8 (BSPP)	15.25	9	24.5	21.5	3
RK 28, RB 28	M 18x1.5	16.5	9	24.5	21.5	3
RK 2-...	G 3/8 (BSPP)	15.25	9	40	37	3
RK 28-...	M 18x1.5	16.5	9	40	37	3
RK 2-..., RB 2-...	3/4-16 UNF	17.4	9	40	37	3
RK 3, RB 3	G 1/2 (BSPP)	19	12	29	25.5	3.5
RK 32, RB 32	M 22x1.5	20.5	12	29	25.5	3.5
RK 3-...	G 1/2 (BSPP)	19	12	46	42.5	3.5
RK 32-...	M 22x1.5	20.5	12	46	42.5	3.5
RK 3-..., RB 3-...	7/8-14 UNF	20.3	12	46	42.5	3.5
RK 4, RK 4-..., RB 4	G 3/4 (BSPP)	24.5	16	35	31	4
RK 47, RK 47-..., RB 47	M 27x2	25	16	52	48.5	3.5
RK 4-..., RB 4-...	1 1/16-12 UN	24.7	16	35	31	4
RK 5	G 1	30.75	20	42	37	6
RK 6, RK 6-...	G 1 1/4	39.25	23	31	26	5
RK 62, RK 62-...	M 42x2	40	23	80	58	22
RK 7	G 1 1/2	45.25	30	60	50	10

For internal conduits

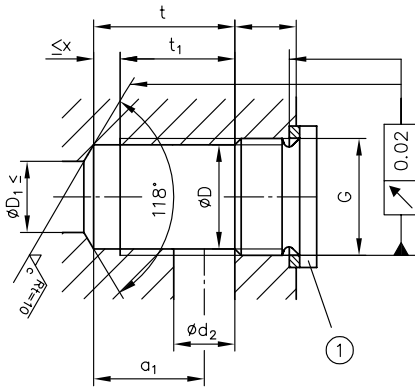

Note

End of the thread X adhere rigorously. Dimension X may be smaller, but not larger.

1 Example:
Tapped plug DIN 908

Type	G	ØD	ØD ₁	t	t ₁	x	a ₁	d ₂
RK 08, RB 08	M 8x1	7	4	8	6	2	8.5	4
RK 08-..., RB 08-...	5/16-24 UNF	6.8	4	9	7	2	7	4
RK 0, RK 0-..., RB 0	G 1/8 (BSPP)	8.7	5	11	8.7	2.3	9	4
RK 0-..., RB 0-...	7/16-20 UNF	9.8	5	11.5	9	2.5	9	5
RK 1, RB 1, RB 1-1	G 1/4 (BSPP)	11.8	8	14	11	3	11	6
RK 14, RB 14	M 14x1.5	12.5	8	14	11	3	11	6
RK 1-...	G 1/4 (BSPP)	11.8	6	28	23	5	19	6
RK 14-...	M 14x1.5	12.5	6	28	23	5	19	6
RK 16	M 16x1.5	14.5	8	14	11	3	11	6
RK 1-..., RB 1-...	9/16-18 UNF	12.8	8	16	13	3	12	8
RK 2, RB 2	G 3/8 (BSPP)	15.25	9	17	14	3	13	8
RK 28, RB 28	M 18x1.5	16.5	9	17	14	3	13	8
RK 2-...	G 3/8 (BSPP)	15.25	9	32.5	29.5	3	22	8
RK 28-...	M 18x1.5	16.5	9	32.5	29.5	3	22	8
RK 2-..., RB 2-...	3/4-16 UNF	17.4	9	18	15	3	13.5	9

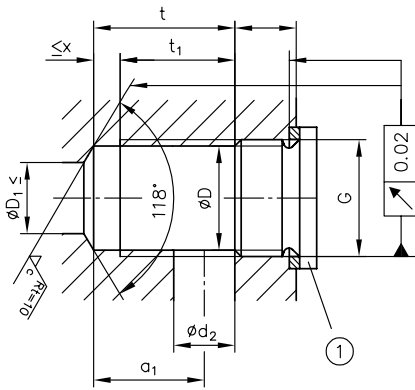
Note

End of the thread X adhere rigorously. Dimension X may be smaller, but not larger.

1 Example:
Tapped plug DIN 908

Type	G	ØD	ØD ₁	t	t ₁	x	a ₁	d ₂
RK 3, RB 3	G 1/2	19	12	22	18.5	3.5	16	12
RK 32, RB 32	M 22x1.5	20.5	12	22	18.5	3.5	16	12
RK 3-...	G 1/2	19	12	39	35.5	3.5	26.5	12
RK 32-...	M 22x1.5	20.5	12	39	35.5	3.5	26.5	12
RK 3-... , RB 3-...	7/8-14 UNF	20.3	12	22	18.5	3.5	16	12
RK 4, RK 4-... , RB 4	G 3/4	24.5	16	28	24	4	21	14
RK 47, RK 47-... , RB 47	M 27x2	25	16	28	24	4	21	14
RK 4-... , RB 4-...	1 1/16-12 UN	24.7	16	30	26	4	22	16
RK 5	G 1	30.75	20	71	65	6	--	20
RK 6	G 1 1/4	39.25	23	61	39	5	--	23
RK 62	M 42x2	40	23	61	39	5	--	23
RK 6-...	G 1 1/4	39.25	23	110	88	22	--	23
RK 62-...	M 42x2	40	23	110	88	22	--	23
RK 7	G 1 1/2	45.25	30	93	83	10	--	30

5**Installation, operation and maintenance information****5.1 Designated use**

This fluid-power product has been designed, manufactured and tested acc. to standards and regulations generally applicable in the European Union and left the plant in a safe and fault-free condition.

To maintain this condition and ensure safe operation, operators must observe the information and warnings in this documentation.

This fluid-power product must be installed and integrated in a hydraulic system by a qualified staff who is familiar with and observes the general engineering principles and relevant applicable regulations and standards.

In addition, application-specific features of the system or installation location must be taken into account if relevant.

This product may only be used within oil-hydraulic systems.

The product must be operated within the specified data. This documentation contains the technical parameters for various product versions.

**Note**

Non-compliance will void any warranty claims made against HAWE Hydraulik SE.

5.2 Assembly information

The hydraulic system be integrated in the equipment with standard connection components that comply with market requirements (screw fittings, hoses, pipes, etc.). The hydraulic system must be shut down correctly prior to dismantling; this applies in particular to systems with hydraulic accumulators.

5.2.1 Screw-in cartridge**Note**

If stronger surges or vibrations are to be anticipated due to the mode of operation of the system in which the valves are used, the valves must be protected against loosening when screwing into the bore holes provided using Loctite by way of precaution.

5.2.2 Creating the mounting hole

See description in [Chapter 4, "Dimensions"](#).

5.2.3 Assembly tool for type RK

(in-house production)

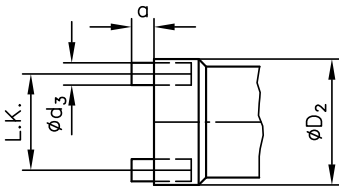

Type	$\varnothing D_2$	a	$\varnothing d_3$	L.K.	Tool
RK 08	6.9	1.5	1.1	4-8	W7-223/78
RK 0	8.6	2	1.2	6.9±0.05	W7-223/37
RK 1, RK 14	11.5	2.5	1.8	8.9 _{-0.1}	W7-223/23
RK 16	14	2.5	2.5	11 _{-0.1}	--
RK 2, RK 28	15	2	2.5	11.1 _{-0.1}	W7-223/24
RK 3, RK 32	18.5	4	3	14.3 _{-0.1}	W7-223/25
RK 4, RK 47	24	4	4	18.6	W7-223/26
RK 1-..., RK 14-...	11.45	2.5	1.6	8.95	W7-223/56
RK 2-..., RK 28-...	14.8	3	1.8	12.1	W7-223/58
RK 3-..., RK 32-...	18.5	4	2.7	14.95	W7-223/55
RK 4-..., RK 47-...	24	6	3.3	19	W7-223/66
RK 5	30	8	4	23	W7-223/91
RK 6, RK 62	38	6	5.5	30	W7-223/90
RK 6-..., RK 62-...	38	6	5.2	30	W7-223/76
RK 7	45	8	6.5	35.5	W7-223/94

5.3 Operating instructions

Product, pressure and/or flow settings

All statements in this documentation must be observed for all product, pressure and/or flow settings on or in the hydraulic system.

Filtering and purity of the hydraulic fluid

Soiling in the fine range, e.g. abraded material and dust, or in the macro range, e.g. chips, rubber particles from hoses and seals, can cause significant malfunctions in a hydraulic system. It is also to be noted that new hydraulic fluid "from the drum" does not necessarily meet the highest purity requirements.

Pay attention to the purity of the hydraulic fluid in order to maintain faultless operation (also see cleanliness level in [Chapter 3, "Parameters"](#)).

5.4 Maintenance information

This product is largely maintenance-free.

Conduct a visual inspection to check the hydraulic connections for damage at regular intervals, but at least once per year. If external leaks are found, shut down and remedy.

Check the device surfaces for dust deposits at regular intervals (but at least annually) and clean the device if required.

Further information

Additional versions

- Restrictor check valve type BC - Screw-in valve: D 6969 B
- Check valve type RC: D 6969 R
- Check valve type RE: D 7555 R
- Check valve type CRK, CRB and CRH: D 7712