

Variable displacement axial piston pump type V30E

Product documentation

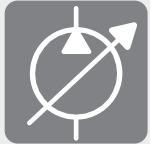

Open circuit

Nominal pressure $p_{\text{nom max}}$: 350 bar

Peak pressure p_{max} : 420 bar

Geometric displacement V_{max} : 270 cm³/rev

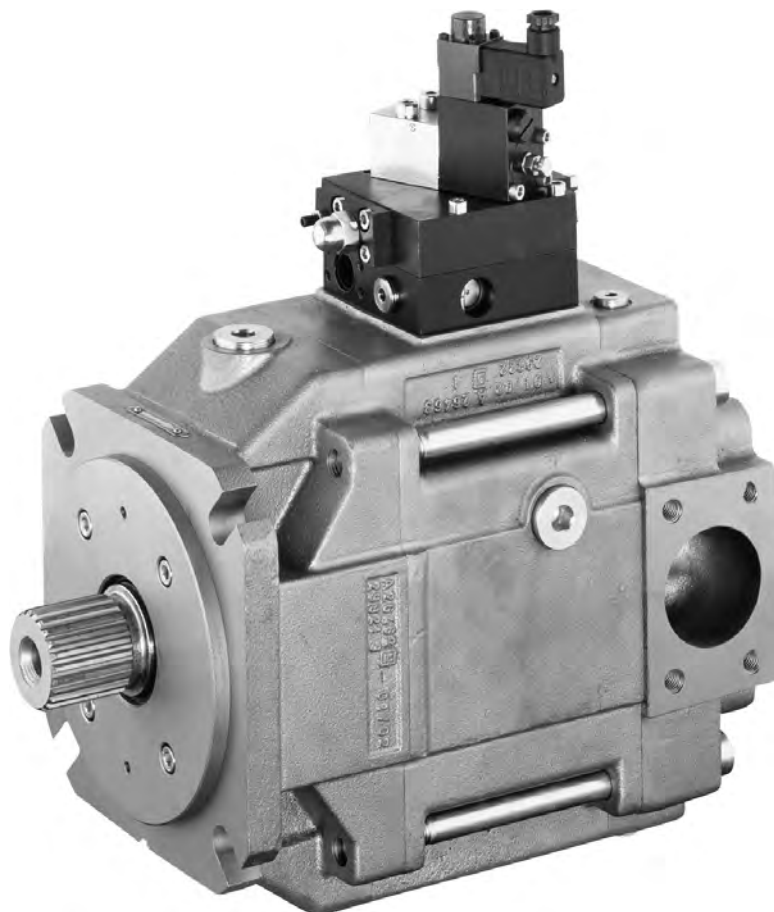

© by HAWE Hydraulik SE.

The forwarding and reproduction of this document, as well as the use and communication of its contents, are forbidden unless expressly permitted.

Any breach or infringement will result in liability for damages.

All rights reserved concerning patent or utility model registrations.

Contents

1	Overview: variable displacement axial piston pump types V30E.....	4
2	Available versions, main data.....	5
2.1	Basic version.....	5
2.2	Controller switching symbols.....	10
3	Parameters.....	13
3.1	General.....	13
3.2	Planning information for parameters.....	15
3.3	Characteristic curves.....	16
3.4	Pivoting angle pick-up.....	17
3.5	Controller characteristic curves.....	18
4	Dimensions.....	20
4.1	Basic pump.....	20
4.1.1	Type V30E-095.....	20
4.1.2	Type V30E-160.....	23
4.1.3	Type V30E-270.....	26
4.2	Pivoting angle indicator.....	29
4.3	Controller.....	29
4.4	Pump combinations.....	32
4.4.1	Pump combinations.....	32
4.4.2	Combination with dent pump.....	34
5	Installation information.....	35
5.1	General information.....	35
5.2	Ports.....	36
5.3	Installation positions.....	37
5.4	Tank installation.....	38
6	Installation, operation and maintenance information.....	39
6.1	Designated use.....	39
6.2	Assembly information.....	39
6.3	Operating instructions.....	40
6.4	Maintenance information.....	40

1 Overview: variable displacement axial piston pump types V30E

Variable displacement axial piston pumps adjust the geometric delivery volume from maximum to zero. As a result they vary the volumetric flow that is provided to the loads.

The axial piston pump type V30E is designed for open circuits in mobile hydraulics and works according to the swash plate principle. It is available with the option of a thru-shaft for operating additional hydraulic pumps in series. The sturdy pump is particularly suitable for continuous operation in challenging applications. The range of pump controllers allows the axial piston pump to be used in a variety of applications.

Features and benefits:

- Low noise emissions
- Wide range of controllers
- Full torque available at the second pump in tandem pump applications

Intended applications:

- Machines for forestry and agricultural purposes
- Cranes and lifting equipment
- Construction machines

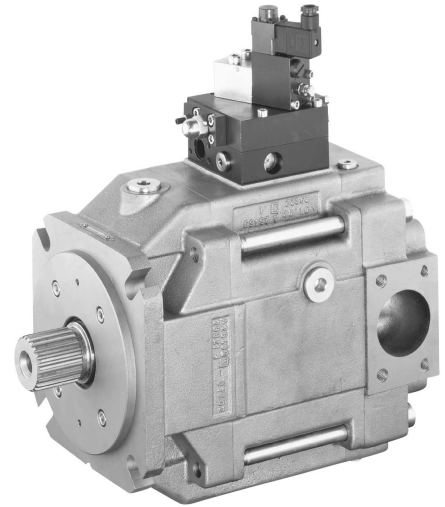

Figure 1: Variable displacement axial piston pump type V30E

2 Available versions, main data

2.1 Basic version

Circuit symbol:



Order coding example:

V30E	-095	R	D	G	N	- 2	- 0	- XX	/PL	- 200	C 211	- Z 05
												2nd pump
												2nd pump: see Chapter 4.4.2, "Combination with dent pump"
												Flange version
												Table 9 Flange versions (output side)
												Pressure specification (bar)
												Controller
												Table 8 Controllers
												Release
												Release
												Additional function
												Table 7 Additional functions
												Housing version
												Table 6 Housing versions
												Seal
												Table 5 Seals
												Flange version
												Table 4 Flange versions (input side)
												Shaft version
												Table 3 Shaft versions
												Rotating direction
												Table 2 Rotating directions
												Nominal size
												Table 1 Nominal size

Basic type

Table 1 Nominal size

Coding	Geometric displacement (cm ³ /rev.)	Nominal pressure p _{nom} (bar)	Peak pressure p _{max} (bar)
095	98	350	420
160	160	350	420
270	270	350	420

Table 2 Rotating directions

Coding	Description
L	Anti-clockwise
R	Clockwise



Note

When using HFC hydraulic fluid (Table 5, coding C), p_{max} = 300 bar

Table 3 Shaft versions

Coding	Description	Designation/Standard	Max. drive torque (Nm)
D	Spline shaft	W45x2x21x9g DIN 5480 (V30E-095)	1200
		W50x2x24x9g DIN 5480 (V30E-160)	1700
		W60x2x28x9g DIN 5480 (V30E-270)	3400
K	Parallel key	Ø40 - 12x8x80 DIN 6885 (V30E-095)	650
		Ø50 - 14x9x80 DIN 6885 (V30E-160)	850
		Ø60 - 18x11x100 DIN 6885 (V30E-270)	1700
S	Spline shaft	SAE-D J 744 13T 8/16 DP 44-4 ISO 3019-1 (V30E-095, V30E-160)	1200
		17T 8/16 DP (V30E-270)	3100
U	Spline shaft	SAE-D J 744 13T 8/16 DP 44-4 ISO 3019-1 (only V30E-270)	1200

Table 4 Flange versions (input side)

Coding	Description	Designation
G	Flange	160 B4 HW ISO 3019-2 (V30E-095)
		180 B4 HW ISO 3019-2 (V30E-160, V30E-270)
F	Flange	SAE-D 4-hole J 744 152-4 ISO 3019-1 (V30E-095, V30E-160)
		SAE-E 4-hole J 744 165-4 ISO 3019-1 (V30E-270)
W	Flange	SAE-D 4-hole J 744 152-4 ISO 3019-1 (V30E-270)

Table 5 Seals

Coding	Description
N	NBR
V	FKM
E	EPDM
C	FKM, suitable for HFC, see restrictions Chapter 5, "Installation information"

Table 6 Housing versions

Coding	Description
1	No thru-shaft
2	Thru-shaft for tandem pump



Table 7 Additional functions, pivoting angle indicator

Coding	Description
0	None
1	With indicator
2	With pivoting angle pick-up (Hall sensor)

Table 8 Controllers

Coding	Description
-... P -	Pressure controller with adjustable pressure on the integrated pilot valve and port for external pilot valve. The pressure controller automatically maintains a constant system pressure independently of the required delivery flow. Therefore, it is suited to constant pressure systems where differing delivery flows are required or for efficient pressure limitation of a hydraulic system.
-... Pb -	Coding Pb with external feedback of the pump pressure to compensate for a pressure loss in the pump pressure line.
-... LSP	Load-sensing controller with pressure limitation. Stand-by pressure adjustable from 15 ... 35 bar. Default differential pressure setting: 27 bar
-... LSPb	Coding LSPb with external feedback of the pump pressure to compensate for a pressure loss in the pump pressure line.
- PMVPS 4 - 41 /G 12 - 42 /G 24 - 43	<p>Pressure range -41: (5) ... 180 bar -42: (5) ... 290 bar -43: (5) ... 440 bar</p> <p>G ..: Solenoid voltage</p> <p>Additional, directly mounted proportional pressure-limiting valve for setpoint adjustment for the pressure controller (nominal voltage 12 V DC or 24 V DC with specification of the relevant max. pressure range). Can be combined with all controllers listed above. Valve type PMVPS 4 is used in accordance with D 7485/1 . Retrofitting is possible at any time.</p> <p>Order coding example: V30E-095 RDGN - 1 - 0 - XX / P - PMVPS 4 - 43 / G 24 - 350</p>
- BVPM 1 S /G 12 R /G 24	<p>S: Energised closed (deenergised open) R: Energised open (deenergised closed)</p> <p>Additional, directly mounted 2/2-way directional seated valve for pump direction switching (nominal pressure/stand-by pressure)</p> <p>Order coding example: V30E-095 RDGN - 1 - 0 - XX / P - BVPM 1 S / G 24 - 350</p>

Table 8 Controllers

Coding	Description
EM.CH	<p>The electro-hydraulic delivery flow controller adjusts the displacement volume of the pump between "zero" and "maximum" in proportion to an electrical input signal, (target 0 ... 10 V or 0 ... 20 mA). The power for the adjustment is taken from the high-pressure line. For system pressures below 50 bar, an additional auxiliary pump is required (thru-shaft). Corresponding auxiliary pump in accordance with Section 7.1: V30E-095: Z 02-5, V30E-160: Z 02-8, V30E-270: Z 02-10</p> <p>The control system consists of the pump adjustment system, an NG 6 prop. directional valve and a pivoting angle pick-up (coding 2) for actual value determination. Control electronics (coding CH, type DAC-4) compare the setpoint and actual values and supply the solenoid valves with the appropriate current. The control electronics used offer a wide range of options for individual adaptation, such as ramps and setpoint recall.</p> <div style="border: 1px solid #ccc; padding: 5px; margin-top: 10px;"> <p> Note The adjustment times are approx. 200 ms.</p> </div> <p>The adjustment can be combined with pressure controllers (coding P, PMVPS) and/or power controllers (coding L) to limit pressure and/or power.</p> <div style="border: 1px solid #ccc; padding: 5px; margin-top: 10px;"> <p> Note In addition, a separately assigned overpressure protection (pressure-limiting valve) is also to be provided in the hydraulic circuit to avoid pressure peaks.</p> </div> <p>Order coding example: V30E-095 RKGN - 2 - 2-XX / EMPCH - 250 - C212 - Z 02-6 (version with pressure limitation) V30E-270 RSFN - 2 - 2-XX / EMLSPCH / 1800 - 350 - C232 - Z 02-11 (version with load-sensing controller) V30E-160 RDGN - 2 - 2-XX / EMOCH - C222 - Z 02-9 (version without pressure limitation)</p>
L.	<p>The power controller with exact hyperbolic curve is used in the case of greatly varying pressures where the drive motor must also be protected against overloading. The drive torque is limited along the line "Pressure x Geometric displacement = Constant" by the special structure. If, for example, the pressure doubles at constant rotation speed, the delivery flow is automatically halved. External mechanical adjustment can be made to the drive torque at any time. Only in combination with pressure controller P. or load-sensing controller LSP. .</p> <p>Order coding example: V30E-160 RKGN - 0 - 1 - XX / LP / 180 - 300 V30E-095 RSFN - 1 - 1 - XX / LLSP / 120 - 200 - C 211</p>
Lf	<p>As for coding L. In addition, the set power can be changed (increased) by means of an applied control pressure.</p>
Lf1	<p>As for coding L. In addition, the set power can be changed (reduced) by means of an applied control pressure.</p>

Order coding example:

V30E-160 RDGN-2-0-04/LSP-350- C 222

Table 9 Flange versions (output side)

Coding V30E			Flange	Shaft	e.g. mounting of HAWE pump with coding
095	160	270			
C 211	C 221	C 231	SAE-A 2-hole J 744 82-2 ISO 3019-1	SAE-A J 744 (16-4 ISO 3019-1) 9T 16/32 DP	
C 212	C 222	C 232	SAE-A 2-hole J 744 82-2 ISO 3019-1	SAE-A J 744 (16-4 ISO 3019-1) 9T 16/32 DP ¹⁾	
C 213	C 223	C 233	SAE-A 2-hole J 744 82-2 ISO 3019-1	19-4 ISO 3019-1 11T 16/32 DP	
C 214	C 224	C 234	SAE-B 2-hole J 744 101-2 ISO 3019-1	SAE-B J 744 (22-4 ISO 3019-1) 13T 16/32 DP	V60N-060 .. HX
C 215	C 225	C 235	SAE-B 4-hole J 744 101-4 ISO 3019-1	SAE-B J 744 (22-4 ISO 3019-1) 13T 16/32 DP	V60N-060 .. HZ
C 216	C 226	C 236	SAE-B 2/4-hole 101-2/4 ISO 3019-1	SAE-BB J 744 (25-4 ISO 3019-1) 15T 12/24 DP	V40M
C 217	C 227	C 237	SAE-C 2-hole J 744 127-2 ISO 3019-1	SAE-C J 744 (32-4 ISO 3019-1) 14T 12/24 DP	
C 218	C 228	C 238	SAE-C 4-hole J 744 127-4 ISO 3019-1	SAE-C J 744 (32-4 ISO 3019-1) 14T 12/24 DP	V60N- .. SF
C 219	C 229	C 239	SAE-C 4-hole J 744 127-4 ISO 3019-1	23T 16/32 DP	
C 220	C 230	C 240	SAE-D 4-hole J 744 152-4 ISO 3019-1	SAE-D&E J 744 (44-4 ISO 3019-1) 13T 8/16 DP	V30E-095 ..SF.. /V30E-160 ..SF..
--	--	C 241	SAE-E 4-hole J 744 165-4 ISO 3019-1	17T 8/16 DP	V30E-270 ..SF..
C 247	C 248	C 249	Prepared for thru-shaft (cover)		
C 250	C 255	C 260	160 B4 HW ISO 3019-2	W45x2x21x9g DIN 5480	V30E-095 ..DG..
C 251	C 256	C 261	SAE-D 4-hole J 744 152-4 ISO 3019-1	W45x2x21x9g DIN 5480	V30E-095 ..DF..
--	C 257	C 262	180 B4 HW ISO 3019-2	W50x2x24x9g DIN 5480	V30E-160 ..DG..
--	C 258	C 263	SAE-D 4-hole J 744 152-4 ISO 3019-1	W50x2x24x9g DIN 5480	V30E-160 ..DF..
--	--	C 264	180 B4 HW ISO 3019-2	W60x2x28x9g DIN 5480	V30E-270 ..DG..
--	--	C 266	SAE-E 4-hole J 744 165-4 ISO 3019-1	W60x2x28x9g DIN 5480	V30E-270 ..DF..
C 252	C 259	C 268	180 B4 HW ISO 3019-2	Ø25 Key width 8	R size 6014 (D 6010) RZ size 6914 (D 6910)

Note

Pay attention to the maximum permissible drive torque, as the flange or shaft may be damaged otherwise.



Note

An additional support is to be provided for pump combinations.
Other versions on request.

¹⁾ ANSI B 92.1, FLAT ROOT SIDE FIT, spline width deviating from the standard, s = 2.357-0.03

2.2 Controller switching symbols

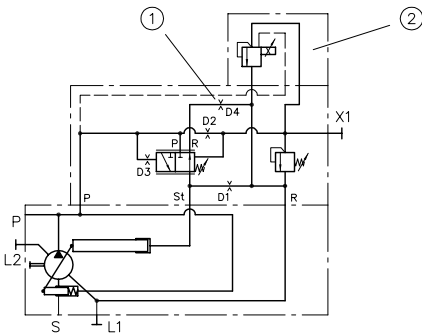
Coding P



- 1 Optional
- 2 Optional prop. pressure-limiting valve type PMVPS or type BVPM

Coding Pb

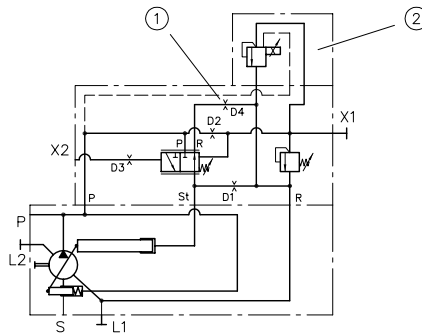

- 1 Optional
- 2 Optional prop. pressure-limiting valve type PMVPS or type BVPM

Coding LSP

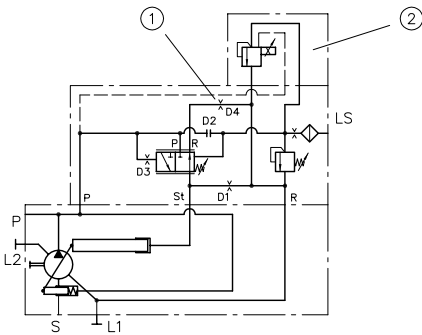

- 1 Optional
- 2 Optional prop. pressure-limiting valve type PMVPS or type BVPM

Coding LSPb

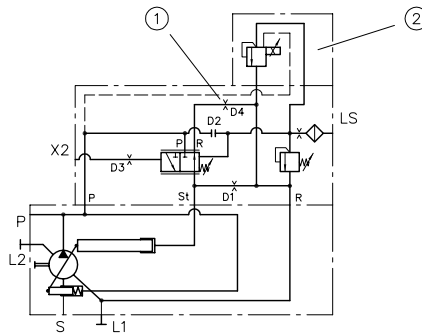

- 1 Optional
- 2 Optional prop. pressure-limiting valve type PMVPS or type BVPM

Coding PL

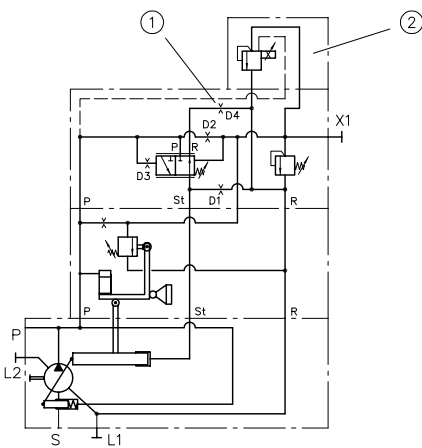

- 1 Optional
- 2 Optional prop. pressure-limiting valve type PMVPS or type BVPM

Coding LSPL

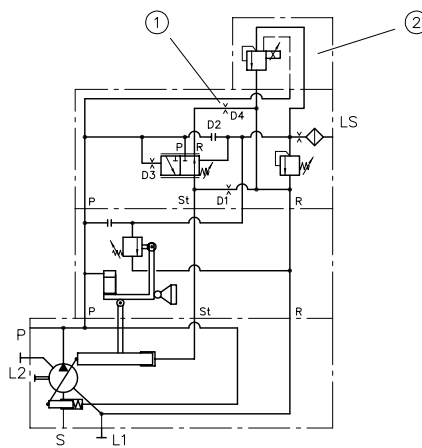

- 1 Optional
- 2 Optional prop. pressure-limiting valve type PMVPS or type BVPM

Coding PLf

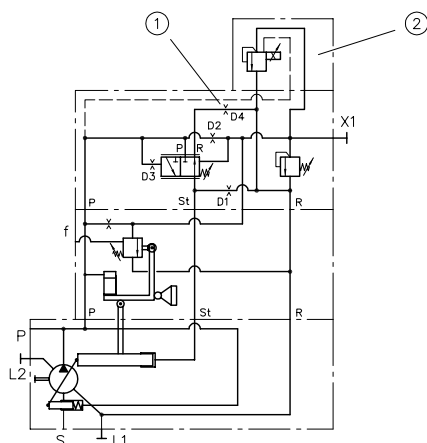

- 1 Optional
- 2 Optional prop. pressure-limiting valve type PMVPS or type BVPM

Coding PLf1

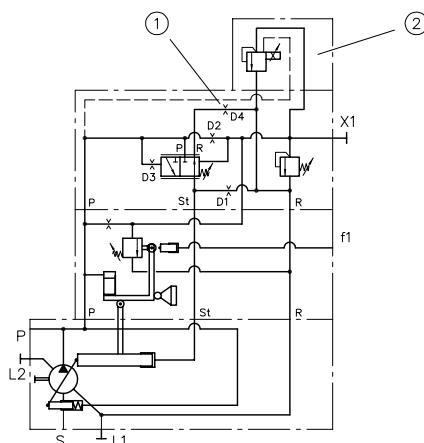

- 1 Optional
- 2 Optional prop. pressure-limiting valve type PMVPS or type BVPM

Coding BVPM1R

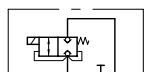

Coding BVPM1S

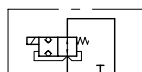

Coding EMOCH

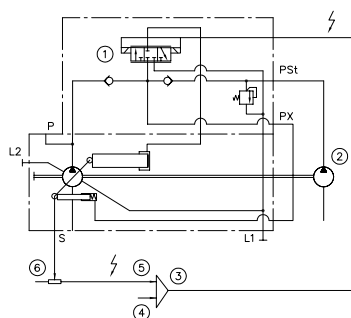

- 1 Prop. directional valve
- 2 Auxiliary pump
- 3 Amplifier card
- 4 NOMINAL
- 5 ACTUAL
- 6 Pivoting angle pick-up

S	Suction port
P	Pressure port
(L1) (L2)	Drain ports
X1	Remote-control port (add. pilot valves)
LS	LS pressure port (load-sensing pressure; downstream of measuring throttle in main circuit)
X2	External system pressure port
D1	Damping orifice
D2	Pilot orifice
D3	Damping orifice, control piston
D4	Orifice for on-stroke velocity

Coding EMPCH

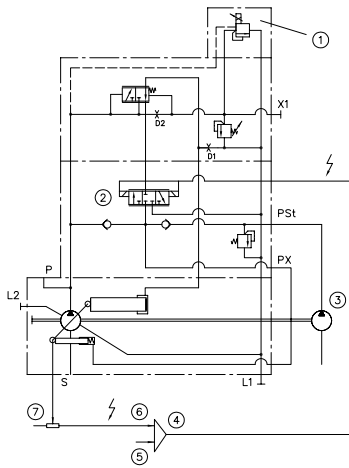

- 1 Optional prop. pressure-limiting valve type PMVPS or type BVPM
- 2 Prop. directional valve
- 3 Auxiliary pump
- 4 Amplifier card
- 5 NOMINAL
- 6 ACTUAL
- 7 Pivoting angle pick-up

Coding EMPLCH

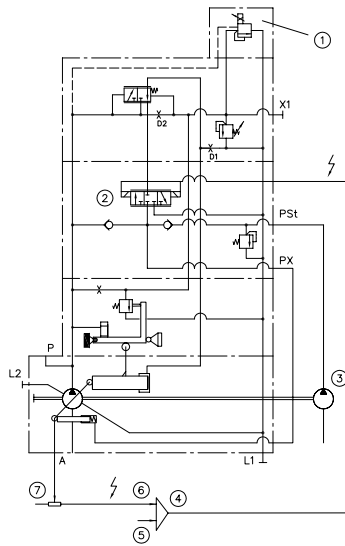

- 1 Optional prop. pressure-limiting valve type PMVPS or type BVPM
- 2 Prop. directional valve
- 3 Auxiliary pump
- 4 Amplifier card
- 5 NOMINAL
- 6 ACTUAL
- 7 Pivoting angle pick-up

3 Parameters

3.1 General

Description	Variable displacement axial piston pump
Design	Axial piston pump according to the swash plate principle
Mounting	Flange mounting or foot bracket
Surface	Primed
Drive/output torque	See Chapter 3, "Parameters" , under "Additional parameters"
Installation position	Any (for installation information see Chapter 5, "Installation information")
Rotating direction	Clockwise or anti-clockwise
Ports	<ul style="list-style-type: none"> ▪ Suction port ▪ Pressure port ▪ Drain port ▪ Pressure gauge connection
Hydraulic fluid	<p>Hydraulic oil: according to DIN 51 524 Part 1 to 3; ISO VG 10 to 68 according to DIN 51 519 Viscosity range: min. approx. 10; max. approx. 1000 mm²/s Optimal operating range: 16 to 35 mm²/s Also suitable for biologically degradable pressure fluids type HEPG (polyalkalene glycol) and HEES (synthetic ester) at operating temperatures up to approx. +70°C. HFC pressure fluids (water glycol); note installation information in Chapter 5, "Installation information".</p>
Purity class	<p>ISO 4406</p> <hr style="width: 20%; margin-left: 0;"/> <p>19/17/14</p>
Temperatures	<p>Ambient: approx. -40 to +60°C, oil: -25 to +80°C, pay attention to the viscosity range! Start temperature: down to -40°C is permissible (observe start-viscosity!), as long as the steady-state temperature is at least 20K higher for subsequent operation. Biologically degradable pressure fluids: note manufacturer specifications. With consideration for the seal compatibility, not above +70°C.</p>

Pressure and delivery flow

Operating pressure See [Chapter 2, "Available versions, main data"](#)

Geometric displacement See [Chapter 2, "Available versions, main data"](#)

Dimensions

Type V30E	Without controller (kg)	With controller (kg)			
		LSP, LSPb, P, Pb	PMVPS 4	L, Lf, Lf1	EM...
095	54	+2.5	+1.1	+2.5	+6.1
160	74	+2.5	+1.1	+2.5	+6.1
270	126	+2.5	+1.1	+2.5	+6.1

Additional parameters

Description	Nominal size		
	095	160	270
Max. swash plate angle	15°	15°	15°
Absolute inlet pressure required in open circuit	0.85 bar	0.85 bar	0.85 bar
Minimum operating pressure	15 bar	15 bar	15 bar
Max. permissible housing pressure (static/dynamic)	1 bar/2 bar	1 bar/2 bar	1 bar/2 bar
Max. rotation speed during suction operation and max. swash plate angle at 1 bar abs. Inlet pressure	2500 rpm	2100 rpm	1800 rpm
Max. rotation speed in supply mode	2900 rpm	2500 rpm	2000 rpm
Min. rotation speed in continuous operation	500 rpm	500 rpm	500 rpm
Required drive torque at 100 bar	153 Nm	261 Nm	414 Nm
Drive power at 250 bar and 1450 rpm	66 kW	107 kW	177 kW
Inertia torque	0.0216 kg m ²	0.03 kg m ²	0.0825 kg m ²
Service life L _h of shaft bearings at 250 bar, 1450 rpm and max. swash plate angle	20000 h	19000 h	20000 h
Noise level at 250 bar, 1450 rpm and max. swash plate angle (measured in acoustic measurement chamber according to DIN ISO 4412, measurement distance 1 m)	73 dB(A)	74 dB(A)	78 dB(A)

Note

The minimum operating pressure in the pump line depends on the speed and the pivoting angle; the pressure must not fall below 15 bar under any circumstances.

Note

The housing pressure is only allowed to be 1 bar higher than the suction pressure.

Max. permissible drive/output torque

Description		Nominal size		
		095	160	270
Spline shaft D	Drive/output	1200 Nm/600 Nm	1700 Nm/850 Nm	3400 Nm/1700 Nm
Parallel key K	Drive/output	650 Nm/600 Nm	850 Nm/850 Nm	1700 Nm/1700 Nm
Spline shaft S	Drive/output	1200 Nm/600 Nm	1200 Nm/850 Nm	3100 Nm/1700 Nm
Spline shaft U	Drive/output	--	--	1200 Nm/1200 Nm

3.2 Planning information for parameters

Determination of nominal sizes

Delivery flow	$Q = \frac{V_g \cdot n \cdot \eta_v}{1000} (l/min)$	V_g	= Geom. output volume (cm ³ /rev.)
Drive torque	$M = \frac{V_g \cdot \Delta p}{20 \cdot \pi \cdot \eta_{mh}} (Nm)$	Δp	= Differential pressure
Drive power	$P = \frac{2\pi \cdot M \cdot n}{60000} = \frac{Q \cdot \Delta p}{600 \cdot \eta_t} (kW)$	n	= Rotation speed (rpm)
		η_v	= Volumetric efficiency
		η_{mh}	= Mechanical-hydraulic efficiency
		η_t	= Overall efficiency ($\eta_t = \eta_v \cdot \eta_{mh}$)

3.3 Characteristic curves

Delivery flow and power (basic pump)

The diagrams illustrate the delivery flow/pressure (without controller).
Drive power at max. swash plate angle and drive power at zero stroke and 1500 rpm.
Drive power/pressure at zero stroke and 1500 rpm

Type V30E-095

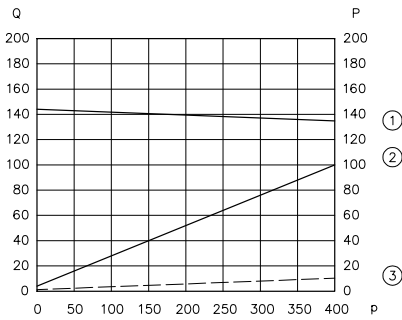

Figure 2: p pressure (bar); Q delivery flow (lpm); P power (kW)

- 1 Delivery flow/pressure
- 2 Drive power/pressure
- 3 Drive power/pressure (zero stroke)

Type V30E-160

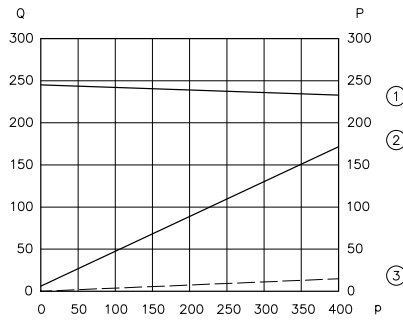

Figure 3: p pressure (bar); Q delivery flow (lpm); P power (kW)

- 1 Delivery flow/pressure
- 2 Drive power/pressure
- 3 Drive power/pressure (zero stroke)

Type V30E-270

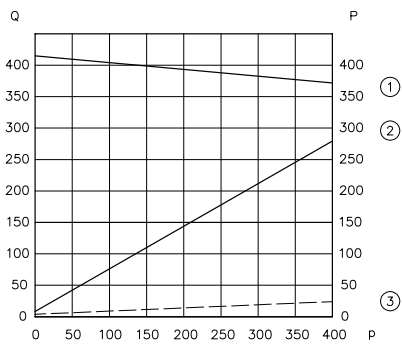

Figure 4: p pressure (bar); Q delivery flow (lpm); P power (kW)

- 1 Delivery flow/pressure
- 2 Drive power/pressure
- 3 Drive power/pressure (zero stroke)

Inlet pressure and self-suction speed

The diagrams show the inlet pressure/rotation speed at the max. swash plate angle and an oil viscosity of 75 mm²/s.

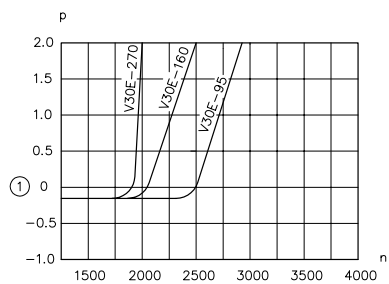
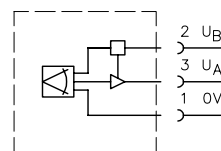
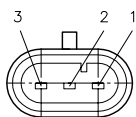
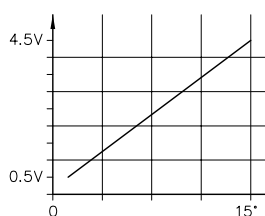

Figure 5: n rotation speed (rpm); p inlet pressure (bar)

1 0 bar relative = 1 bar absolute

3.4 Pivoting angle pick-up

Pivoting angle pick-up



Operating voltage	U_B 10 to 30 V DC
Output signal	U_A 0.5 to 4.5 V
Tested for automotive field	DIN 40839
Test pulse	1, 2, 3 a/b
Field control	200 V/m
Electrical connection	3-PIN AMP
Supersal	1.5 plug

3.5 Controller characteristic curves

Coding P

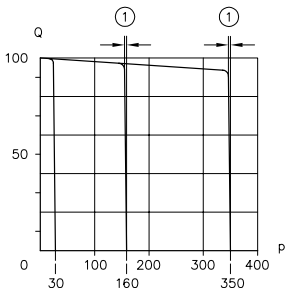

Figure 6: p pressure (bar); Q delivery flow (%)

1 3 bar deviation

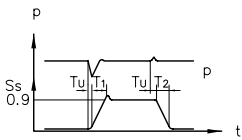

Figure 9: t in ms; p pressure (bar)

Coding LSP

Drive rotation speed constant

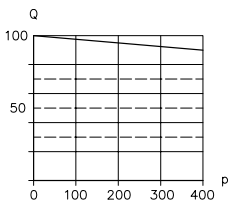

Figure 10: p pressure (bar); Q delivery flow (%)

LS line approx. 10% of the volume of the P line

Codings L, Lf, Lf1

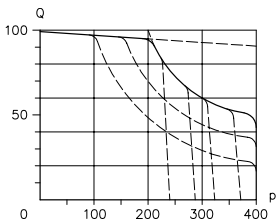

Figure 11: p pressure (bar); Q delivery flow (%)

Acting times T1

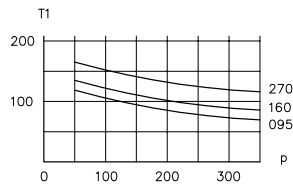

Figure 7: p pressure (bar); T1 acting time (ms)

Acting times T2

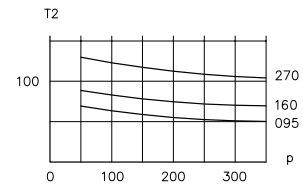

Figure 8: p pressure (bar); T2 acting time (ms)

S_s = positioning travel of actuator

T_u = delay < 3 ms

T_1 = on-stroke time

T_2 = destroke time

p = pressure

Parameters

Control accuracy in relation to max. delivery flow

- Rotation speed n constant, pressure variable between 30 and 350 bar (< 3%)
- Pressure p constant, rotation speed variable (< 1%)



Note

Smallest recommended nominal torque setting

Coding	Drive torque (Nm)	Corresponds to kW/rpm
095	99	15/1500
160	146	22/1500
270	300	45/1500

Codings EM..CH

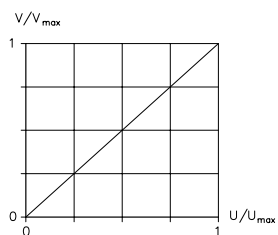

Figure 12: U/U_{max} input signal; V/V_{max} displacement volume

On-stroke time	270 ms ...180 ms
Destroke time	130 ms ...100 ms
Hysteresis and linearity	1 %
Amplifier card and controller card	Type DAC -4
- Supply voltage	18 ... 30 V DC, residual ripple < 10%
- Target value inputs	0 ... 10 V, 0 ... 20 mA
Proportional directional valve	4/3-way directional valve NG 6

Coding PMVPS 4

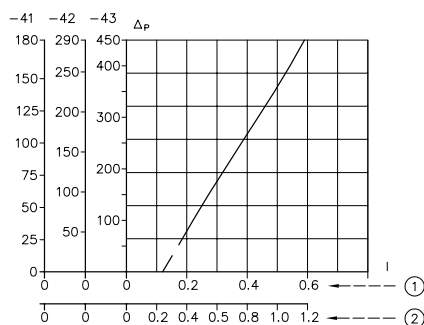

Figure 13: I current (mA); p pressure (bar)

- 1 At 24 V DC
- 2 At 12 V DC

Nominal voltage U_N	12V DC	24V DC
Nominal current I_N	1.26 A	0.63 A
Nominal power P_N	9.5 W	9.5 W
Protection class	IP 65 (IEC 60529) with connector installed as a precautionary measure	
Required dither frequency	60...150 Hz	
Dither amplitude	30 ... 60 % of I_N	
Further information	D 7485/1	
Electrical connection	Industry standard (11 mm)	



Coding BVPM 1

Nominal voltage U_N	12V DC	24V DC
Nominal current I_N	2.2 A	1.1 A
Nominal power P_N	29.4 W	27.6 W
Protection class	IP 65 (IEC 60529) with connector installed as a precautionary measure	
Further information	D 7765	
Electrical connection	DIN EN 175 301-803 A	



4 Dimensions

All dimensions in mm, subject to change!

4.1 Basic pump

4.1.1 Type V30E-095

Rotating direction **clockwise** (viewed from shaft journal)

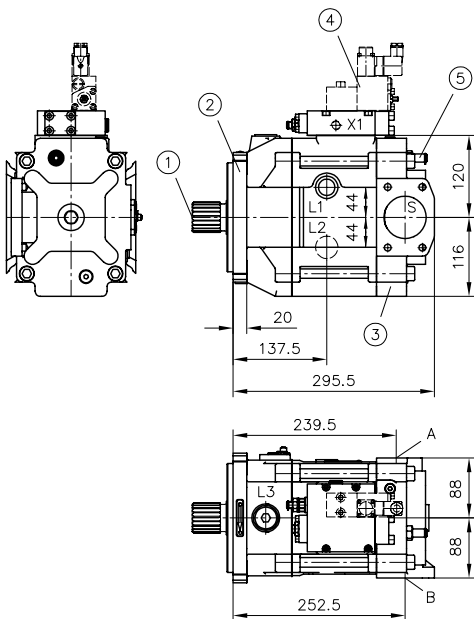

- 1 Shaft version
- 2 Flange version
- 3 Housing version
- 4 Controller
- 5 Stroke limitation (approx. 7.5 ccm/rev)

Rotating direction **anti-clockwise** (viewed from shaft journal)

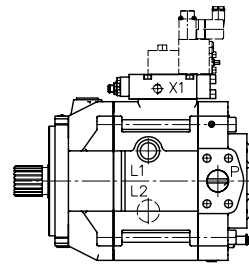

Rotating direction clockwise

Rotating direction anti-clockwise

A = pressure port

A = suction port

B = suction port

B = pressure port

Pressure port

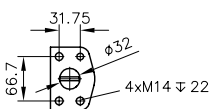

Suction port

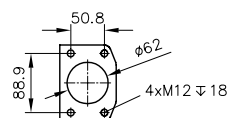

Shaft versions

Spline shaft

Coding **D**
(DIN 5480 W45x2x21x9g)

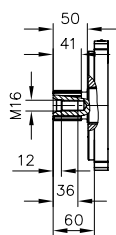

Spline shaft

Coding **S**
(SAE-D J 744 13T 8/16 DP)

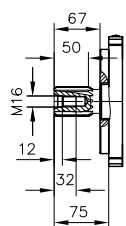

Parallel key shaft

Coding **K**
(DIN 6885 Ø40 - 12x8x80)

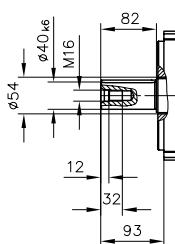

Flange versions

Coding G

(160 B4 HW ISO 3019-2)

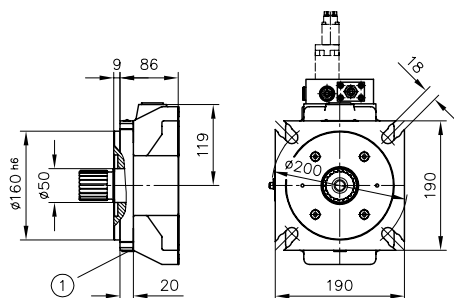

1 Bleeding and flushing port G1/4

Coding F

(SAE-D 4-hole J 744)
(152-4 ISO 3019-1)

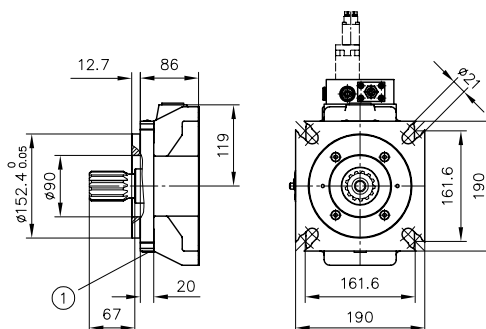

1 Bleeding and flushing port G1/4

Housing version -2 (radial ports, with thru-shaft)

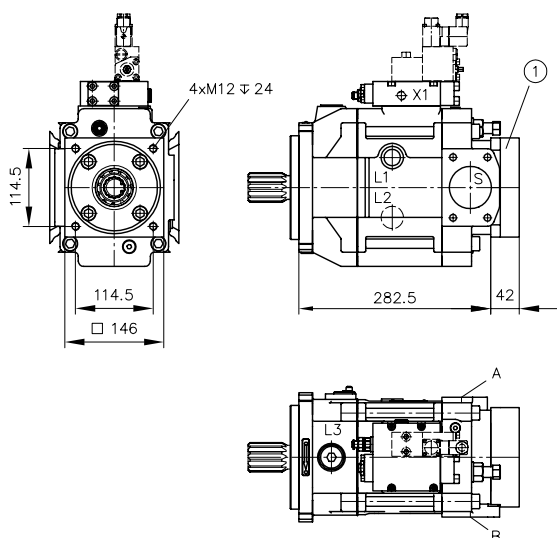

1 Flange version (output side)

Rotating direction clockwise

A = pressure port
B = suction port

Rotating direction anti-clockwise

A = suction port
B = pressure port

Flange version (output side)

Coding C211 and C212
(SAE-A 2-hole)

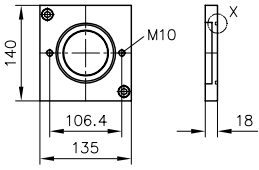

Coding C214 and C215
(SAE-B 2-hole and SAE-B 4-hole)

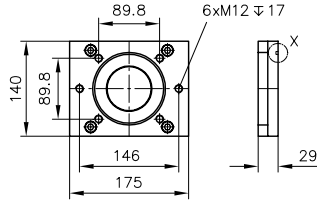

Coding C218
(SAE-C 4-hole)

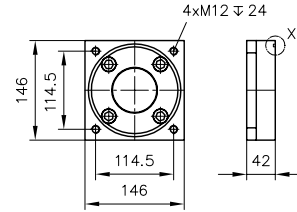

Coding C219
(SAE-C 4-hole and SAE-C 2-hole)

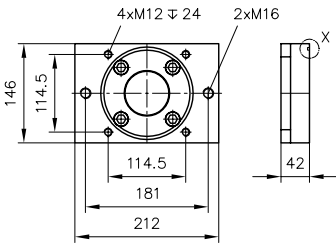

Coding C220
(SAE-D 4-hole)

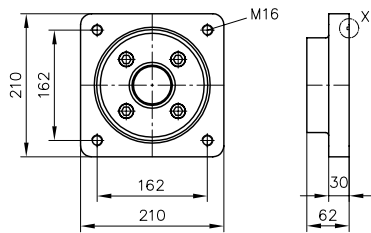

Coding C247
(prepared for thru-shaft (cover))

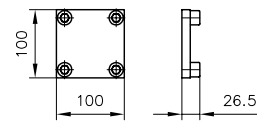

Detail X

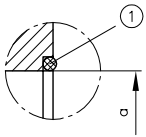

1 O-ring

V30E-095	Sealing ring	a
C211, C212	$\varnothing 84 \times 2$	$\varnothing 82.55^{+0.03}_{+0.01}$ 7 deep
C214, C215	$\varnothing 103 \times 2$	$\varnothing 101.6^{+0.03}_{+0.01}$ 11 deep
C218, C219	$\varnothing 132 \times 2$	$\varnothing 127^{+0.08}_{+0.04}$ 14 deep
C220	$\varnothing 164 \times 3$	$\varnothing 152.4^{+0.08}_{+0.04}$ 14 deep

Sealing ring included in the items supplied

4.1.2 Type V30E-160

Rotating direction **clockwise** (viewed from shaft journal)

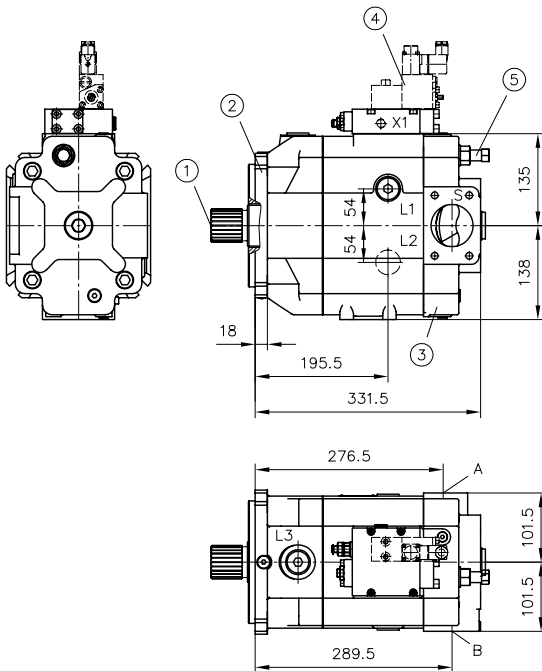

Rotating direction **anti-clockwise** (viewed from shaft journal)

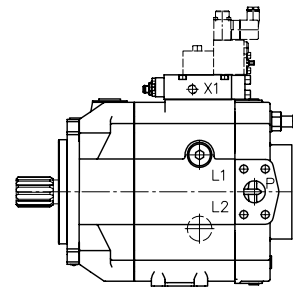

- 1 Shaft version
- 2 Flange version
- 3 Housing version
- 4 Controller
- 5 Stroke limitation (approx. 10 ccm/rev)

Rotating direction clockwise	Rotating direction anti-clockwise
A = pressure port	A = suction port
B = suction port	B = pressure port

Pressure port

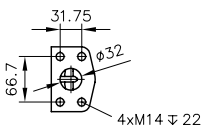

Suction port

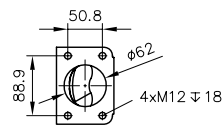

Shaft versions

Spline shaft

Coding **D**
(DIN 5480 W50x2x24x9g)

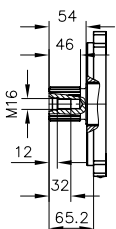

Spline shaft

Coding **S**
(SAE-D J 744 13T 8/16DP)

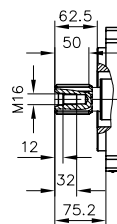

Parallel key shaft

Coding **K**
(DIN 6885 Ø50 - 14x9x80)

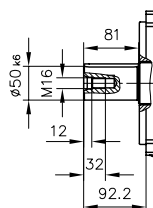

Flange versions

Coding G
(180 B4 HW ISO 3019-2)

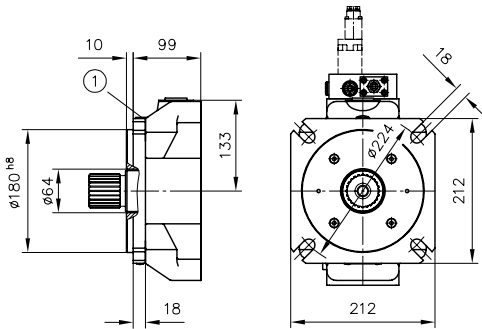

1 Bleeding and flushing port G1/4

Coding F
(SAE-D 4-hole J 744)
(152-4 ISO 3019-1)

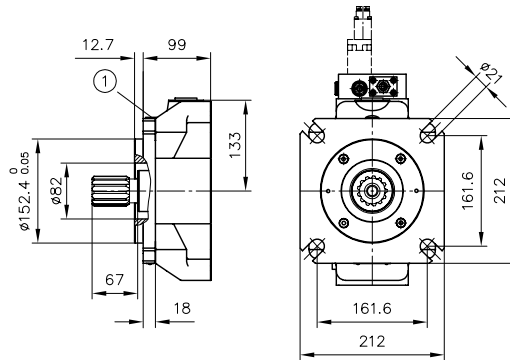

1 Bleeding and flushing port G1/4

Housing version -2 (radial ports, with thru-shaft)

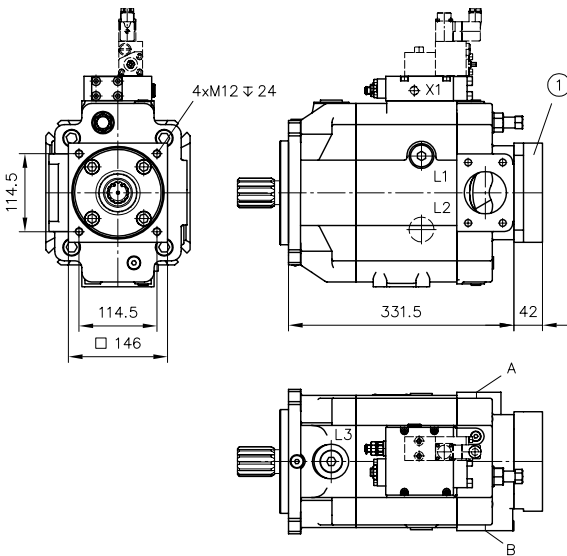

1 Flange version (output side)

Rotating direction clockwise	Rotating direction anti-clockwise
A = pressure port	A = suction port
B = suction port	B = pressure port

Flange version (output side)

Coding **C221 and C222**
(SAE-A 2-hole)

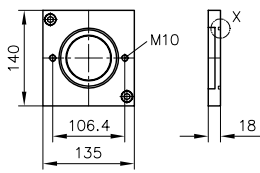

Coding **C224 and C225**
(SAE-B 2-hole and SAE-B 4-hole)

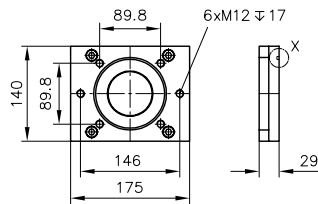

Coding **C228**
(SAE-C 4-hole)

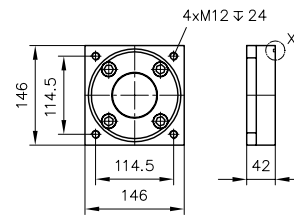

Coding **C227**
(SAE-C 2-hole and SAE-C 4-hole)

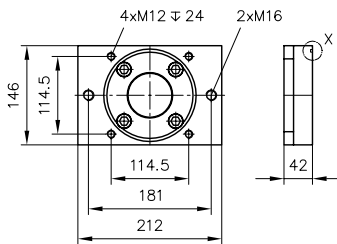

Coding **C230**
(SAE-D 4-hole)

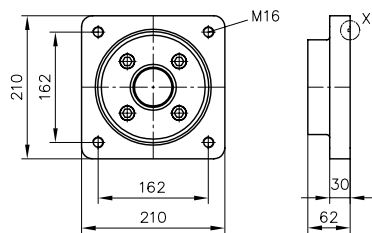

Coding **C248**
(prepared for thru-shaft (cover))

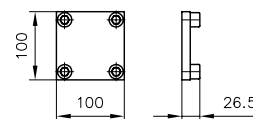

Detail X

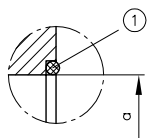

1 O-ring

V30E-160	Sealing ring	a
C221, C222	$\varnothing 84 \times 2$	$\varnothing 82.55^{+0.03}_{+0.01}$ 7 deep
C224, C225	$\varnothing 103 \times 2$	$\varnothing 101.6^{+0.03}_{+0.01}$ 11 deep
C227, 228	$\varnothing 132 \times 2$	$\varnothing 127^{+0.08}_{+0.04}$ 14 deep
C230	$\varnothing 164 \times 3$	$\varnothing 152.4^{+0.08}_{+0.04}$ 14 deep

Sealing ring included in the items supplied

4.1.3 Type V30E-270

Rotating direction **clockwise** (viewed from shaft journal)

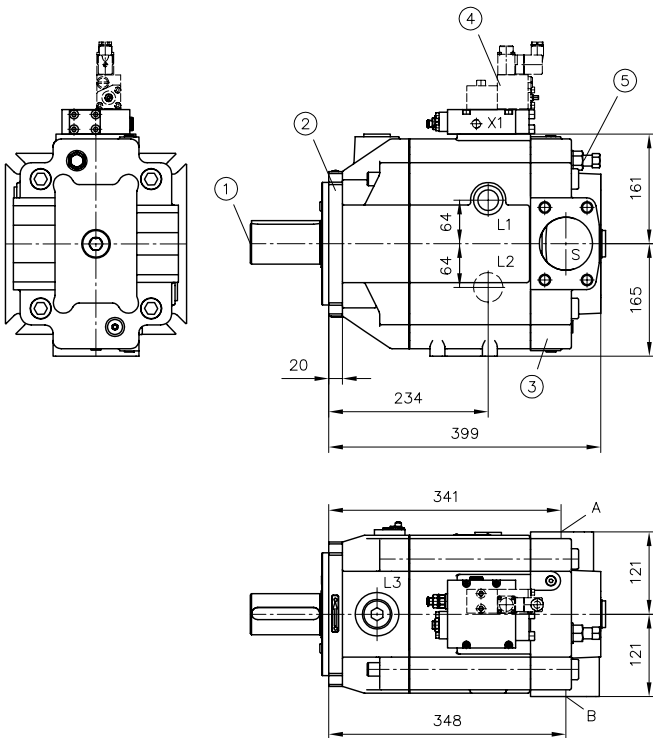

- 1 Shaft version
- 2 Flange version
- 3 Housing version
- 4 Controller
- 5 Stroke limitation (approx. 15 ccm/rev)

Rotating direction **anti-clockwise** (viewed from shaft journal)

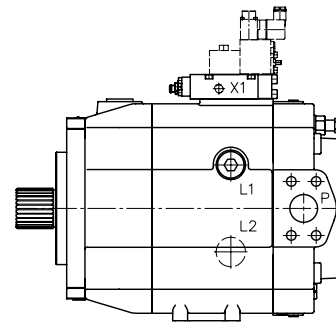

Rotating direction
clockwise

A = pressure port

B = suction port

Rotating direction anti-
clockwise

A = suction port

B = pressure port

Pressure port and suction port

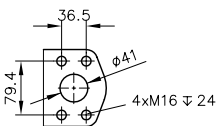

Figure 14: Pressure port

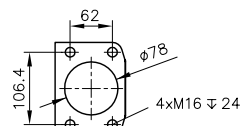
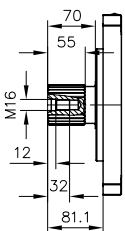

Figure 15: Suction port

Shaft versions

Spline shaft

Coding **D**
(DIN 5480 W60x2x28x9g)



Spline shaft

Coding **S**
(17T 8/16DP)

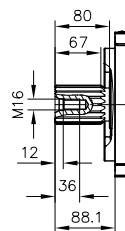

Spline shaft

Coding **U**
(SAE-D J 744 13T 8/16DP)

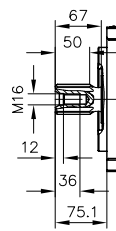

Parallel key shaft

Coding **K**
(DIN 6885 Ø60 - 18x11x100)

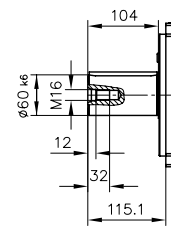

Flange versions

Coding G
(180 B4 HW ISO 3019-2)

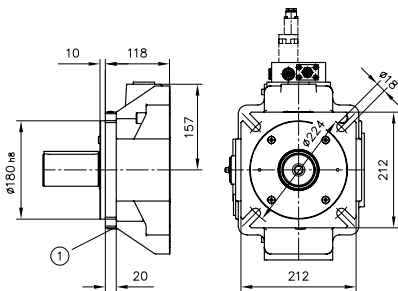

1 Bleeding and flushing port G1/4

Coding F
(SAE E-4-hole J 744)
(165-4 ISO 3019-1)

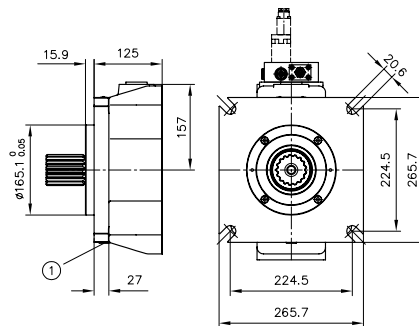

1 Bleeding and flushing port G1/4

Coding W
(SAE-D 4-hole J 744)
(152-4 ISO 3019-1)

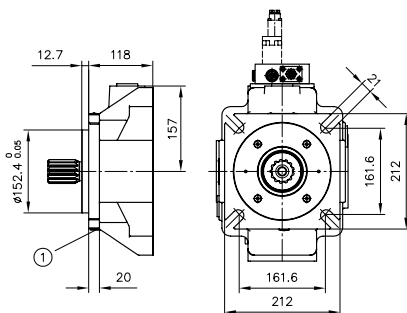

1 Bleeding and flushing port G1/4

Housing version -2 (radial version, with thru-shaft)

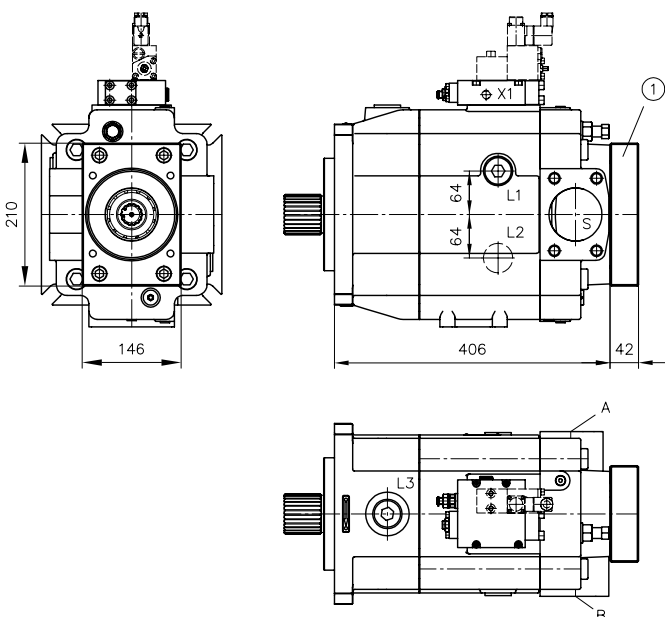

1 Flange version (input side)

Rotating direction clockwise	Rotating direction anti-clockwise
A = pressure port	A = suction port
B = suction port	B = pressure port

Flange version (output side)

Coding C231 and C232
(SAE-A 2-hole)

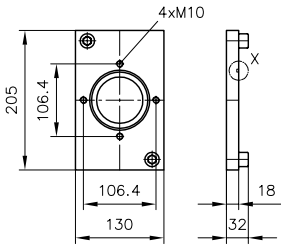

Coding C234
(SAE-B 2-hole and SAE-B 4-hole)

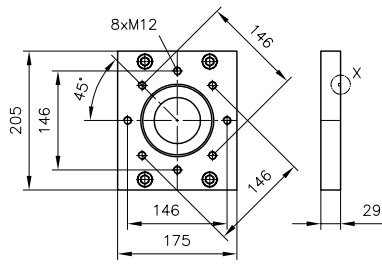

Coding C235
(SAE-B 4-hole)

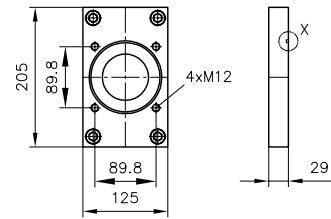

Coding C238
(SAE-C 4-hole)

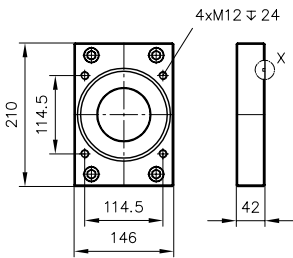

Coding C240
(SAE-D 4-hole)

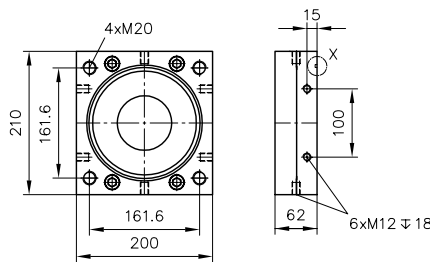

Coding C241
(SAE-E 4-hole)

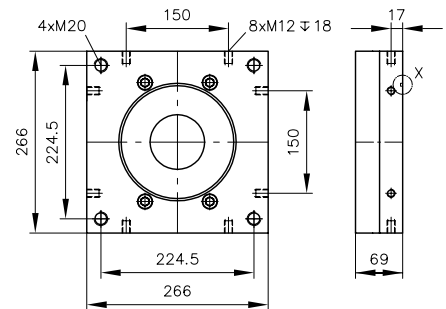

Coding C249
(prepared for thru-shaft (cover))

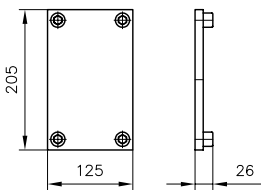

Detail X

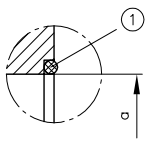

1 O-ring

V30E-270	Sealing ring	a
C231, C212	Ø 84x2	Ø 82.55 ^{+0.03} / _{+0.01} 7 deep
C234, C235	Ø 103x2	Ø 101.6 ^{+0.03} / _{+0.01} 11 deep
C228	Ø 132x2	Ø 127 ^{+0.08} / _{+0.04} 13 deep
C240	Ø 164x3	Ø 152.4 ^{+0.08} / _{+0.04} 13 deep
C241	Ø 167x3	Ø 165.1 ^{+0.08} / _{+0.04} 16 deep

Sealing ring included in the items supplied

4.2 Pivoting angle indicator

Pivoting angle indicator

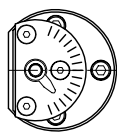

Pivoting angle pick-up

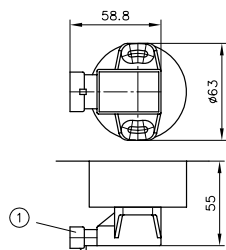

1 3-PIN AMP Superseal

4.3 Controller

Controller

Coding P and LSP

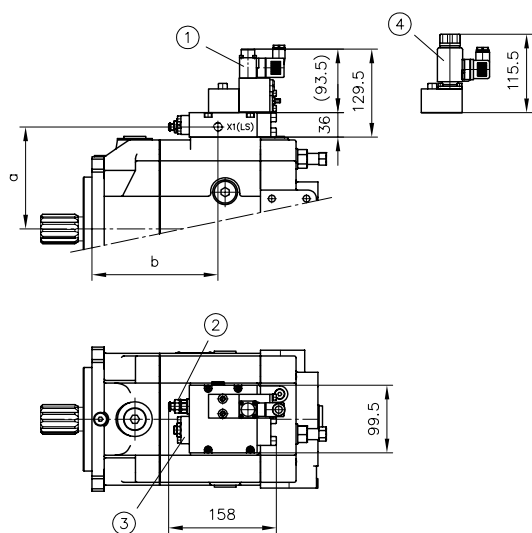

- 1 Prop. pressure-limiting valve type PMVPS 4 according to D 7485/1
- 2 Pressure setting (pressure controller)
- 3 LSP: setting of LS stand-by pressure; P: setting of p_{min}
- 4 2/2-way directional seated valve type BVPM

Coding LP and LLSP

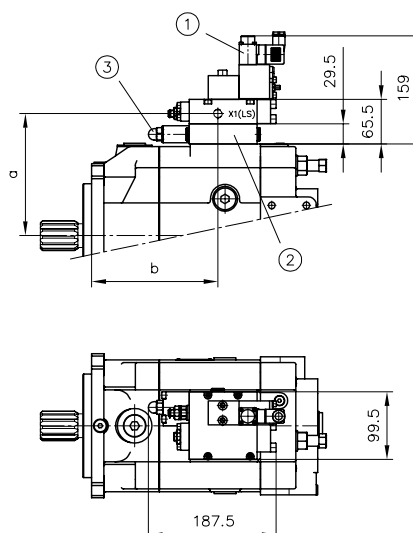

- 1 Prop. pressure-limiting valve type PMVPS 4 according to D 7485/1
- 2 Power controller (intermediate plate)
- 3 Power setting

	a	b	Power change/ revolution
V30E-095	135	151	140 Nm
V30E-160	150	185	237 Nm
V30E-270	176	223.5	400 Nm

	a	b	Power change/ revolution
V30E-095	164.5	151	140 Nm
V30E-160	179.5	185	240 Nm
V30E-270	205.5	223.5	400 Nm

Coding Pb and LSPb

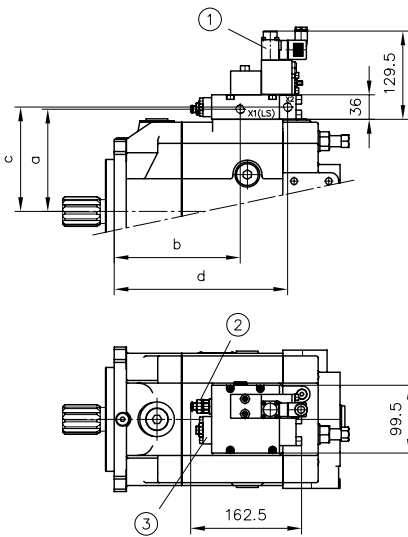

- 1 Prop. pressure-limiting valve type PMVPS 4 according to D 7485/1
- 2 Pressure setting (pressure controller)
- 3 LSP: setting of LS stand-by pressure; N: setting of p_{min}

	a	b	c	d
V30E-095	135	151	138	220.75
V30E-160	150	185	153	254.75
V30E-270	176	223.5	179	293.25

Ports (ISO 228/1)

LS, X1, X2 G 1/4

Coding Lf and Lf1

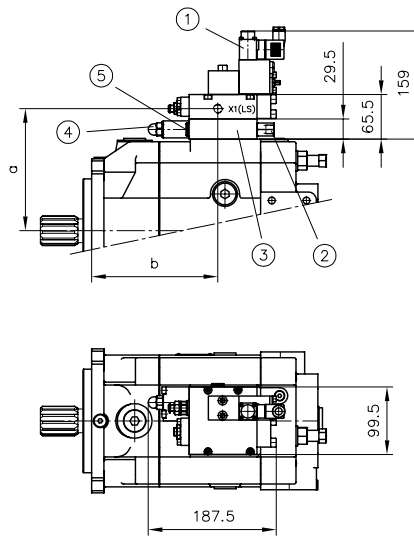

- 1 Prop. pressure-limiting valve type PMVPS 4 according to D 7485/1
- 2 Port f1 closed in case of Lf
- 3 Power controller (intermediate plate)
- 4 Power setting
- 5 Port f closed in case of Lf1

	a	b	Power change/ revolution
V30E-095	164.5	151	140 Nm
V30E-160	179.5	185	240 Nm
V30E-270	205.5	223.5	400 Nm

Coding **EM...** and **EML...**

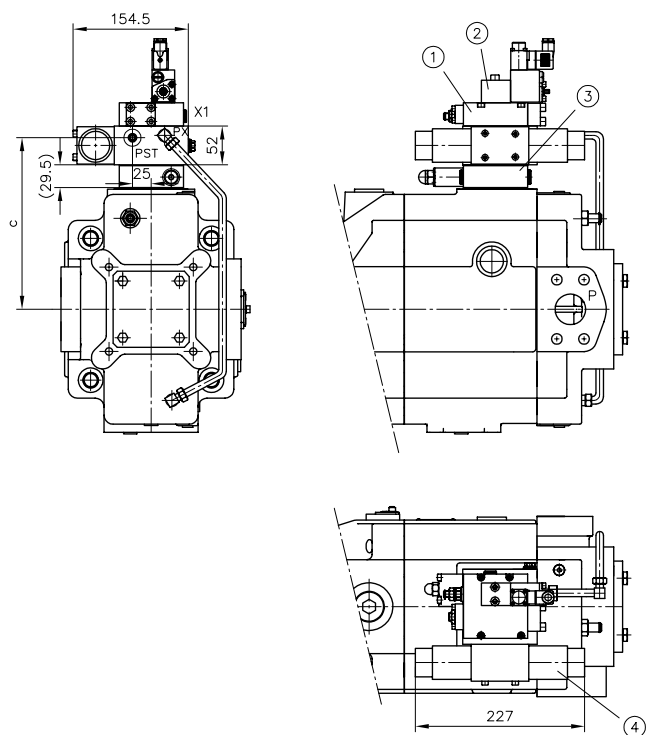

- 1 Pressure controller (option)
- 2 Prop. pressure-limiting valve type PMVPS 4 according to D 7485/1
- 3 Power controller (option)
- 4 Prop. directional spool valve

	c
V30E-095	156
V30E-160	169
V30E-270	197

Dimension "c" in version with power controller + 30 mm



Caution

Risk of injury on overloading components due to incorrect pressure settings!

- Always monitor the pressure gauge when setting or changing the pressure.

4.4 Pump combinations

4.4.1 Pump combinations

A support is to be provided for pump combinations installed horizontally.

Two variable displacement axial piston pumps can be coupled together using an intermediate flange. The sizing of the shafts also permits the transmission of the full torque to the second pump.

Same controller range as for individual pumps.

Available shaft designs: "D" and "S".

Flange versions available for tandem pumps, see [Chapter 2, "Available versions, main data"](#), Table 11

Order coding example

V30E-270 RDFN-2-2-02/EMP/120-200-C257-

(1. Pump)

(Type code see [Chapter 2, "Available versions, main data"](#))

V30E-160 RDGN-1-1-02/P/120-200

(2. Pump)

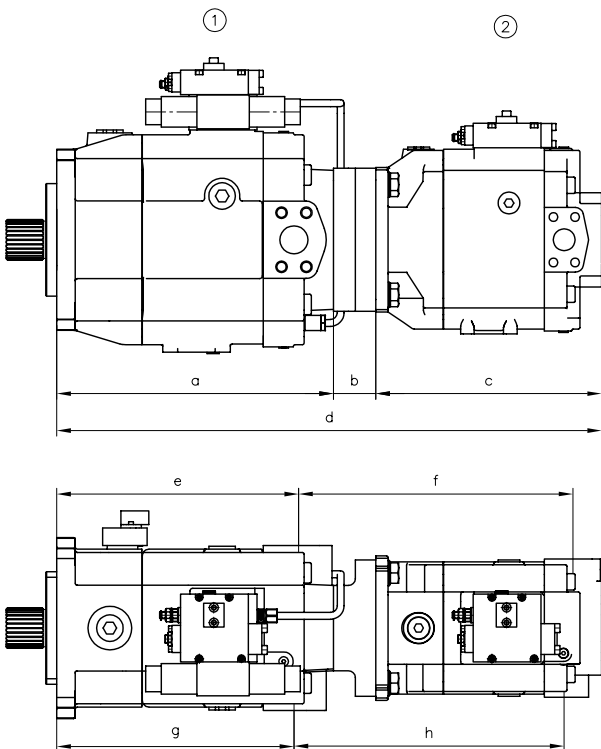

- 1 1st pump
- 2 2nd pump

Table of dimensions

1st pump	Coding	V30E-095 ..DG..-2-..-02								V30E-095 ..SF..-2-..-02							
2nd pump		a	b	c	d	e	f	g	h	a	b	c	d	e	f	g	h
V30E-095 ..DG..-1-..-02	C 250	282.5	47	296.5	625	252.5	329.5	239.5	329.5								
V30E-095 ..SF..-1-..-02	C 220									282.5	62	296.5	640	252.5	344.5	239.5	344.5

Table of dimensions

1st pump	Coding	V30E-160 ..DG..-2-..-02								V30E-160 ..SF..-2-..-02							
2nd pump		a	b	c	d	e	f	g	h	a	b	c	d	e	f	g	h
V30E-095 ..DG..-1-..-02	C 255	331.5	47	296.5	675	289.5	341.5	276.5	341.5								
V30E-095 ..SF..-1-..-02	C 230									331.5	62	296.5	690	289.5	356.5	276.5	256.5
V30E-160 ..DG..-1-..-02	C 257	331.5	52	344	727.5	289.5	383.5	276.5	383.5								
V30E-160 ..SF..-1-..-02	C 230									331.5	62	344	737.5	289.5	393.5	276.5	393.5

Table of dimensions

1st pump	Coding	V30E-270 ..DG..-2-..-02								V30E-270 ..SF..-2-..-02							
1st pump		a	b	c	d	e	f	g	h	a	b	c	d	e	f	g	h
V30E-095 ..DG..-1-..-02	C 260	399	47	296.5	742.5	348	350.5	341	344.5								
V30E-095 ..SF..-1-..-02	C 240									406	62	296.5	764.5	355	365.5	348	359.5
V30E-160 ..DG..-1-..-02																	
V30E-160 ..SF..-1-..-02	C 240									406	62	344	812	355	402.5	348	396.5
V30E-270 ..DG..-1-..-02																	
V30E-270 ..SF..-1-..-02	C 241									406	69	413	888	355	475	348	475

4.4.2 Combination with dent pump

A directly mounted auxiliary or additional gear pump is available.

All pipe work is fitted when a pump with electro-hydraulic prop. adjustment together with directly mounted auxiliary pump is ordered.

Order coding example

V30E-160 RKG N 2 -1 - XX / LSP / 280 - C 221 - Z 02-5

V30E basic pump

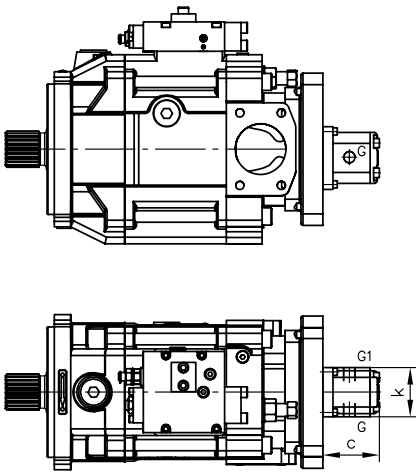

Coding	Geometric displacement V_g (cm ³ /rev.)	Auxiliary pump for	G (BSPP)	G1 (BSPP)	c	k
Z 02-6	6.0	V30E-095	G 3/8	G 3/8	77	68
Z 02-9	8.40	V30E-160	G 3/8	G 3/8	87	68
Z 02-11	10.80	V30E-270	G 3/8	G 3/8	98	89

Note
Auxiliary pump is required for the electro-hydraulic pump adjustment coding EM...

Note
With EM a gear pump twice as large as the auxiliary pump can be used on tandem pumps.

Note
Values "c" and "k" are reference values only.

Further characteristic values on request!

5 Installation information

5.1 General information

The V30E variable displacement axial piston pump is designed for use in an open circuit.

It can be mounted using a flange in accordance with specifications.

The various controllers can be fitted as intermediate plate versions or as separate devices as required.

The following essential points must be noted when installing the pump:

Mounting and removal of the pump and attached components may be performed by trained persons only. Ensure absolute cleanliness during all work. Contamination may have an adverse effect on the function and lifetime of the pump.

- Remove all plastic plugs prior to initial operation.
- Avoid installing the motor above the tank (see Installation positions" in [Chapter 5.3, "Installation positions"](#)).
- Observe the reference values in Section .
- Prior to initial operation, fill the pump with oil and bleed. Automatic pump filling via the suction line by opening the drain ports is not possible.
- Prevent the pump and suction line from running dry.
- Always ensure a constant supply of oil. Even a brief shortage in the supply of hydraulic fluid to the pump may damage internal parts. This may not be immediately evident after initial operation.
- The hydraulic oil returning to the tank from the system must not be sucked back in immediately (baffles).
- Run the pump for approx. 10 minutes at max. 50 bar after initial operation.
- Thorough bleeding/flushing of the entire system is recommended before the full pressure range is used.
- Observe the max. permissible operating range temperatures (see [Chapter 3, "Parameters"](#)) at all times.
- Always comply with the specified oil purity classes (see [Chapter 3, "Parameters"](#)); provide appropriate hydraulic fluid filtering.
- Use of a filter in the suction line must be approved by HAWE Hydraulik.
- Include a main pressure-limiting valve in the pressure line to limit the max. system pressure.

5.2 Ports

The nominal diameter of the connecting lines depends on the specified operating conditions, the viscosity of the hydraulic fluid, the start-up and operating temperatures and the rotation speed of the pump. In principle we recommend the use of hose lines due to the superior damping characteristics.

Bleeding and flushing port

The V30E pumps are fitted with a G 1/4" (BSPP) bleeding and flushing port. This is used to bleed and flush the front shaft bearing in the case of vertical installation.

Pressure port

The pressure port connection is established in the case of type V30E via SAE ports, see [Chapter 4, "Dimensions"](#). Metric attachment threads are used in deviation from the standard.

Observe the tightening torque specified by the fitting manufacturer.

Suction port

The suction port can be established via SAE ports; see [Chapter 4, "Dimensions"](#). Metric attachment threads are used in deviation from the standard.

If possible, route the suction line to the tank in such a way that it is steadily rising. This allows trapped air to escape. Observe the specifications in "Installation positions" [Chapter 5.3, "Installation positions"](#). The absolute suction pressure must not fall below 0.85 bar. A hose line should generally be used in preference to a rigid pipe.

Drain port

The V30E pumps have 3 drain ports G 3/4" (BSPP) or G 1" (BSPP).

The nominal diameter of the leakage line must not be less than 16 mm. The cross-section is determined by the max. permissible housing pressure.

Integrate the leakage line in the system in such a way as to prevent direct connection with the suction line of the pump.

All drain ports can be used simultaneously.

A separate leakage line from the controller to the tank is not required. Observe the specifications in [Chapter 5.3, "Installation positions"](#).

The top drain port can be used to fill the housing.

LS port for version LSP

The LS line is connected to the controller via a G 1/4" (BSPP) threaded connection.

The nominal diameter of the line depends on the installation position of the pump and should be 10% of the pressure line nominal volume. A hose line should generally be used in preference to a rigid pipe.

- When the proportional directional spool valve is in a neutral position, the LS line must be fully relieved (only controller type LSNR, LSN). In the case of controller type LSNRT, relief takes place internally in the controller.

For operation with HFC (35 - 50 % water content) the following restrictions apply

- The tank is above the pump
- The temperature does not exceed 50°C
- The fluid velocity in the suction line is below 1 m/s
- Pump pressure maximum 200 bar
- The two shaft bearings on a pump are flushed with cool oil via separate feeds, each bearing with 3 lpm (V30E-095), 4 lpm (V30E-160) and 5 lpm (V30E-270)

For operation with liquids with a water content ≤ 20 % the following restrictions apply

- The tank is above the pump
- The tank temperature does not exceed 70°C
- The fluid velocity in the suction line is below 1 m/s
- Pump pressure maximum 300 bar
- Possible without bearing flushing

5.3 Installation positions

The variable displacement axial piston pump V30E can be installed in any installation position.

A support is required for tandem pumps or multiple hydraulic pumps mounted in series. The following points must be observed:

Horizontal installation: (pump below the min. fill level)

For horizontal installation, use the uppermost drain port.

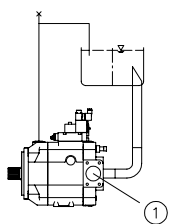

1 Suction port open

Vertical installation: (pump below the min. fill level)

Mount the pump so that the pump mounting flange is facing upwards. For vertical installation, use the uppermost drain port. Also connect the G 1/4" (BSPP) bleeding port on the pump flange. Take appropriate measures to ensure continuous bleeding of this line (line routing/bleeding).

For installation with the pump flange facing downwards, please contact HAWE Hydraulik.

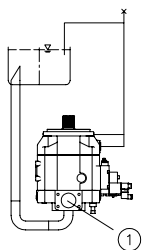

1 Suction port open

5.4 Tank installation

Tank installation (pump below the min. fill level)

The pump can be operated either with or without a suction tube. Using a short suction intake is recommended.

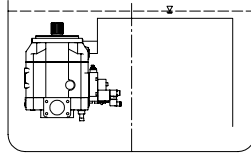
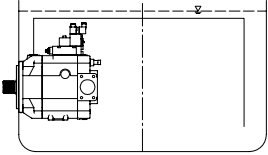

Additional notes regarding installation above the fill level

Special measures are required if the pump is installed above the fill level. The pump must not run dry via the pressure, intake, drain, bleed or control lines. This applies in particular to long periods of downtime.

- The leakage line must be installed in the tank in such a way that it ends below the oil level.
- Facilitate bleeding of connecting lines via separate bleed openings.
- Adjust the bleeding sequence to the specific installation.
- A gear pump must be provided in order to draw air from the suction line.

For specialist advice on designing axial piston pumps, the following contact form is available:
[Checklist for designing variable displacement axial piston pumps: B 7960 checklist.](#)

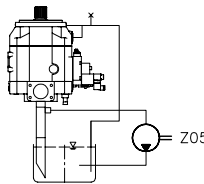
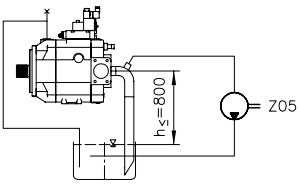

For further information on installation, operation and maintenance, see the relevant assembly instructions:
[B 7960](#), [B 5488](#).

6**Installation, operation and maintenance information****6.1 Designated use**

This fluid-power product has been designed, manufactured and tested using standards and regulations generally applicable in the European Union and left the plant in a safe and fault-free condition.

To maintain this condition and ensure safe operation, operators must observe the information and warnings in this documentation.

This fluid-power product must be installed and integrated in a hydraulic system by a qualified specialist who is familiar with and adheres to general engineering principles and relevant applicable regulations and standards.

In addition, application-specific features of the system or installation location must be taken into account if relevant.

This product may only be used as a pump within oil-hydraulic systems.

The product must be operated within the specified technical parameters. This documentation contains the technical parameters for various product versions.

**Note**

Non-compliance will void any warranty claims made against HAWE Hydraulik.

6.2 Assembly information

The hydraulic accumulator must be integrated in the system via state of the art connection components (screw fittings, hoses, pipes, etc.). The hydraulic system must be shut down as a precautionary measure prior to dismantling; this applies in particular to systems with hydraulic accumulators.

6.3 Operating instructions

Product, pressure and/or flow settings

All statements in this documentation must be observed for all product, pressure and/or flow settings on or in the hydraulic system.



Caution

Risk of injury on overloading components due to incorrect pressure settings!

- Always monitor the pressure gauge when setting or changing the pressure.

Filtering and purity of the hydraulic fluid

Soiling in the fine range, e.g. abraded material and dust, or in the macro range, e.g. chips, rubber particles from hoses and seals, can cause significant malfunctions in a hydraulic system. It is also to be noted that new hydraulic fluid "from the drum" does not necessarily meet the highest purity requirements.

For trouble-free operation pay attention to the purity of the hydraulic fluid (see also purity class in [Chapter 3, "Parameters"](#)).

6.4 Maintenance information

This product is largely maintenance-free.

Conduct a visual inspection to check the hydraulic connections for damage at regular intervals, but at least once per year. If external leaks are found, shut down and remedy.

Check the device surfaces for dust deposits at regular intervals (but at least annually) and clean the device if required.

Additional versions

- General operating manual for the assembly, initial operation and maintenance of hydraulic components and systems: B 5488
- Variable displacement axial piston pump type V60N: D 7960 N
- Variable displacement axial piston pump type V40M: D 7961
- Variable displacement axial piston pump type V30D: D 7960
- Fixed displacement axial piston pump type K60N: D 7960 K
- Axial piston motors type M60N: D 7960 M
- Proportional directional spool valve, type PSL and PSV size 2: D 7700-2
- Proportional directional spool valve, type PSL, PSM and PSV size 3: D 7700-3
- Proportional directional spool valve, type PSL, PSM and PSV size 5: D 7700-5
- Proportional directional spool valve type PSLF, PSVF and SLF size 3: D 7700-3F
- Proportional directional spool valve type PSLF, PSVF and SLF size 5: D 7700-5F
- Proportional directional spool valve banks, type PSLF, PSVF and SLF size 7: D 7700-7F
- Load-holding valve type LHT: D 7918
- Load-holding valve type LHDV: D 7770
- Proportional amplifier type EV1M3: D 7831/2
- Proportional amplifier type EV1D: D 7831 D