

# Variable displacement axial piston pump type V30D

for open circuit

**In/line**

Pressure  $p_{\max}$  = 420 bar (6000 psi)  
Displacement  $V_{\max}$  = 260 cm<sup>3</sup>/rev (16.16 cu in/rev)

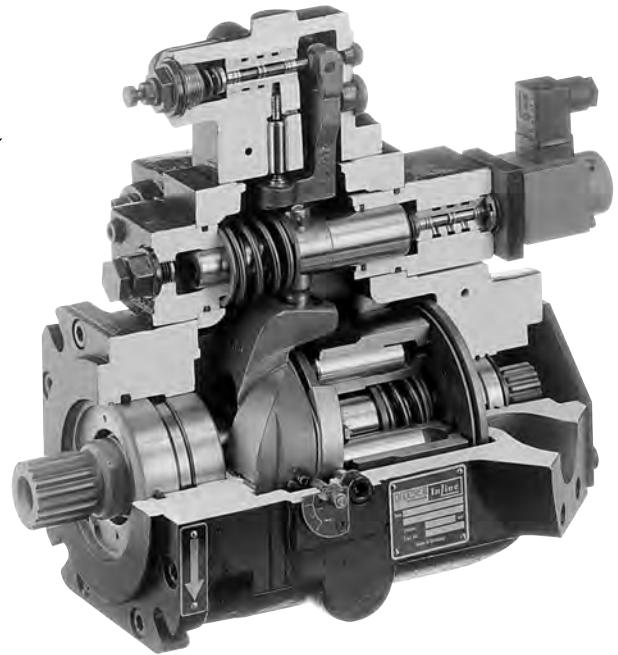
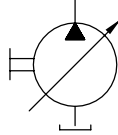

1.2

## 1. General description

The axial piston variable displacement pumps of the type V30 of D offer extremely high function safety. Its remarkably low noise levels, the high pressure rating (peak = 420 bar / perm. = 350 bar), optimised power-to-weight-ratio as well as the wide controller range make it possible to employ it for most industrial and mobile applications. The variable displacement pumps work according to the swash plate principle: 9 pistons operate in a rotating cylinder cavities where they fulfill one suction and one pressure stroke per rotation.

Opening and closing of the cylinder cavities is via openings in the control disc. The axial movement of the pistons is provided by an adjustable swash plate. The setting angle (0 - max) can be steplessly varied in proportion to the desired displacement/flow. The setting range can be mechanically limited by setting screws (with V and VH controller only fixed limitation is possible). The position of the swash plate can be controlled via a visual mechanical indicator.

The latest knowledge and experience with regard to noise reduction has been used in the development of this pump design. V30D is therefore rather quiet, even when taken to the limit. All components used in the V30D are manufactured from high grade materials and machined with close tolerances.

The wide range of modular controllers along with a thru-shaft (option for mounting auxiliary pumps or a second V30D) open up a wide range of application possibilities.

Therefore type V30D features a pump design, which ideally suits the special requirements of modern industrial and mobile hydraulic drive systems

### Outstanding design features:

- Low specific weight
- Very fast response times due to low mass moment of inertia of the setting unit
- Special swash plate bearing helps reduce noise
- New design of the hydrostatically balanced steel slipper shoes running on a bronze plate improves the life of typical wearing parts
- Valve plate made from steel provides high wear resistance. Carefully designed dampening slots result in exceptionally low noise level
- Large shaft bearings provide long life

### The most important advantages:

- Low noise level, whereby secondary measures to reduce noise often are not necessary
- Controller assemblies have been designed on a modular basis and can be installed without dismantling the basic pump
- Thru- shaft allows tandem pump combinations and mounting of auxiliary pumps of all kinds (see sect. 5)
- Swash plate dial indicator provides visual indication of displacement and can also be used to provide feedback information in control systems

**HAWE**  
HYDRAULIK

HAWE HYDRAULIK SE  
STREITFELDSTR. 25 • 81673 MÜNCHEN

**D 7960**  
Variable displacement  
axial piston pump

## 2. Available versions, main data (see also drawings page 4)

### Calculation:

Unit conversion, see page 12 below

Flow rate  

$$Q = \frac{V_g \cdot n \cdot \eta_v}{1000} \text{ (lpm)}$$

Torque  

$$M = \frac{1.59 \cdot V_g \cdot \Delta p}{100 \cdot \eta_{mh}} \text{ (Nm)}$$

Power  

$$P = \frac{2 \cdot M \cdot n}{60 \cdot 1000} = \frac{M \cdot n}{9549} = \frac{Q \cdot \Delta p}{600 \cdot \eta_t} \text{ (kW)}$$

$V_g$  = Displacement [cm<sup>3</sup>/rev]  
 $\Delta p$  = Diff. pressure [bar]  
 $n$  = Speed [rpm]

$\eta_v$  = Volumetric efficiency  
 $\eta_{mh}$  = Mechanical efficiency  
 $\eta_t$  = Total efficiency ( $\eta_t = \eta_v \cdot \eta_{mh}$ )

Order example:

**V30D - 095 R K N - 1 - 1 - XX/LN - 2/120 - 200**

Basic type \_\_\_\_\_

Pressure (bar)<sup>4)</sup>

see tab. 2 below

Torque setting in Nm<sup>3)</sup>  
 (1 Nm = 0.741 lbf ft)  
 (alternative power in kW and speed in rpm as additional text)

Special versions:<sup>5)</sup>  
**1** = Prepared for L-controller  
**2** = With stroke limitation

HAWE serial no.

Swash angle indicator: **0** = without indicator  
**1** = with indicator

Shaft design: **1** = Standard  
**2** = Thru-shaft  
 (see also sect. 5)

Shaft seals:  
**N** = NBR (Nitril)  
**E** = EPDM<sup>2)</sup>  
**V** = FKM (Viton)<sup>2)</sup>

Shaft:  
**D** = Spline shaft (DIN 5480)  
**K** = Key shaft  
**S** = Spline shaft and flange SAE

1) Higher pressure is only possible with reduce displacement

2) Special versions

3) Spec. required with controller coding L, LF1

4) Spec. required with controller coding N, LSN

5) Combinations are possible (-1-2)

6) See foot note 2), page 5

**Table 1:** Designation

Coding	045	075	095	115	140	160	250
Displacement cm <sup>3</sup> /rev. (cu. in./rev.)	45 (2.75)	75 (4.58)	96 (5.86)	115 (7.02)	142 (8.66)	164 (9.90)	260 <sup>6)</sup> (16.16)
Flow (theor.) at 1450rpm [lpm] (1800 rpm [gpm])	65 (21.4)	109 (35.7)	139 (45.7)	167 (54.7)	206 (67.6)	238 (77.3)	356 (99.9)
Max. continuous pressure bar (psi)	350 (5000)	350 (5000)	350 (5000)	250 <sup>1)</sup> (3600) <sup>1)</sup>	350 (5000)	250 <sup>1)</sup> (3600) <sup>1)</sup>	350 (5000)
Max. peak pressure bar (psi)	420 (6000)	420 (6000)	420 (6000)	300 <sup>1)</sup> (4300) <sup>1)</sup>	420 (6000)	300 <sup>1)</sup> (4300) <sup>1)</sup>	420 (6000)
Max. case pressure bar (psi) <sup>2)</sup>	1.0 (15)	1.0 (15)	1.0 (15)	1.0 (15)	1.0 (15)	1.0 (15)	1.0 (15)

Direction of rotation: **L** = Left hand  
**R** = Right hand  
 (facing the drive shaft)

**Table 2:** Controller

Coding	Description
<b>L</b>	The V30D pump with power controller is used in applications with highly varying pressure demands and where it is important to protect the electric motor (engine) from overload. The controller limits the hydraulic power (at constant shaft speed) according to the ideal curve "pressure x flow = constant". The product of pressure and flow cannot exceed the pre-set power value. If, for example, the pressure doubles (at max power) the flow is automatically reduced by 50%.
<b>Lf1</b>	Means that there is a hydraulic displacement limiter included. The displacement can be reduced by a pilot pressure from an outside source.
<b>LS</b>	Load-Sensing-Controller This controller is designed for load sensing systems utilizing a suitable directional control valve.
<b>LSN</b>	Like coding LS, but with additional pressure limitation
<b>N</b>	Pressure controller, adjustable directly at the pump. Pressure controller automatically maintains a constant system pressure independent of the required flow. Therefore it is suited for constant pressure systems, where differing flow is required or as efficient pressure limitation of the hydraulic system.
<b>P</b>	Remotely adjustable pressure setting; the pressure is set with a pilot relief valve. The pilot relief can be positioned up to 20 m (60 ft) from the pump.
<b>Pb</b>	Like coding N, recommended only for systems with tendency to oscillations (accumulator systems). External lines are necessary.
<b>Q</b>	The flow compensator maintains a constant flow, with small power losses, in spite of variations in shaft speed and pressure. The flow is determined by the size of the flow restrictor (see the schematic on the right).
<b>Qb</b>	This is a special version of the Q compensator above. It has been developed to meet the accuracy and response requirements of hydrostatic transmission for generator drives and similar applications. The flow restrictor should be installed close to the pump in the main high pressure line. Pressure is sensed before and after the flow restrictor and connected to the compensator with two external lines. This provides increased control accuracy.
<b>V</b>	The controller V is used to control flow or speed in electronic or computer controlled systems. The V controller consists of a proportional solenoid acting on a servo valve that determines the position of the pump setting piston. The displacement of the pump is proportional to the current through the 24 V DC solenoid (about 250 - 750 mA). In order to minimize valve hysteresis, a pulse width modulated control signal of approx. 80-100 Hz frequency is recommended.
<b>VH</b>	The VH is a flow controller. It is similar to the V controller but the control signal is hydraulic. The required signal range is 7...32 bar (215...725 psi). The pump displacement is determined by the control signal (refer to the diagram). Pilot pressure can be supplied either from the system through a pressure reducing valve, or from an auxiliary pump. The pump should provide a pulsating flow of about 100 Hz; gear pump with 7 teeth and 750 rpm is recommended. If the system pressure is below 40...60 bar (580...870 psi) (depending on size) a small auxiliary pump is required to secure proper functioning of the controller.

**Table 3:** Flow pattern

Variable displacement axial piston pump with controller

Coding **L**

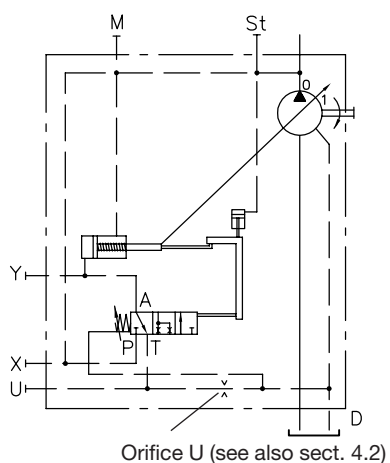

Coding **Lf1**

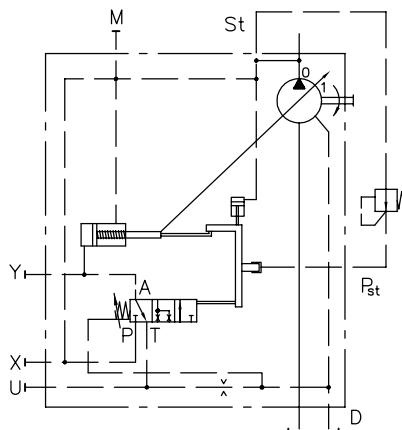

Coding **LS, LSN** 1)

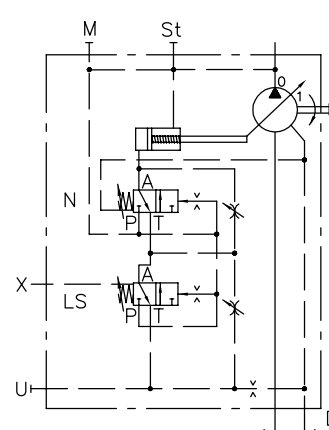

Coding **N**

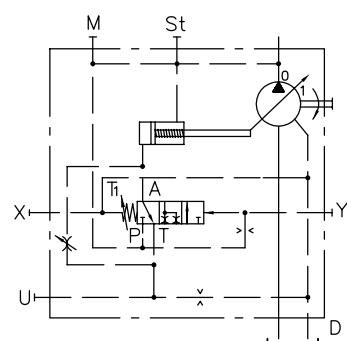

Coding **P**

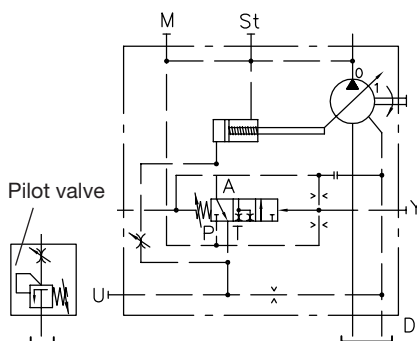

Coding **Pb**

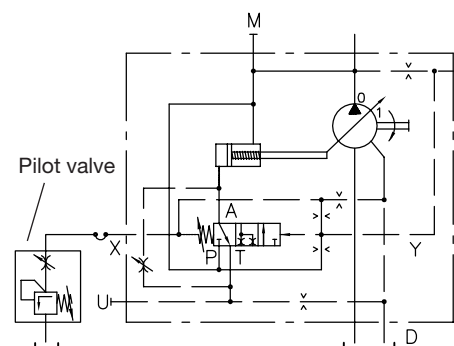

Coding **Q**

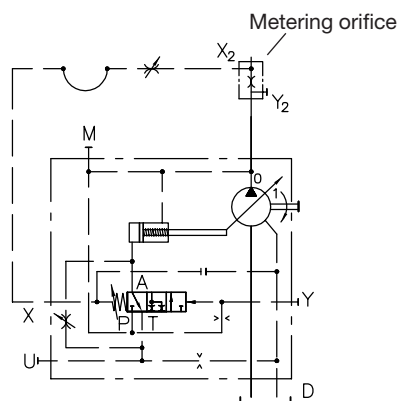

Coding **Qb**

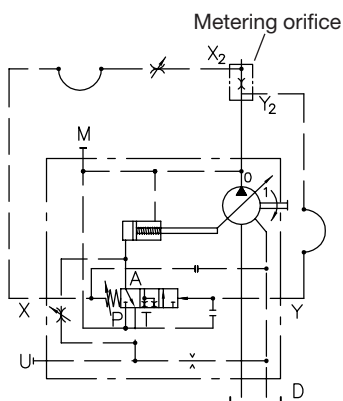

Coding **V**

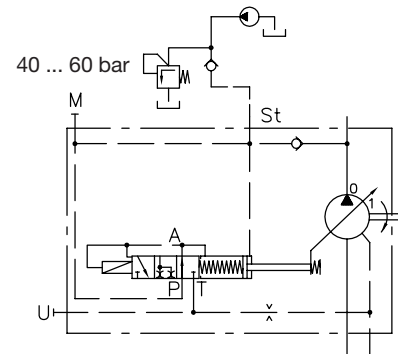

Coding **VH**

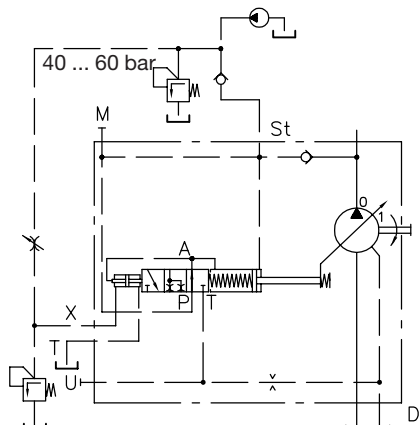

1) The pressure limiting valve „N“ is not available with type LS (version without pressure cut-off)

**Illustration controller range**

**Type V30D - 045 (075; 140; 160)**

(For position of controller for pumps type V30D-095 (115), see page 11!)

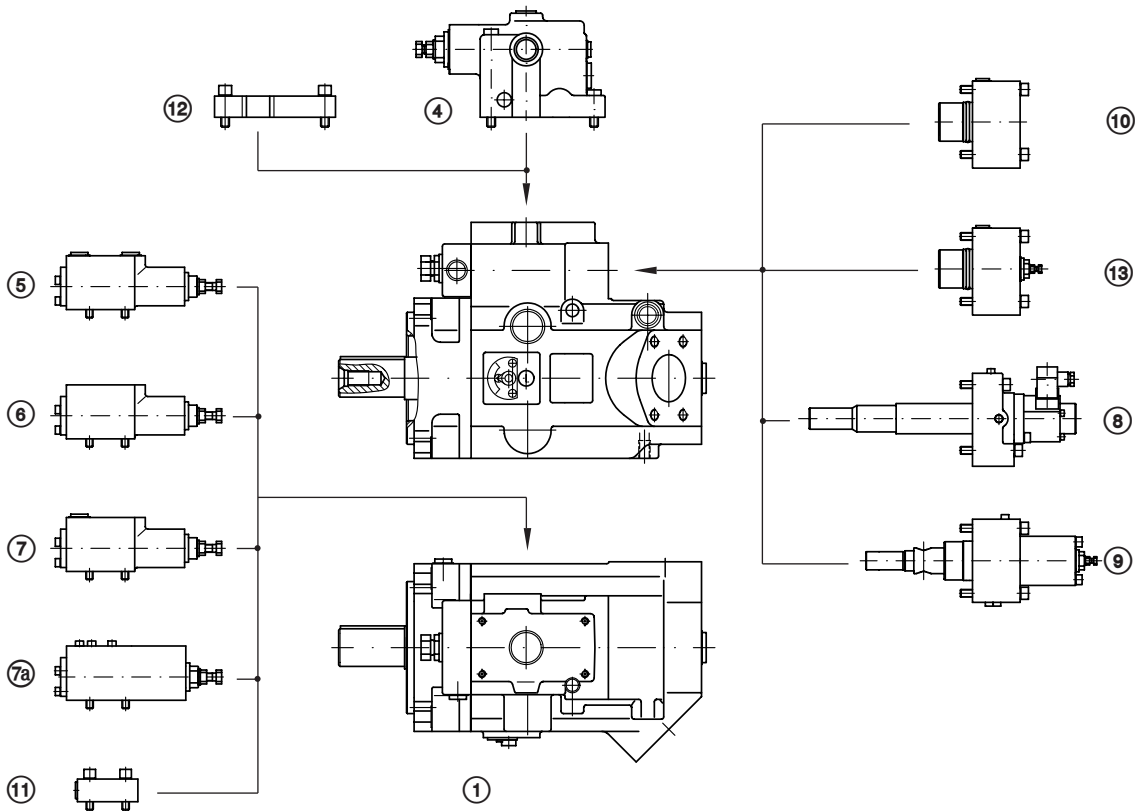

**Type V30D - 250**

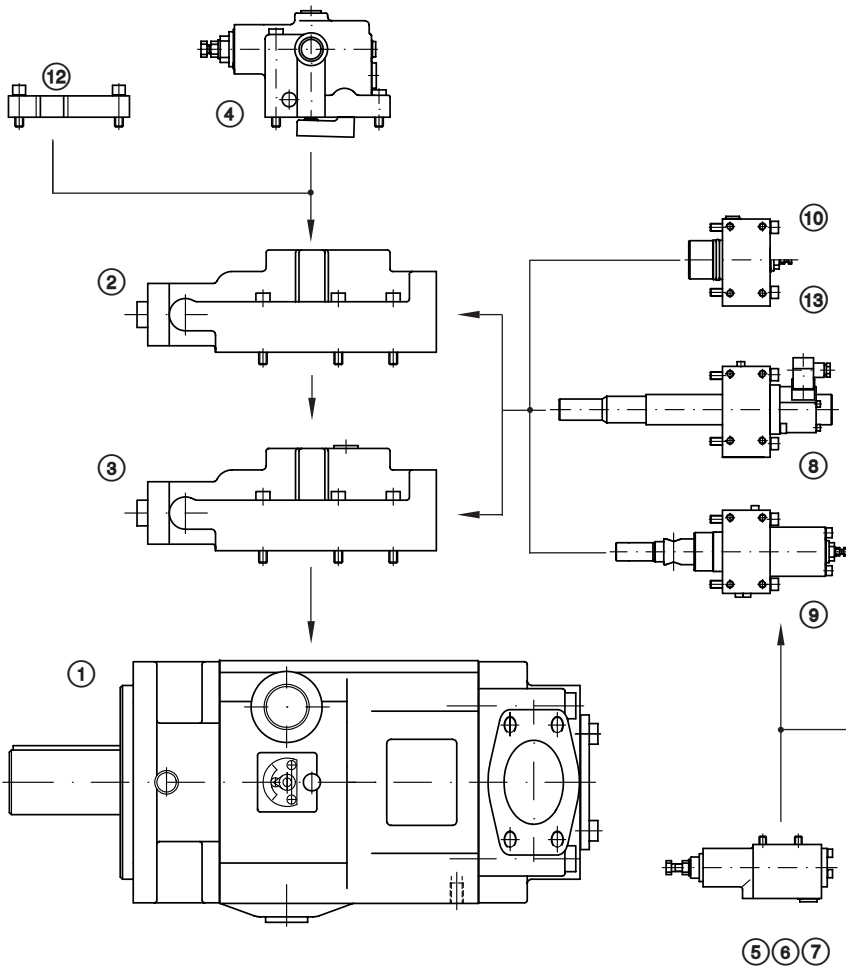

- ① Pump
- ② Adaptor for controller L
- ③ Adaptor for all other controllers (standard)
- ④ Controller L, LF1
- ⑤ Controller N
- ⑥ Controller Qb
- ⑦ Controller Q, P, LS
- ⑦a Controller LSN
- ⑧ Controller V
- ⑨ Controller VH
- ⑩ Blanking, when without V or VH
- ⑪ Blanking, when without N, P, Q, Qb, LS, LSN
- ⑫ Blanking, when without L
- ⑬ Blanking, when without V or VH but with stroke limitation

⑤ ⑥ ⑦      ⑦a      ⑪

### 3. Additional versions

#### 3.1 General

Working principle	Variable displacement axial piston pump acc. to swash plate principle
Installation	Flange or bracket mounting
Direction of rotation	Right hand or left hand
Mounting position	Optional
Pressure fluid	Hydraulic fluid (DIN 51524 table 2 and 3); ISO VG 10 to 68 (DIN 51519) Viscosity range: min. 10; max. 1000 mm <sup>2</sup> /s, optimal operation range: 10...35 mm <sup>2</sup> /s Also suitable are biodegradable pressure fluids of the type HEES (synth. Ester) at operation temperatures up to +70°C.
Temperatur	Ambient: -40 ... +60°C Fluid: -25...+80°C, pay attention to the viscosity range! Start temperature down to -40°C are allowable (Pay attention to the viscosity range during start!), as long as the operation temperature during consequent running is at least 20K (Kelvin) higher.
Filtration	Should conform to ISO standard 4406 coding 18/13.
Start-up	All hydraulic lines should be flushed with appropriate hydraulic fluid before start-up. The pump case should then be tilted through the uppermost drain port. The drain line must be positioned so that the case is always filled during operation. At start-up and during the first few minutes of the operation the pressure relief valve should be adjusted to 50 bar (700 psi) or less.

Designation		045	075	095	115	140	160	250
Max. swash plate angle	[°]	17	17.5	17	20	17.5	20	17.5
Min. inlet pressure (absolute), open circuit	bar (psi)	0.85 12	0.85 12	0.85 12	0.85 12	0.85 12	0.85 12	0.85 12
Self-priming speed at max swash plate angle and 1 bar (15 psi) absolute inlet pressure	rpm	2600	2400	2200	2000	2200	1900	1800 <sup>2)</sup>
Max. speed (requires increased inlet pressure)	rpm	3600	3200	2900	2800	2600	2500	2000
Min. continuous speed	rpm	500	500	500	500	500	500	500
Torque (theor.) at 1000 psi	Nm (lbf ft)	71 35	119 61	153 78	185 93	226 115	261 132	414 203
Input power at 250 bar and 1450 rpm at 3000 psi and 1800 rpm	kW (hp)	30 41	50 68	64 87	77 105	95 129	109 148	174 237
Weight (approx. kg) without controller (approx. lbs)		40 88	60 132	70 154	70 154	85 187	85 187	130 287
(approx. kg) with controller (approx. lbs)		46 101	66 145	76 168	76 168	91 201	91 201	136 300
Moment of inertia	kg m <sup>2</sup> (ft. lbs. sec <sup>2</sup> )	0.0056 0.0041	0.0124 0.0092	0.0216 0.016	0.0216 0.016	0.03 0.022	0.03 0.022	0.0825 0.061
L10 bearing life at 250bar (1450 rpm) or 3600 psi (1800 rpm) and max. displacement	(h) (h)	31000 25000	20000 16000	17000 14000	10000 8000	17000 14000	10000 8000	23000 19000
Max. dynamic torque								
Spline shaft (D) input	Nm (lbf ft)	550 405	910 670	1200 885	1200 885	1700 1250	1700	3100 2285
Spline shaft (D) output	Nm (lbf ft)	275 205	455 333	600 445	600 445	850 625	850	1550 1145
Key shaft (K) input	Nm (lbf ft)	280 205	460 340	650 480	650 480	850 630	850 630	1550 1145
Spline shaft (S) input	Nm (lbf ft)	500 370	500 370	1200 885	1200 885	1200 885	1200 885	1200 885
Spline shaft (S) output <sup>1)</sup>	Nm (lbf ft)	275 205	455 335	600 445	600 445	850 625	850 625	1000 740
Noise level at 250 bar and (1450 rpm), or 3600 psi and max. (1800 rpm) displacement (measured in a semi-anechoic room according to ISO 4412 measuring distance 1m)	(dB(A)) (dB(A))	72 75	74 78	75 79	75 79	76 80	76 80	77 82

1) (theoretical) Drive torque must not be exceeded

2) The max. geometric displacement of 260 cm<sup>3</sup>/rev can only be achieved up to a self sucking speed of 1600 rpm

### 3.2 Curves

#### 3.2.1 Flow and Power (basic pump)

The following diagrams show max. delivered flow vs. pressure (without controller).

Required input power at max. swash angle and required input power when the pump is operating at „idling“. Shaft speed: 1450 rpm

**Type V30D - 045**

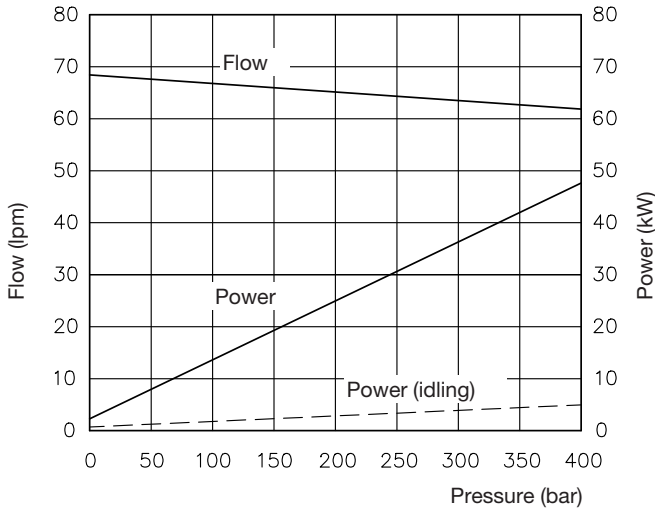

**Type V30D - 075**

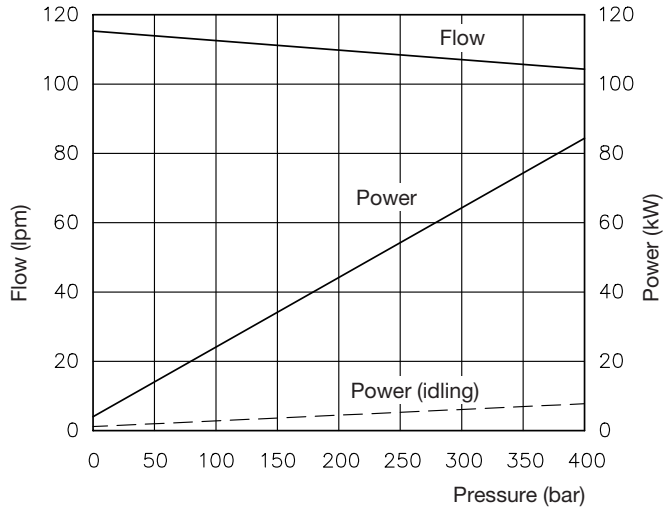

**Type V30D - 095 (115)**

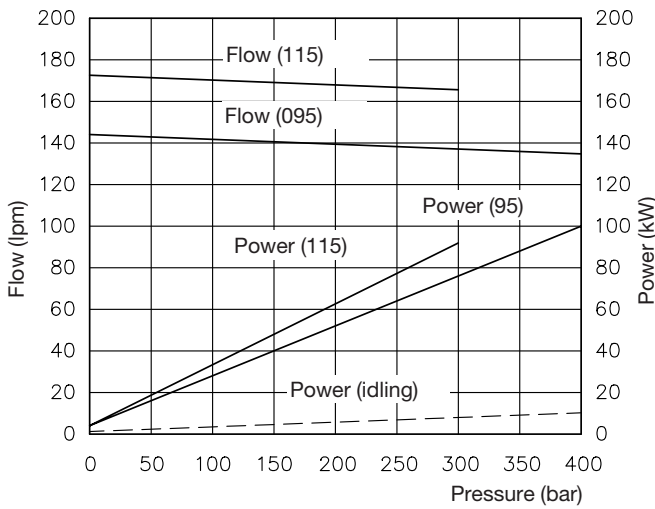

**Type V30D - 140 (160)**

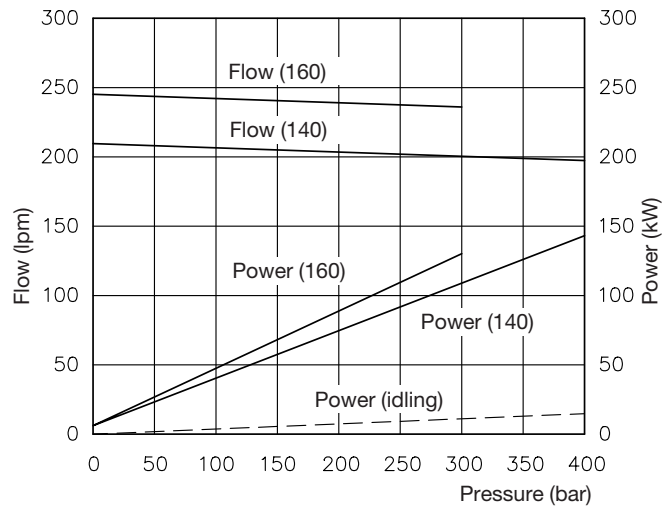

**Type V30D - 250**

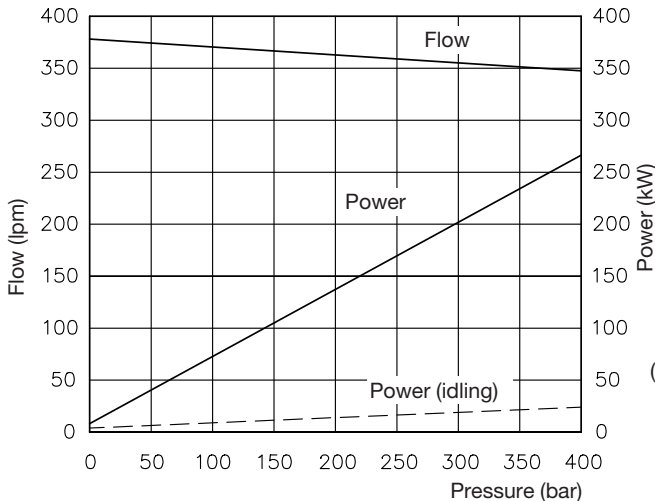

#### Inlet pressure

To avoid cavitation, it is essential to ensure that the pump inlet pressure always exceeds the min pressure shown in the diagram above. The diagram is valid for viscosities up to 75 mm<sup>2</sup>/s at max. swash plate angle

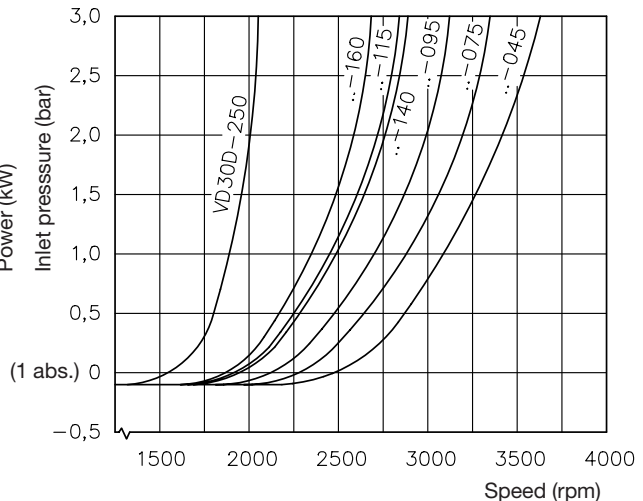

### 3.2.2 Controller-curves

Coding | Curves, notes

**L**  
**Lf1**  
**Lf1**

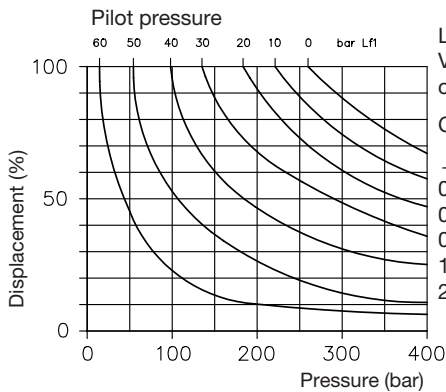
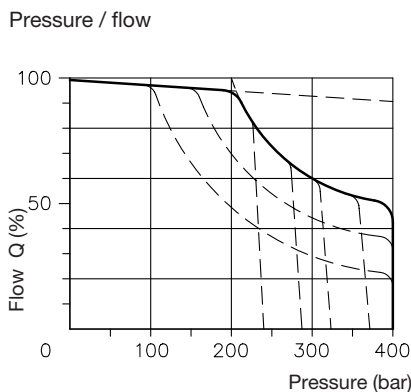

Lowest recommended torque setting:  
Valid only for version with power controller without additional combination

Coding	Nm (lbf ft)	Power kW/rpm (hp/rpm)
045	40 (29.5)	6 /1500 (10/1800)
075	70 (51.6)	11/1500 (18/1800)
095/115	99 (73.0)	15/1500 (25/1800)
140/160	146 (107.7)	22/1500 (37/1800)
250	271 (199.8)	41/1500 (69/1800)

**N**  
**P**  
**Pb**

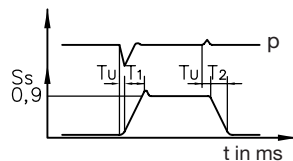
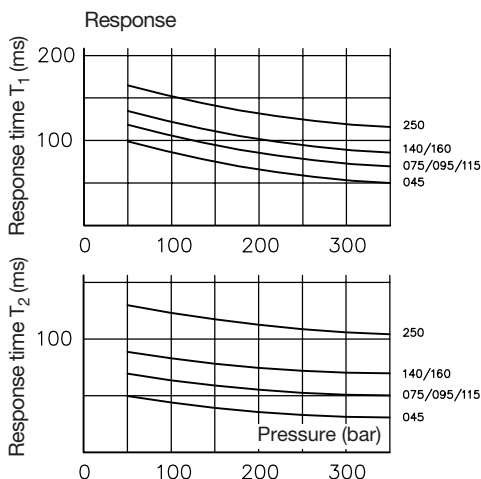
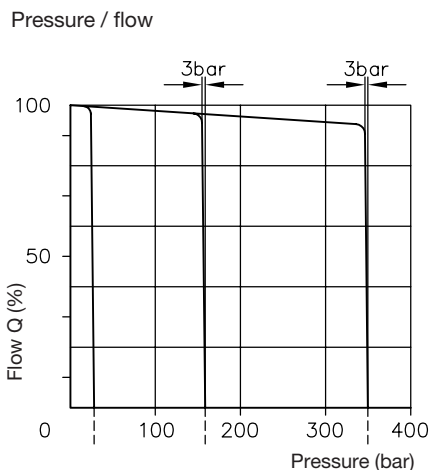

$S_s$  = Displacement  
 $T_u$  = Delay < 3 ms  
 $T_1$  = Response time min to max  
 $T_2$  = Response time max to min  
 $p$  = Pressure for hydraulic capacity 0.15 cm<sup>3</sup>/bar (1.5 m pipe nom. dia. 20 mm)

**Q**  
**Qb**  
**LS**

Calculation of flow Q:  
 $Q = C \cdot A \sqrt{\Delta p}$  (lpm)  
 $A$  = Size of orifice (mm<sup>2</sup>)  
 $\Delta p$  = Pressure drop = 10 bar (LS = 30 bar) = 145 psi (LS = 435 psi)  
 $C = 0.6$   
 Characteristics:  
 Accuracy with max. flow:  
 a) Speed "n" constant, pressure varying between 30 and 350 bar, (430 and 3600 psi): (< 3%)  
 b) Pressure "p" constant, speed varying (< 1%)

Speed constant

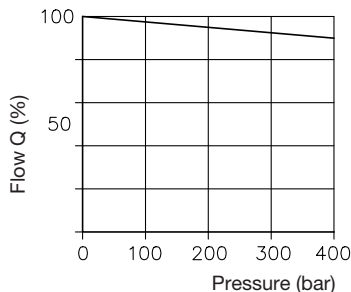

Speed varying

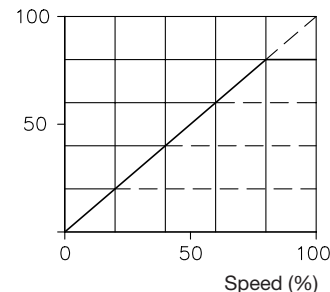

**V**  
**VH**

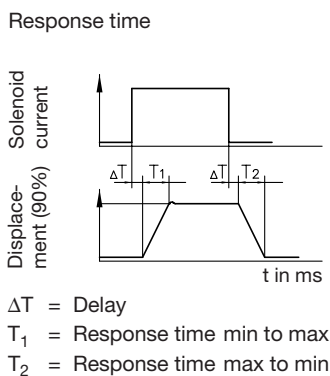
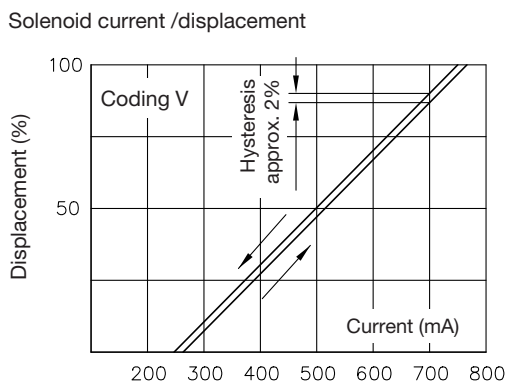

Signal pressure/displacement

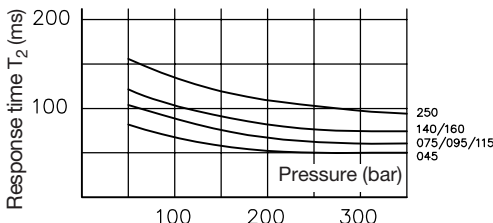
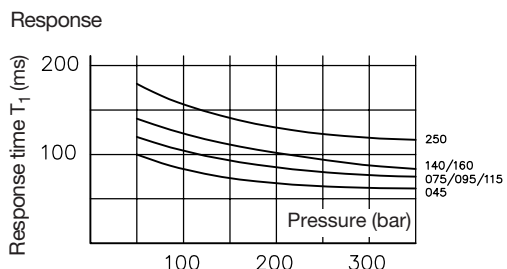
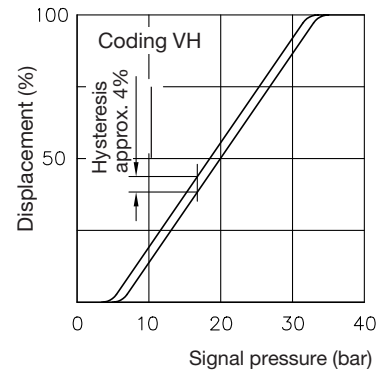



## 4. Unit dimensions All dimensions in mm, (inch) and subject to change without notice!

### 4.1 Basic pump

**Type V30D - 045** (Drawings shows clockwise rotation, ports A and B are located different with anti clockwise rotation, see foot note 1))

Measuring port G 1/4      Drain port (D<sub>1</sub>, D<sub>2</sub>) G 1/2      Auxiliary pump conn. G 1/4

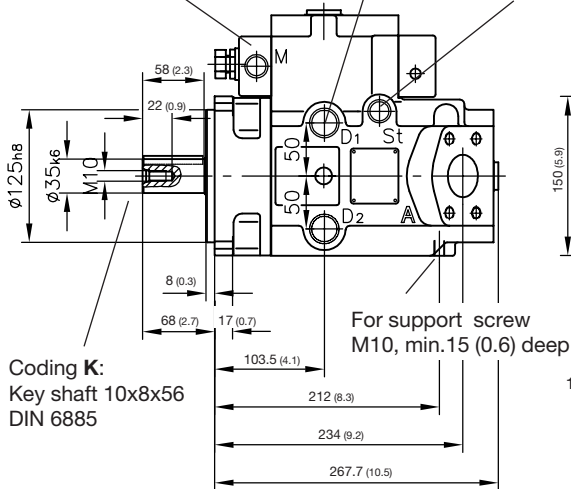

**Coding K:**  
Key shaft 10x8x56  
DIN 6885

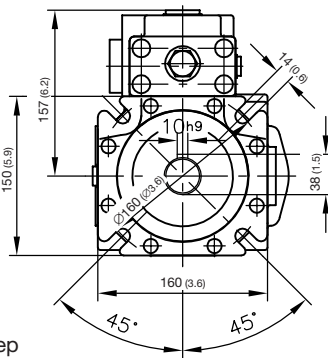

- 1) Clockwise rotation:  
A = Suction SAE 1 1/2" (3000 psi)  
B = Pressure SAE 3/4" (6000 psi)
- Anti clockwise rotation:  
A = Pressure SAE 3/4" (6000 psi)  
B = Suction SAE 1 1/2" (3000 psi)

For support screw  
M10, min.15 (0.6) deep

**View X:**

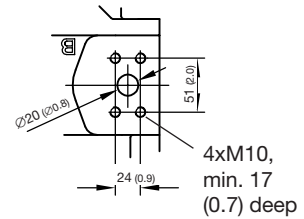

**View U:**

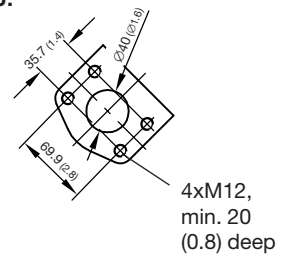

Breather G 1/4

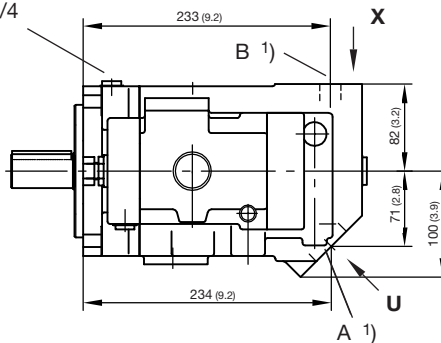

**Coding D:**  
Spline shaft  
W35x2x16x9g  
DIN 5480

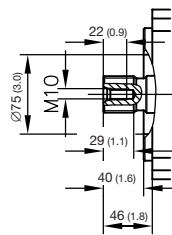

**Coding S:**  
Spline shaft SAE - C  
14T - 12/24 DP  
Flat Root Side Fit  
For flange, see foot note 1) page 12

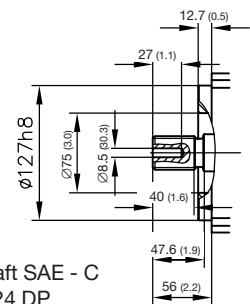

**Type V30D - 075** (Drawings shows clockwise rotation, ports A and B are located different with anti clockwise rotation, see foot note 1))

Measuring port G 1/4      Drain port (D<sub>1</sub>, D<sub>2</sub>) G 3/4      Auxiliary pump conn. G 1/4

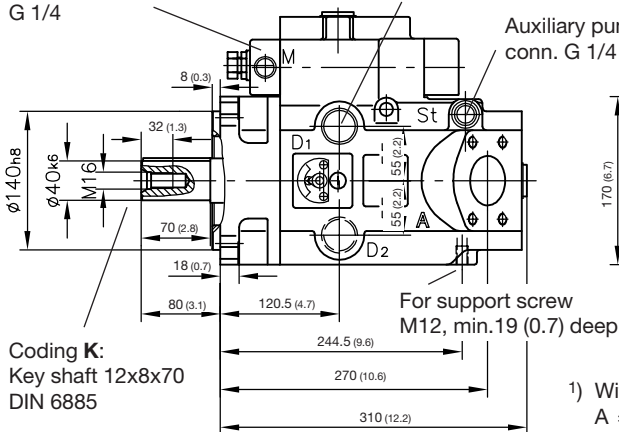

**Coding K:**  
Key shaft 12x8x70  
DIN 6885

- 1) With right-hand rotation:  
A = Suction SAE 2" (3000 psi)  
B = Pressure SAE 1" (6000 psi)
- Anti clockwise rotation:  
A = Pressure SAE 1" (6000 psi)  
B = Suction SAE 2" (3000 psi)

For support screw  
M12, min.19 (0.7) deep

**View X:**

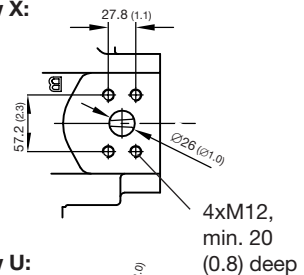

**View U:**

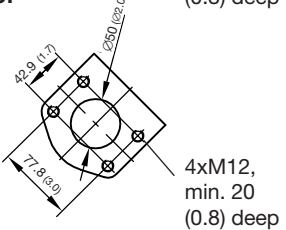

Breather G 1/4

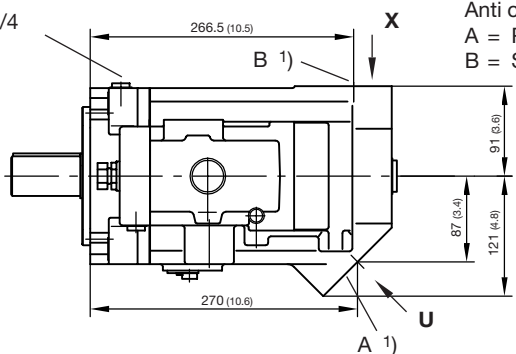

**Coding D:**  
Spline shaft  
W40x2x18x9g  
DIN 5480

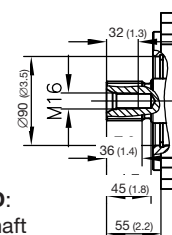

**Coding S:**  
Spline shaft SAE - C  
14T - 12/24 DP  
Flat Root Side Fit  
For flange, see foot note 1) page 12

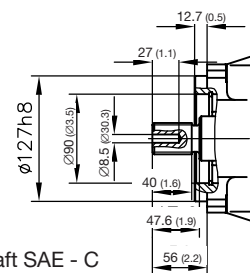



**Type V30D - 095 (115)** (Drawings shows clockwise rotation, ports A and B are located different with anti clockwise rotation, see foot note 1))

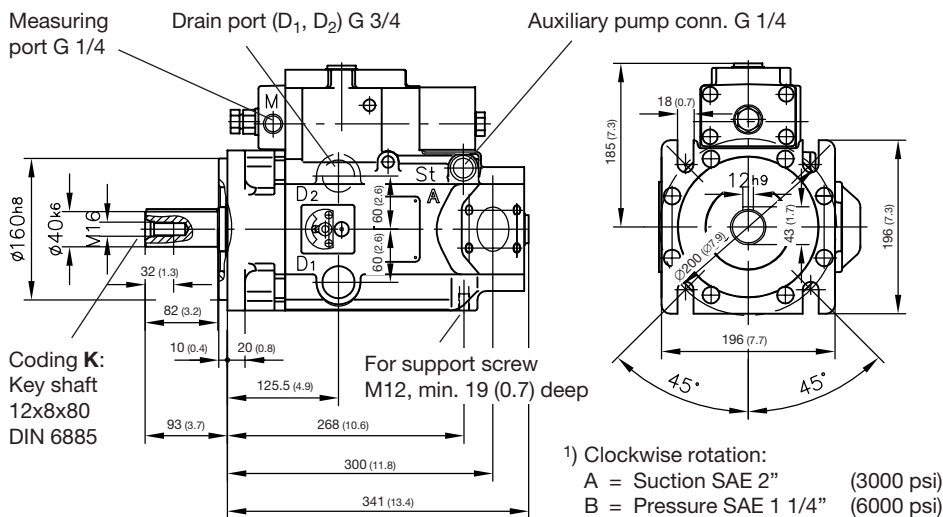

All dimensions in mm, (inch) and subject to change without notice!  
 (G = BSPP)

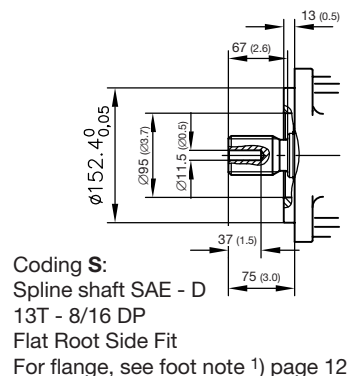
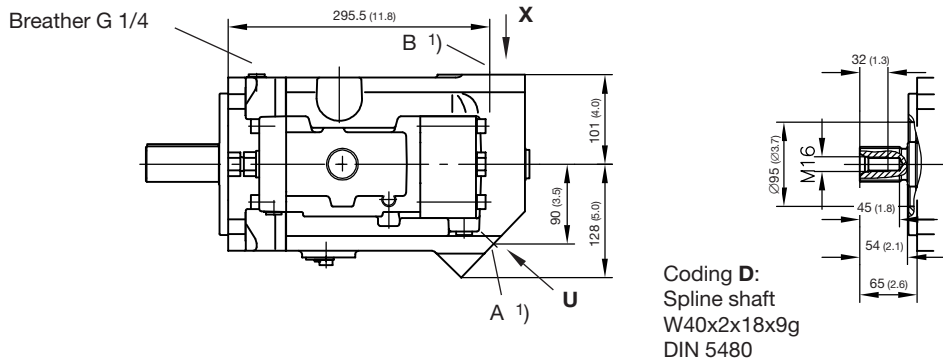
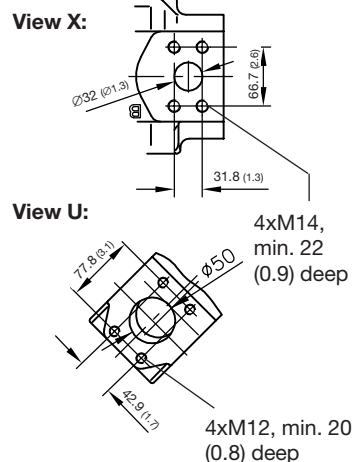

**Type V30D - 140 (160)** (Drawings shows clockwise rotation, ports A and B are located different with anti clockwise rotation, see foot note 1))

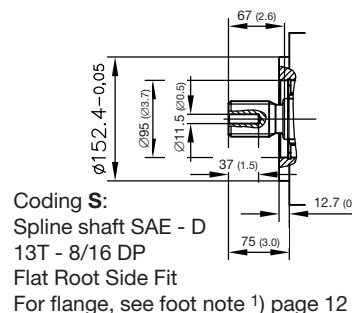
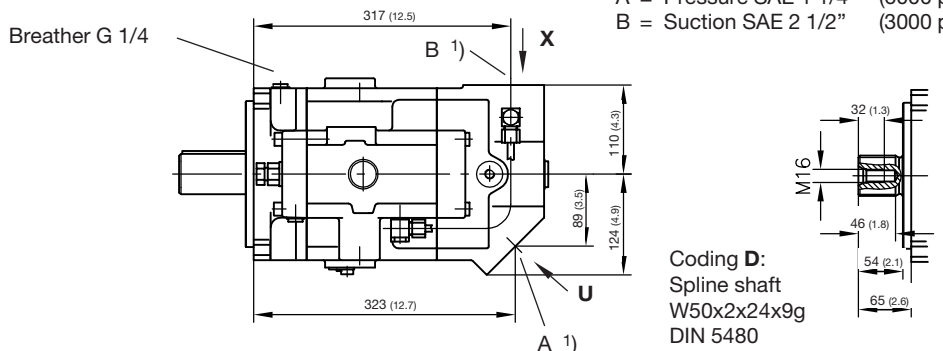
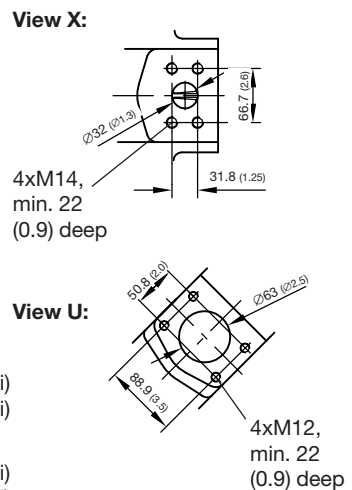
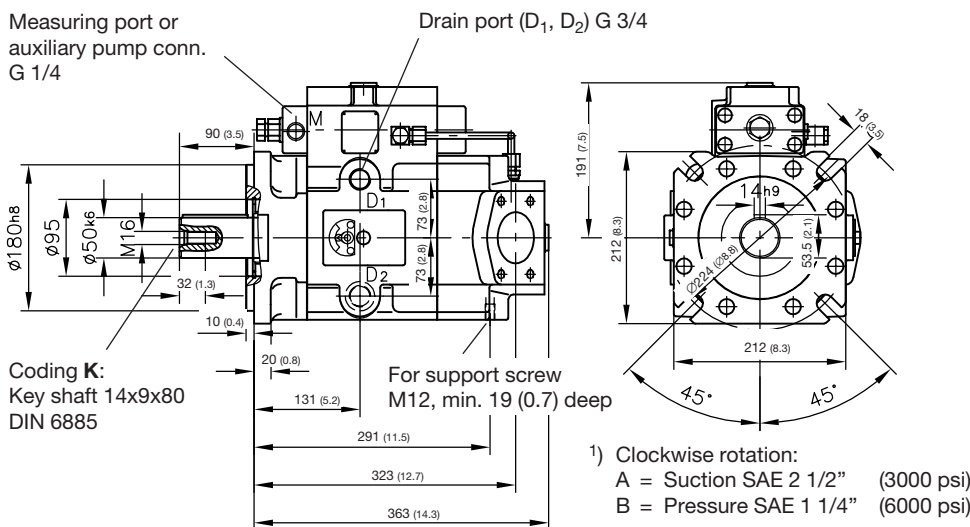

**Type V30D - 250** (Drawings shows clockwise rotation, ports A and B are located different with anti clockwise rotation, see foot note 1 )

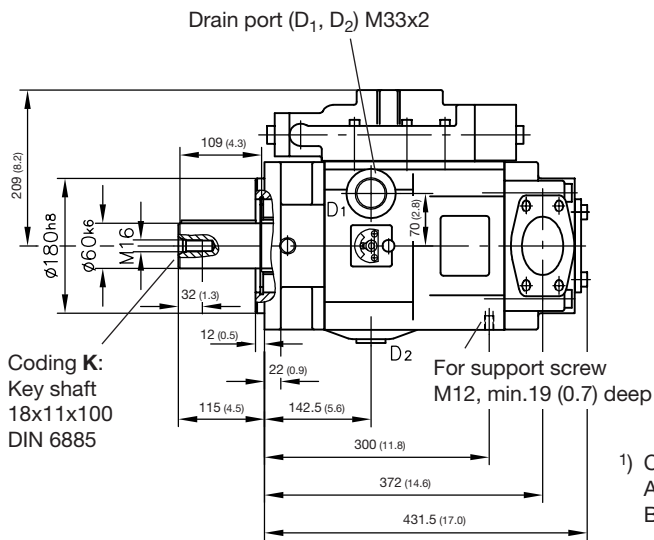

All dimensions in mm, (inch) and subject to change without notice!

(G = BSPP)

**View X:**

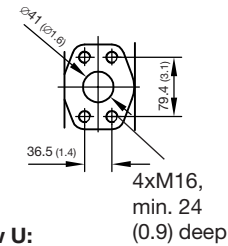

**View U:**

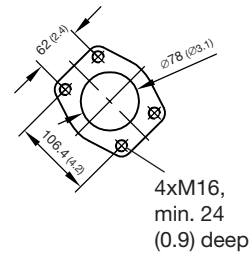

- 1) Clockwise rotation:  
 A = Suction port SAE 3" (3000 psi)  
 B = Pressure port SAE 1 1/2" (6000 psi)
- Anti clockwise rotation:  
 A = Pressure port SAE 1 1/2" (6000 psi)  
 B = Suction port SAE 3" (3000 psi)

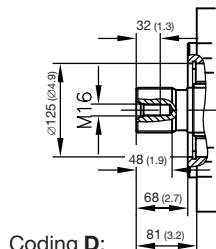
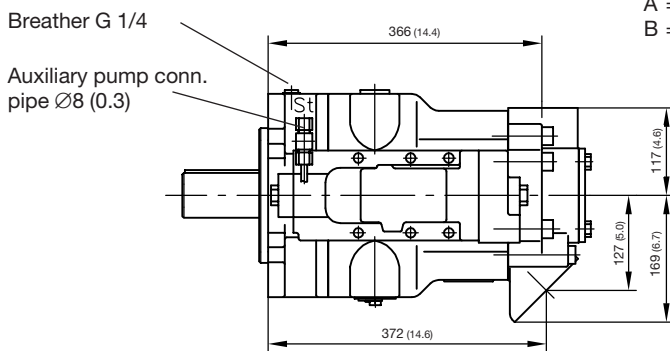

**Coding D:**  
 Spline shaft  
 W60x2x28x9g  
 DIN 5480

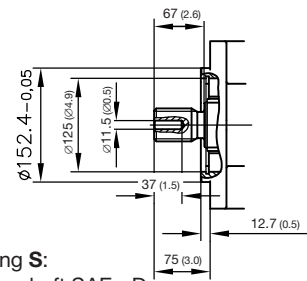

**Coding S:**  
 Spline shaft SAE - D  
 13T - 8/16 DP  
 Flat Root Side Fit  
 For flange, see foot note 1) page 12

**4.2 Controller**

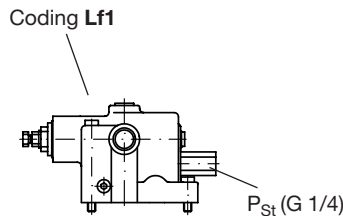
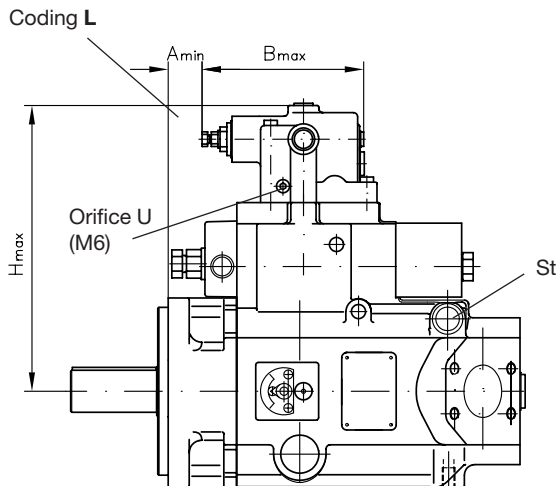

(G = BSPP)

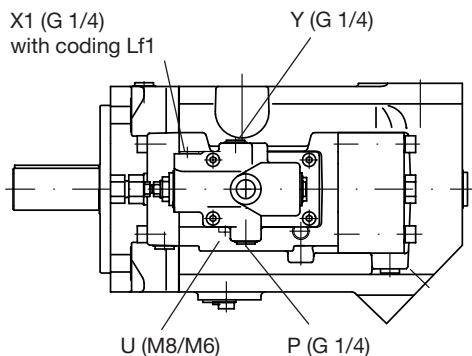

For missing dimensions, see basic pump sect. 4.1!

Basic type	A	B	H
	mm (in)	mm (in)	mm (in)
045	3.5 (0.14)	159 (6.26)	247 (9.7)
075	14.5 (0.57)	169 (6.65)	258 (10.2)
095/115	18.5 (0.73)	169 (6.65)	262 (10.3)
140/160	24.5 (0.96)	169 (6.65)	278 (10.9)
250	55.5 (2.19)	169 (6.65)	293 (11.5)

Coding N, P, Pb, Q, Qb, LS and LSN

Type V30D - 045  
V30D - 075  
V30D - 140/160

(G = BSPP)

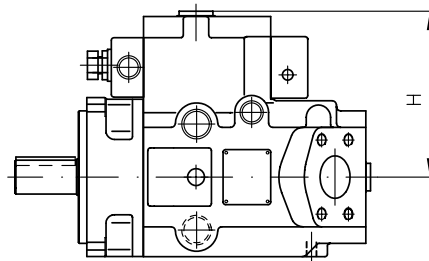
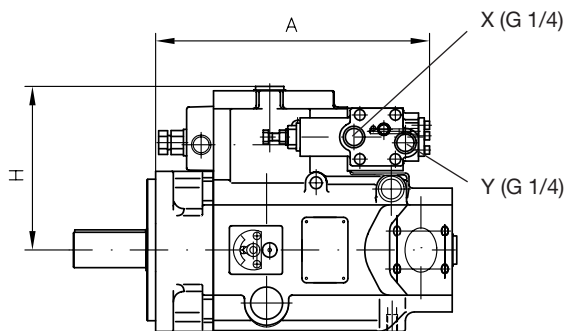

Location of orifice U (M6) <sup>1)</sup> at type V30D-095/115 (in the pump housing) at type V30D-250 (in the blanking plate)

For missing dimensions, see basic pump sect. 4.1!

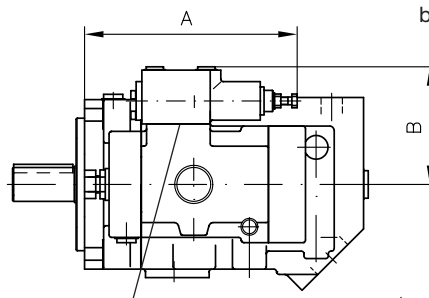
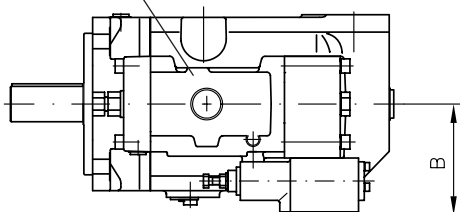

Orifice U (M6) below controller <sup>1)</sup>

	A	H	B
Basic type	mm (in)	mm (in)	mm (in)
045	208(8.19)	157(6.18)	117(4.60)
075	224(8.82)	171(6.73)	117(4.60)
095/115	307(12.1)	185(7.28)	120(4.72)
140/160	240(9.44)	191(7.52)	118(4.64)
250	365(14.4)	209(8.23)	122(4.80)

<sup>1)</sup> at version without power controller

Coding V

Coding VH

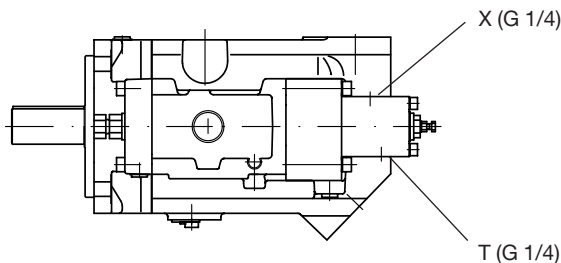
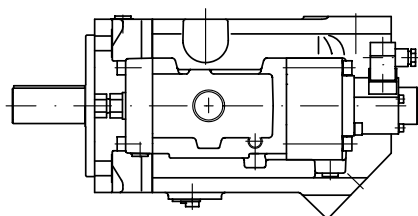
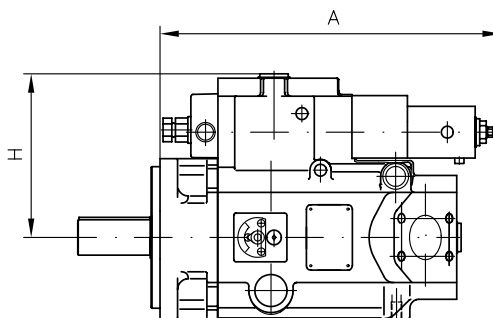
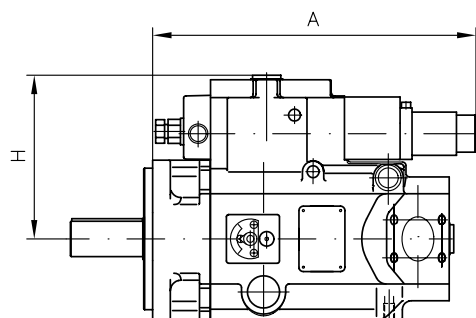

	A	H
Basic type	mm (in)	mm (in)
045	319(12.56)	157(6.18)
075	351(13.82)	171(6.73)
095/115	362(14.25)	185(7.28)
140/160	371(14.61)	191(7.52)
250	419(16.49)	209(8.22)

	A	H
Basic type	mm (in)	mm (in)
045	338(13.31)	157(6.18)
075	371(14.65)	171(6.73)
095/115	381(15.00)	185(7.28)
140/160	390(15.35)	191(7.52)
250	438(17.24)	209(8.22)

For missing dimensions, see basic pump sect. 4.1!

## 5. Tandem pumps

Two variable displacement axial piston pumps can be linked via an intermediate flange. Available are shaft design "D" and "S". Same controller range as for individual pumps.

Order example:

V30D - 140 RDN-2-1-XX/LLSN -2/120 - 200 - V30D - 140 RDN-1-1-XX/LLSN -2/120 - 200  
 (1. pump) (2. pump)

(For type coding key, see sect. 2)

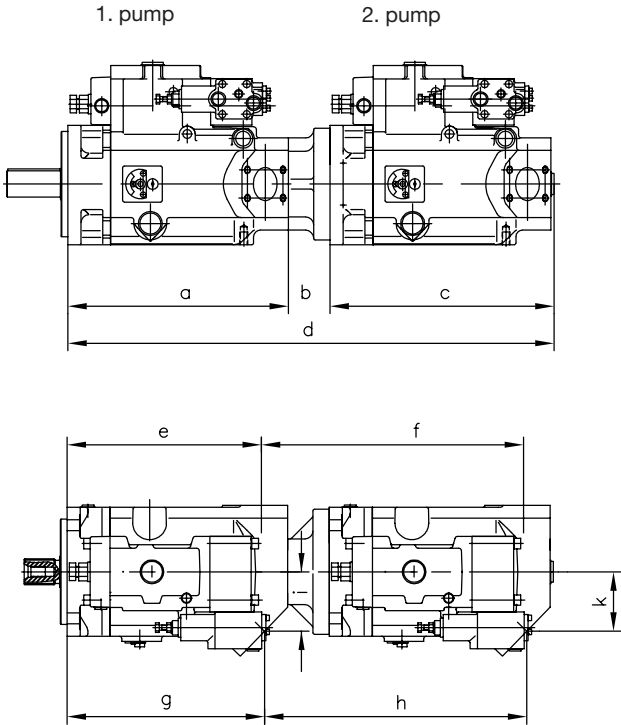

1. pump 2. pump	V30D-045									
	a	b	c	d	e	f	g	h	i	k
V30D-045	263	62	268	593	233	325	234	325	71	71
	V30D-075									
	a	b	c	d	e	f	g	h	i	k
V30D-045	305	63	268	636	267	334	270	332	87	71
V30D-075	305	63	310	678	267	368	270	368	87	87
	V30D-140 (160)									
	a	b	c	d	e	f	g	h	i	k
V30D-045	358	63	268	689	317	337	323	332	89	71
V30D-075	358	63	310	731	317	371	323	368	89	87
V30D-095 (115)	358	63	341	762	317	400	323	398	89	90
V30D-140 (160)	358	84	363	805	317	442	323	442	89	89
	V30D-095 (115)									
	a	b	c	d	e	f	g	h	i	k
V30D-045	336	63	268	667	296	336	300	333	90	71
V30D-075	336	63	310	709	296	369	300	369	90	87
V30D-095 (115)	336	63	341	740	296	399	300	399	90	90
	V30D-250									
	a	b	c	d	e	f	g	h	i	k
V30D-045	415	60	268	743	366	342	372	337	127	71
V30D-075	415	60	310	785	366	376	372	373	127	87
V30D-095 (115)	415	75	341	831	366	420	372	418	127	90
V30D-140 (160)	415	87	363	865	366	453	372	453	127	89
V30D-250	415	87	431	933	366	502	372	502	127	127

There are additionally several other combination possibilities via the SAE-flange. This enables direct connection of an auxiliary pump (e.g. gear pump).

Order example:

V30D - 140 RSN -2-1-XX/LN - 2 /120 - 200 - **SAE-C/4**

Combination possibilities and dimensions (dimension b acc. to above illustration)

	SAE-A	SAE-B/2	SAE-B/4	SAE-C/2	SAE-C/4	SAE-D
V30D - 045	36	62	62	--	--	--
V30D - 075	31.5	52	52	83.5	63	--
V30D - 095 (115)	24	52	52	83.5	63	73
V30D - 140 (160)	30.5	52	52	83.5	63	73
V30D - 250	38	52	52	66	66	81.5
Dimension m	106.4	146	89.8	181	114.5	161.9
n	2xM10	2xM12	4xM12	2xM16	4xM12	4xM16

**Metric conversions:**

- 1 psi = 0.0689 bar
- 1 cu in = 16.387 cm<sup>3</sup>
- 1 lbf ft = 1.3562 Nm
- 1 US gal = 3.7854 l
- 1 lb = 0.454 kg
- 1 in = 25.4 mm
- 1 hp = 0.745 kW
- 1 ft<sup>2</sup> = 1.3558 m<sup>2</sup>

Flange  
SAE-A  
SAE-B/2  
SAE-C/2

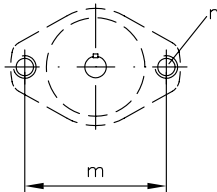

Flange  
SAE-B/4  
SAE-C/4  
SAE-D

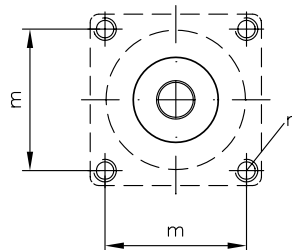

1) Notes to version with shaft end coding **S**  
 The SAE-flanges on the drive side feature thru-holes instead of threads n