

Variable displacement axial piston pump type V60N

Product documentation

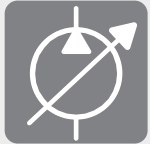

Open circuit,
for the power take-off of commercial vehicles

Nominal pressure $p_{\text{nom max}}$: 400 bar

Peak pressure p_{max} : 450 bar

Geometric displacement V_{max} : 130 cm³/rev

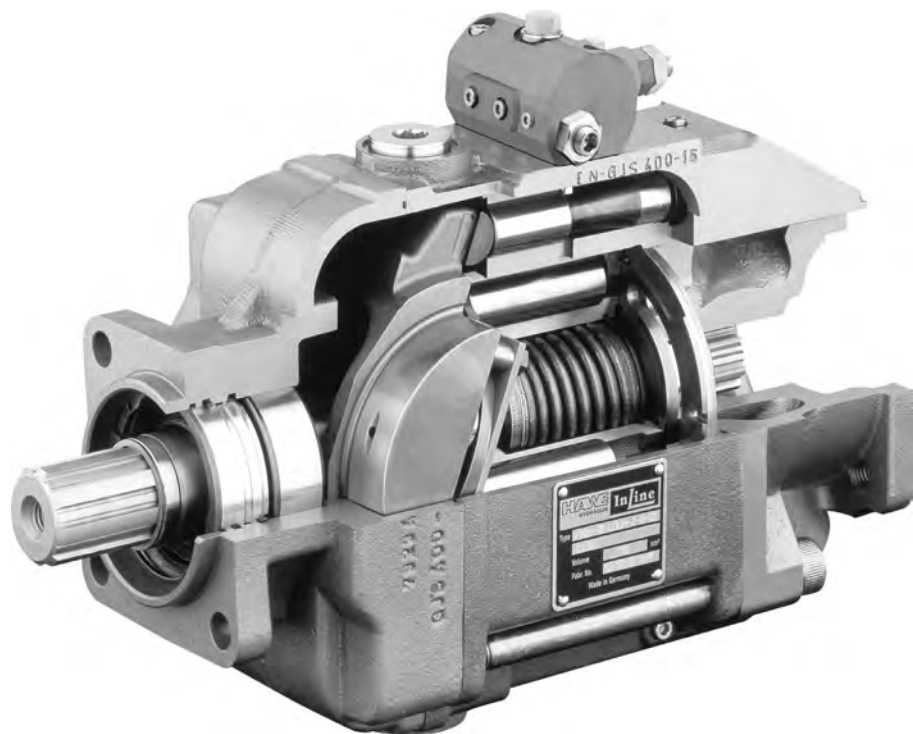

© by HAWE Hydraulik SE.

The forwarding and reproduction of this document, as well as the use and communication of its contents, are forbidden unless expressly permitted.

Any breach or infringement will result in liability for damages.

All rights reserved concerning patent or utility model registrations.

Contents

1	Overview: variable displacement axial piston pump types V60N.....	4
2	Available versions, main data.....	5
2.1	Basic version.....	5
2.2	Controller switching symbols.....	12
3	Parameters.....	15
3.1	General.....	15
3.2	Planning information for parameters.....	17
3.3	Characteristic curves.....	18
3.4	Controller characteristic curves.....	19
4	Dimensions.....	21
4.1	Basic pump.....	21
4.1.1	Type V60N-060.....	21
4.1.2	Type V60N-090.....	26
4.1.3	Type V60N-110.....	31
4.1.4	Type V60N-130.....	36
4.2	Controllers and intermediate plates.....	40
5	Installation information.....	43
5.1	General information.....	43
5.2	Ports.....	44
5.3	Installation positions.....	45
5.4	Tank installation.....	46
6	Installation, operation and maintenance information.....	47
6.1	Designated use.....	47
6.2	Assembly information.....	47
6.3	Operating instructions.....	47
7	Accessories, spare parts and separate components.....	48
7.1	Discontinued controller units.....	48
7.1.1	Available versions.....	48
7.2	Suction intakes.....	50
7.3	Coupling flange for propshafts.....	51

1 Overview: variable displacement axial piston pump types V60N

Variable displacement axial piston pumps operate according to the bent axis principle. They adjust the geometric delivery volume from maximum to zero. As a result they vary the volumetric flow that is provided to the loads.

The axial piston pump type V60N is designed for open circuits in mobile hydraulics and works according to the swash plate principle. It is available with the option of a thru-shaft for operating additional hydraulic pumps in series. The pump is fitted above all to the power take-off on commercial vehicle transmissions. The range of pump controllers allows the axial piston pump to be used in a variety of applications.

Features and benefits:

- Optimized power-to-weight ratio
- High self-suction speed
- Wide range of controllers

Intended applications:

- Municipal trucks
- Cranes and lifting equipment
- Machines for forestry and agricultural purposes
- Truck-mounted concrete pumps

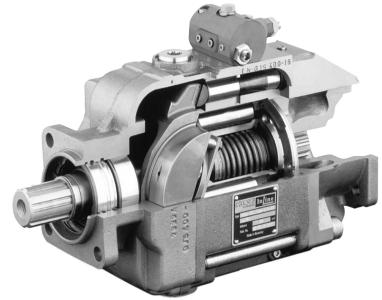

Figure 1: Variable displacement axial piston pump type V60N-110



Figure 2: Variable displacement axial piston pump type V60-130

2 Available versions, main data

2.1 Basic version

Circuit symbol:



Order coding example:

V60N	-090	R	D	Z	N	- 2	-0	03	/LSNR/ZL	- 2/65	- 350	-	A00/76	- C 022
														Flange version Table 13 Flange versions (output side)
														Suction intakes Suction intakes: see Section Chapter 7, "Accessories, spare parts and separate components"
														Ports Table 12 Ports
														Pressure specification (bar)
														Stroke limitation Table 11 Stroke limitations
														Controller Table 8 Controllers; Table 9 Intermediate plates; Table 10 Solenoid voltage and versions
														Release
														Additional function Table 7 Additional function
														Housing version Table 6 Housing versions
														Seal Table 5 Seals
														Flange version Table 4 Flange versions (input side)
														Shaft version Table 3 Shaft versions
														Rotating direction Table 2 Rotating directions
														Nominal size Table 1 Nominal sizes
														Basic type

Table 1: Nominal size

Coding	Geometric displacement (cm ³ /rev)	Nominal pressure p _{nom} (bar)	Peak pressure p _{max} (bar)
060	60	350	400
090	90	350	400
110	110	350	400
130	130	400	450

Table 2: Rotating directions

Coding	Description
L	Anti-clockwise
R	Clockwise

When looking at the shaft journal

(for information on change of rotating direction, see [Chapter 3, "Parameters"](#))

Table 3 Shaft versions

Coding	Description	Designation/Standard	Max. drive torque (Nm)
D	Parallel key splined shaft	Similar to DIN ISO 14 (trucks)	800
M	Spline shaft	DIN 5480 (only V60N-090, V60N-110)	530
H	Spline shaft	SAE-B J 744 13T 16/32 DP 22-4 ISO 3019-1 (only V60N-060)	210
U	Spline shaft	SAE-B J 744 short 13T 16/32 DP 22-4 ISO 3019-1 short (only V60N-060)	210
T	Spline shaft	SAE-BB J 744 15T 16/32 DP 25-4 ISO 3019-1 (only V60N-060)	340
S	Spline shaft	SAE-C J 744 14T 12/24 DP 32-4 ISO 3019-1	640
Q	Spline shaft	SAE-CS 21T 16/32 DP 35-4 ISO 3019-1 (only V60N-090, V60N-110, V60N-130)	900

Table 4 Flange versions (input side)

Coding	Description	Designation
Y	Flange	ISO 7653-1985 (for trucks)
P	Flange	ISO 7653-1985 10° rotated (for trucks) (only V60N-110, V60N-130) ¹⁾
X	Flange	SAE-B 2-hole J 744 - 45° rotated 101-2 ISO 3019-1 (only V60N-060)
Z	Flange	SAE-B 4-hole J 744 101-4 ISO 3019-1 (only V60N-060)
F	Flange	SAE-C 4-hole J 744 127-4 ISO 3019-1
G	Flange	125 B4 HW ISO 3019-2 (only V60N-090)

Table 5 Seals

Coding	Description
N	NBR
V	FKM

Table 6 Housing versions

Coding	Description
1	Suction and pressure port axial
2	Suction and pressure port radial, with thru-shaft
3	Suction and pressure port radial
4	Suction and pressure port axial, ports SAE J 518 (only V60N-090)

Table 7 Additional functions

Coding	Description
0	None

¹⁾ For narrow installation spaces, e.g. Mercedes Benz NA 124 gear manufacturing

Table 8 Controllers

Coding	Description																																				
LSNR	<p>Load-sensing controller with integrated pressure limitation.</p> <p>The LSNR controller is a delivery flow controller that generates a variable volumetric flow independently of the rotation speed. It sets a constant difference between the load pressure and pump pressure by continuously adapting the geometric displacement of the pump to the quantity required for the consumers.</p> <p>The integrated pressure limitation restricts the maximum pressure to a set value.</p> <p>Coding LSN: Discontinued unit; see Chapter 7.1, "Discontinued controller units"</p>																																				
LSNRT	<p>Load-sensing controller with forced LS relief and integrated pressure limitation.</p> <p>As well as the LSNR controller, the LSNRT contains internal LS signal relief. It is suited to hydraulic systems whose LS relief does not take place in proportional directional spool valves.</p> <p>Internal leakage current ≤ 1.5 lpm</p>																																				
NR	<p>Pressure controller, adjustable directly at the pump.</p> <p>The pressure controller maintains a constant system pressure independently of the required delivery flow. It is suited to constant pressure systems where differing delivery flows are required or for efficient pressure limitation of a hydraulic system.</p> <p>Coding N: Discontinued unit; see Chapter 7.1, "Discontinued controller units"</p>																																				
NXR	<p>Remote-controlled pressure controller. The pressure is set using an externally piped pressure-limiting valve (not included in the scope of delivery).</p>																																				
QNR/...	<p>Flow controller with integrated pressure limitation for setting a constant flow rate independently of the speed. The quantity controller generates a constant differential pressure via an orifice in the P channel. The differential pressure can be adjusted between 20 and 55 bar; the orifice is available in various gradings. This allows flexible adjustment of the volumetric flow.</p> <table border="1"> <thead> <tr> <th>Orifice (mm)</th> <th>Volumetric flow at 20 bar differential pressure (lpm)</th> <th>Orifice (mm)</th> <th>Volumetric flow at 20 bar differential pressure (lpm)</th> </tr> </thead> <tbody> <tr> <td>3</td> <td>approx. 23</td> <td>7</td> <td>approx. 127</td> </tr> <tr> <td>3.5</td> <td>approx. 32</td> <td>7.5</td> <td>approx. 146</td> </tr> <tr> <td>4</td> <td>approx. 42</td> <td>8</td> <td>approx. 166</td> </tr> <tr> <td>4.5</td> <td>approx. 53</td> <td>8.5</td> <td>approx. 188</td> </tr> <tr> <td>5</td> <td>approx. 65</td> <td>9</td> <td>approx. 210</td> </tr> <tr> <td>5.5</td> <td>approx. 65</td> <td>9.5</td> <td>approx. 234</td> </tr> <tr> <td>6</td> <td>approx. 94</td> <td>10</td> <td>approx. 260</td> </tr> <tr> <td>6.5</td> <td>approx. 110</td> <td></td> <td></td> </tr> </tbody> </table>	Orifice (mm)	Volumetric flow at 20 bar differential pressure (lpm)	Orifice (mm)	Volumetric flow at 20 bar differential pressure (lpm)	3	approx. 23	7	approx. 127	3.5	approx. 32	7.5	approx. 146	4	approx. 42	8	approx. 166	4.5	approx. 53	8.5	approx. 188	5	approx. 65	9	approx. 210	5.5	approx. 65	9.5	approx. 234	6	approx. 94	10	approx. 260	6.5	approx. 110		
Orifice (mm)	Volumetric flow at 20 bar differential pressure (lpm)	Orifice (mm)	Volumetric flow at 20 bar differential pressure (lpm)																																		
3	approx. 23	7	approx. 127																																		
3.5	approx. 32	7.5	approx. 146																																		
4	approx. 42	8	approx. 166																																		
4.5	approx. 53	8.5	approx. 188																																		
5	approx. 65	9	approx. 210																																		
5.5	approx. 65	9.5	approx. 234																																		
6	approx. 94	10	approx. 260																																		
6.5	approx. 110																																				

Table 8: Controllers

Coding	Description
PR	<p>Electric proportional pressure controller with increasing characteristic curve. The maximum pressure and minimum pressure can be adjusted mechanically; in between these values, electrical adjustment is possible.</p>
P1R	<p>Electric proportional pressure controller with decreasing characteristic curve. The controller is specifically developed for fan and generator drives. In the event of a power failure, the pump generates the maximum pressure. The maximum pressure and minimum pressure can be mechanically adjusted at the controller.</p>
/V	<p>Size 130: Electric proportional delivery flow controller with increasing characteristic curve. The V controller is an electrically actuated controller that sets an appropriate geometric displacement for the pump in accordance with a current value. Therefore, the pump generates a variable volumetric flow that is dependent on the rotation speed. For use in open centre systems with operating pressures of < 25 bar, an external supply pump or pump pre-load valve must be provided to ensure reliable adjustment. Only in combination with pressure control (codings NR or NXR)</p>
/V1	<p>Size 130: Electric proportional delivery flow controller with decreasing characteristic curve. In comparison with the /V controller, the /V1 controller has a negative characteristic curve, i.e. in the event of power failure, the pump operates at a maximum geometric displacement. For use in open centre systems with operating pressures of < 25 bar, an external supply pump or pump pre-load valve must be provided to ensure reliable adjustment. Only in combination with pressure control (codings NR or NXR)</p>

Table 9 Intermediate plates

Intermediate plate version, only in combination with one of the controllers described above

Coding	Description
/ZL	Size 060, 090, 110 : Intermediate plate with power controller (torque limitation) Product "Pressure x Delivery flow" = constant Adjustment range: 25 ... 100% max. drive torque Coding LLSN, LN: Discontinued units, see Chapter 7.1, "Discontinued controller units"
/ZW	Angled intermediate plate (45°) mandatory for mounting controllers at pumps with housing version -2, -3
/L	Adjustment range: 200 - 700 Nm Size 130 : Power controller (standard)
/PR	Electric proportional pressure controller with increasing characteristic curve. The maximum pressure and minimum pressure can be adjusted mechanically; in between these values, electrical adjustment is possible.
/ZV	Size 060, 090, 110 : Electric proportional delivery flow controller with increasing characteristic curve. For use in open centre systems with operating pressures of < 25 bar, an external supply pump or pump pre-load valve must be provided to ensure reliable adjustment. The ZV controller is designed as an intermediate plate. (It acts on the set piston from above and electrically adjusts the pivoting angle of the pump.)
/ZV1	Size 060, 090, 110 : Electric proportional delivery flow controller with decreasing characteristic curve. For use in open centre systems with operating pressures of < 25 bar, an external supply pump or pump pre-load valve must be provided to ensure reliable adjustment. The ZV1 controller is designed as an intermediate plate. (It acts on the set piston from above and electrically adjusts the pivoting angle of the pump.)

Table 10 Solenoid voltage and version

Coding	Nominal voltage	Description
G 12 G 24	12 V DC 24 V DC	Version with connection DIN EN 301-803 With male connector
S 12 S 24	12 V DC 24 V DC	Version with bayonet connection (bayonet PA 6, SCHLEMMER, suitable for cone with bayonet 10 SL). The delivery does not include a male connector.

Table 11 Stroke limitation

Coding	Description
No designation	No stroke limitation
2	With adjustable stroke limitation (for housing version 1 and 4: all sizes, for housing version 2 and 3: only V60N-090, V60N-130)
2/...	Stroke limitation fixed with specification of the set geometric displacement V_g (cm ³ /rev.)

Table 12 Ports

Coding	Ports
No designation	ISO 228/1
UNF	SAE J 514

Order coding example:

V60N-110 RDYN-2-0-01/LSNR-350-A00/76- C 022

Table 13 Flange versions (output side)

Coding V60N			Flange	Shaft
060	090/110	130		
C 010	--	C 030	ISO 7653-1985	DIN ISO 14
C 011	C 021	C 031	SAE-A 2-hole J 744 82-2 ISO 3019-1	SAE-A J 744 (16-4 ISO 3019-1) 9T 16/32 DP
C 012	C 022	C 032	SAE-A 2-hole J 744 82-2 ISO 3019-1	SAE-A J 744 (16-4 ISO 3019-1) ¹⁾ 9T 16/32 DP ¹⁾
C 013	--	--	SAE-A 2-hole J 744 82-2 ISO 3019-1	19-4 ISO 3019-1 11T 16/32 DP
C 014	C 024	C 034	SAE-B 2-hole J 744 101-2 ISO 3019-1	SAE-B J 744 (22-4 ISO 3019-1) 13T 16/32 DP
--	--	--	SAE-B 2-hole J 744 101-2 ISO 3019-1	SAE-BB J 744 (25-4 ISO 3019-1) 15T 12/24 DP
C 015	C 025	C 035	SAE-B 4-hole J 744 101-4 ISO 3019-1	SAE-B J 744 (22-4 ISO 3019-1) 13T 16/32 DP
--	C 027	C 037	SAE-C 2-hole J 744 127-2 ISO 3019-1	SAE-C J 744 (32-4 ISO 3019-1) 14T 12/24 DP
--	C 028	C 038	SAE-C 4-hole J 744 127-4 ISO 3019-1	SAE-C J 744 (32-4 ISO 3019-1) 14T 12/24 DP

Note

Pay attention to the maximum permissible drive torque, as the flange or shaft may be damaged otherwise.



Note

An additional support is to be provided for pump combinations.
Other versions on request.

¹⁾ ANSI B 92.1, FLAT ROOT SIDE FIT, spline width deviating from the standard, s = 2.357-0.03

2.2 Controller switching symbols

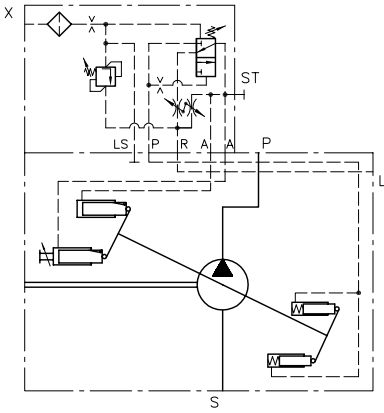
Coding LSNR



Coding LSNRT

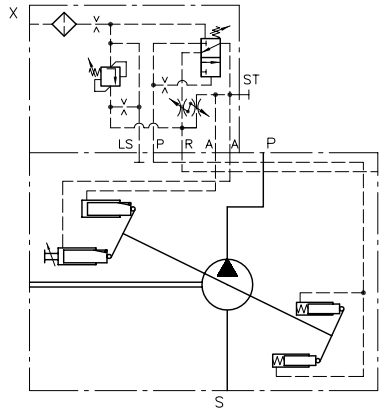

Coding QNR

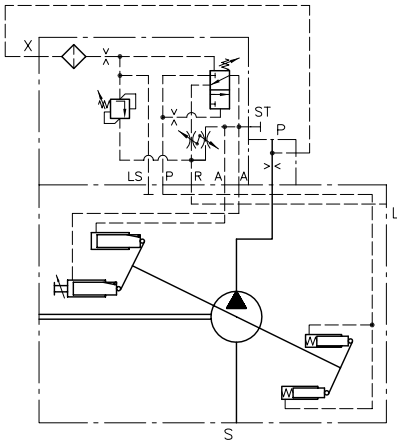

Coding NR

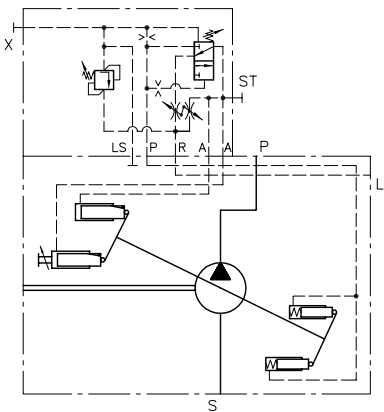

Coding NXR

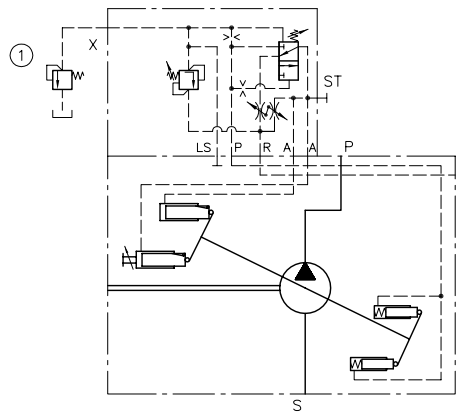

- 1 External pressure-limiting valve
(not included in scope of delivery)

Coding PR

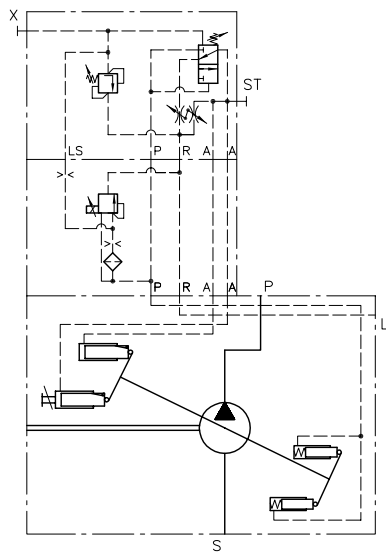

Coding P1R

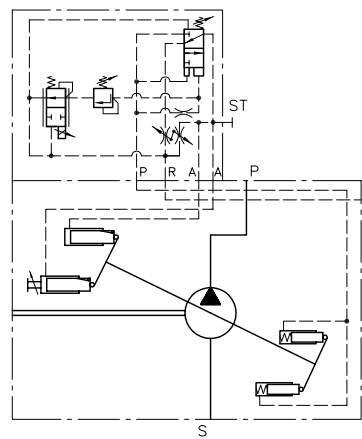

Types V60N-060, V60N-090, V60N-110

Coding .../ZL

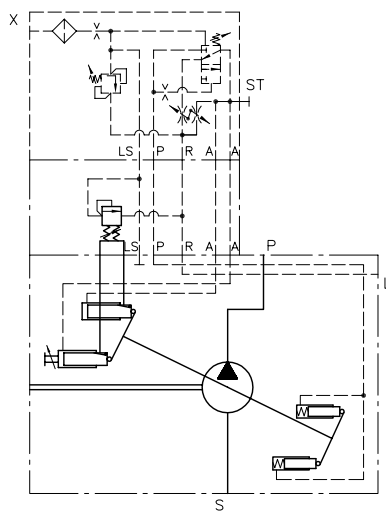

Coding .../ZV

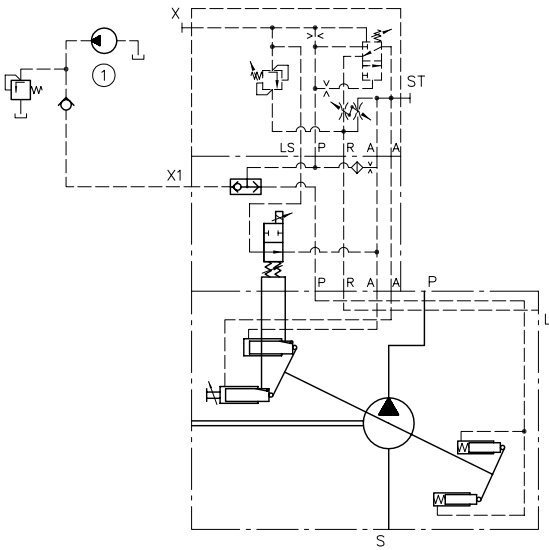

- 1 External supply pump with pressure-limiting valve and check valve (not included in scope of delivery)

Coding .../ZV1

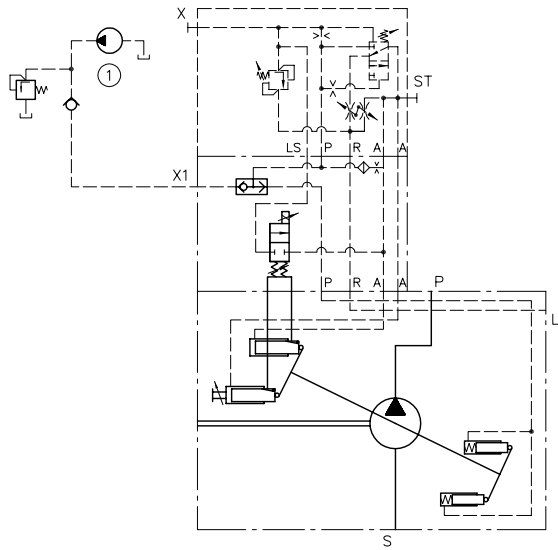

- 1 External supply pump with pressure-limiting valve and check valve (not included in scope of delivery)

Type V60N-130

Coding .../L

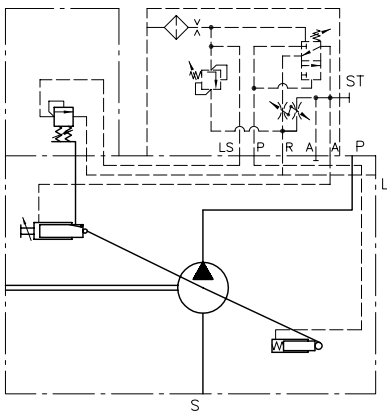

Coding .../V

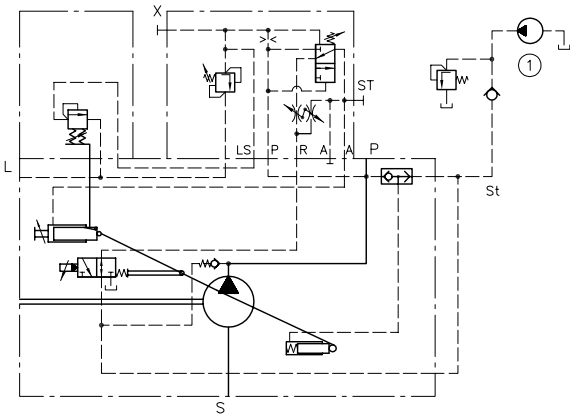

- 1 External supply pump with pressure-limiting valve and check valve (not included in scope of delivery)

Coding .../V1

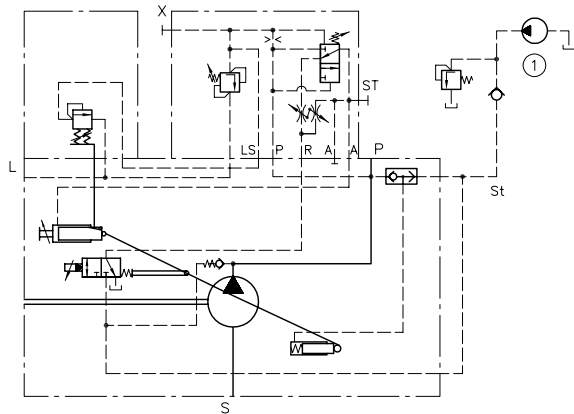

- 1 External supply pump with pressure-limiting valve and check valve (not included in scope of delivery)

3 Parameters

3.1 General

Description	Variable displacement axial piston pump
Design	Axial piston pump according to the swash plate principle
Mounting	Power take-off on commercial vehicle gearboxes (flange ISO 7653-1985 for trucks) or flange mounting
Surface	Primed
Drive/output torque	See Chapter 3, "Parameters" , under "Additional parameters"
Installation position	Any (for installation information see Chapter 5, "Installation information")
Rotating direction	Clockwise or anti-clockwise
Change of rotating direction	V60N-060...-110: Turn the end plate of the pump (see dimension diagram) and replace the port plate; see also Assembly instructions for variable displacement axial piston pump type V60N: B 7960 N
Ports	<ul style="list-style-type: none"> ▪ Suction port ▪ Pressure port ▪ Drain port ▪ Pressure gauge connection
Hydraulic fluid	Hydraulic oil: according to DIN 51 524 Part 1 to 3; ISO VG 10 to 68 according to DIN 51 519 Viscosity range: min. approx. 10; max. approx. 1000 mm ² /s Optimal operating range: 16 to 35 mm ² /s Also suitable for biologically degradable pressure fluids type HEPG (polyalkalene glycol) and HEES (synthetic ester) at operating temperatures up to approx. +70°C.
Purity class	ISO 4406 <hr/> 19/17/14
Temperatures	Ambient: approx. -40 to +60°C, oil: -25 to +80°C, pay attention to the viscosity range! Start temperature: down to -40°C is permissible (observe start-viscosity!), as long as the steady-state temperature is at least 20K higher for subsequent operation. Biologically degradable pressure fluids: note manufacturer specifications. With consideration for the seal compatibility, not above +70°C.

Pressure and delivery flow

Operating pressure	See Chapter 2, "Available versions, main data"
Geometric displacement	See Chapter 2, "Available versions, main data"

Dimensions

Type V60N	With controller (kg)
060	24
090	27
110	30
130	30.8

Additional parameters

Description	Nominal size			
	060	090	110	130
Max. swash plate angle	20.5°	21.5°	21.5°	21.5°
Absolute inlet pressure required in open circuit	0.85 bar	0.85 bar	0.85 bar	0.85 bar
Max. permissible housing pressure (static/dynamic)	2 bar/3 bar	2 bar/3 bar	2 bar/3 bar	2 bar/3 bar
Max. permissible inlet pressure (static/dynamic)	20 bar/30 bar	20 bar/30 bar	20 bar/30 bar	20 bar/30 bar
Max. rotation speed during suction operation and max. swash plate angle at 1 bar abs. Inlet pressure	2500 rpm	2300 rpm	2200 rpm	2100 rpm
Max. rotation speed with zero stroke and 1 bar abs. Inlet pressure	3000 rpm	3000 rpm	3000 rpm	3000 rpm
Min. rotation speed in continuous operation	500 rpm	500 rpm	500 rpm	500 rpm
Required drive torque at 100 bar	100 Nm	151 Nm	184 Nm	230 Nm
Drive power at 250 bar and 2000 rpm	53 kW	79.5 kW	97.2 kW	120 kW
Weight torque	30 Nm	35.5 Nm	40 Nm	40 Nm
Inertia torque	0.005 kg m ²	0.008 kg m ²	0.01 kg m ²	0.011 kg m ²
Noise level at 250 bar, 1500 rpm and max. swash plate angle (measured in acoustic measurement chamber according to DIN ISO 4412, measurement distance 1 m)	75 dB(A)	75 dB(A)	75 dB(A)	75 dB(A)

Max. permissible drive/output torque

Description		Nominal size			
		060	090	110	130
Parallel key splined shaft D	Drive/output	530 Nm/100 Nm	800 Nm/600 Nm	800 Nm/600 Nm	800 Nm/700 Nm
Spline shaft M	Drive/output	--	530 Nm/530 Nm	530 Nm/530 Nm	--
Spline shaft H	Drive/output	210 Nm/100 Nm	--	--	--
Spline shaft U	Drive/output	210 Nm/100 Nm	--	--	--
Spline shaft T	Drive/output	340 Nm/100 Nm	--	--	--
Spline shaft S	Drive/output	530 Nm/100 Nm	640 Nm/600 Nm	640 Nm/600 Nm	640 Nm/640 Nm
Spline shaft Q	Drive/output	--	900 Nm/600 Nm	900 Nm/600 Nm	900 Nm/700 Nm

3.2 Planning information for parameters

Determination of nominal sizes

Delivery flow	$Q = \frac{V_g \cdot n \cdot \eta_v}{1000} (l/min)$	V_g	= Geom. output volume (cm ³ /rev.)
Drive torque	$M = \frac{V_g \cdot \Delta p}{20 \cdot \pi \cdot \eta_{mh}} (Nm)$	Δp	= Differential pressure
Drive power	$P = \frac{2\pi \cdot M \cdot n}{60000} = \frac{Q \cdot \Delta p}{600 \cdot \eta_t} (kW)$	n	= Rotation speed (rpm)
		η_v	= Volumetric efficiency
		η_{mh}	= Mechanical-hydraulic efficiency
		η_t	= Overall efficiency ($\eta_t = \eta_v \cdot \eta_{mh}$)

3.3 Characteristic curves

Delivery flow and power (basic pump)

The diagrams illustrate the delivery flow/pressure (without controller). Drive power at max. swash plate angle and drive power at zero stroke and 1500 rpm.

Drive power/pressure at zero stroke and 1500 rpm

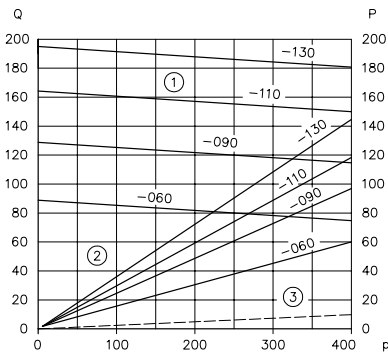

Figure 3: p pressure (bar); Q delivery flow (lpm); P power (kW)

- 1 Delivery flow/pressure
- 2 Drive power/pressure
- 3 Drive power/pressure (zero stroke)

Inlet pressure and self-suction speed

The diagrams show the inlet pressure/rotation speed at the max. swash plate angle and an oil viscosity of 75 mm²/s.

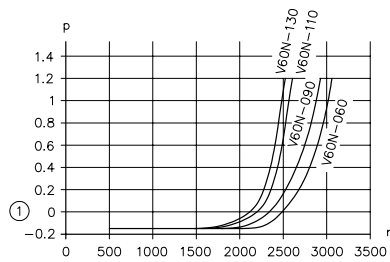

Figure 4: n rotation speed (rpm); p inlet pressure (bar)

- 1 0 bar relative = 1 bar absolute

3.4 Controller characteristic curves

Codings /ZL, /L

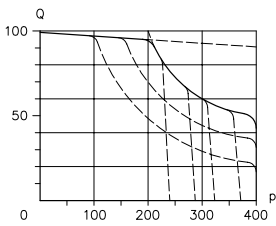

Figure 5: p pressure (bar); Q delivery flow (%)

Codings LSNR, PR, P1R

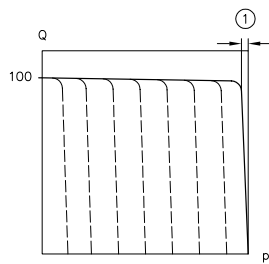

Figure 6: p_B operating pressure (bar); Q delivery flow (%)

1 Approx. 4 bar

Codings V, V1, ZV, ZV1

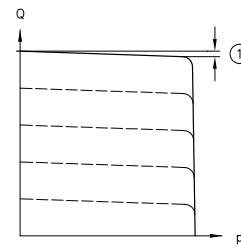

Figure 7: p_B operating pressure (bar); Q delivery flow (%)

1 Approx. 5%

Coding QNR

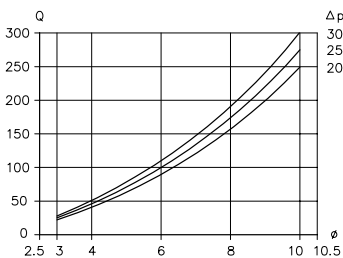

Figure 8: Ø orifice diameter (mm); Q delivery flow (%)

Determination of the delivery flow Q (lpm)

Q	= $0,55 \cdot d^2 \sqrt{\Delta p}$
d	= orifice diameter (mm)
Δp	= pressure differential

Coding PR

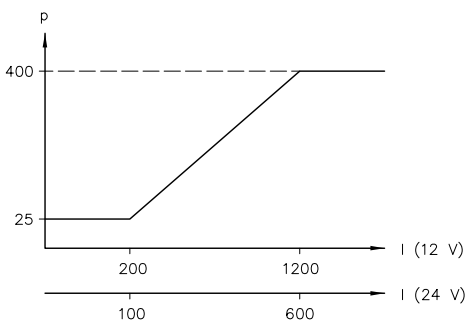

Figure 9: I current (mA); p pressure (bar)

Coding V

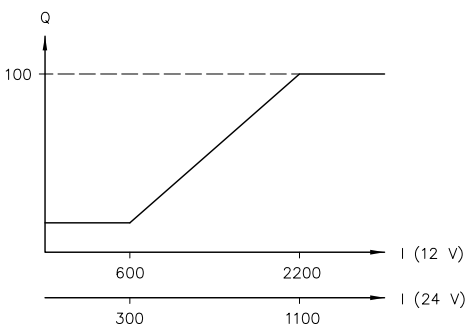

Figure 11: I current (mA); Q delivery flow (%)

Coding P1R

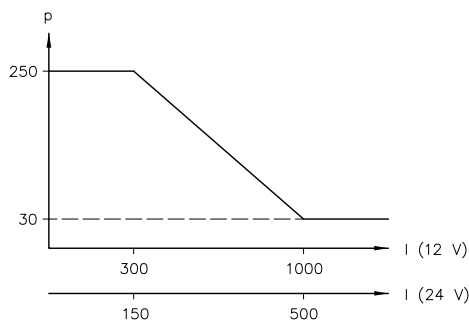

Figure 10: I current (mA); p pressure (bar)

Coding V1

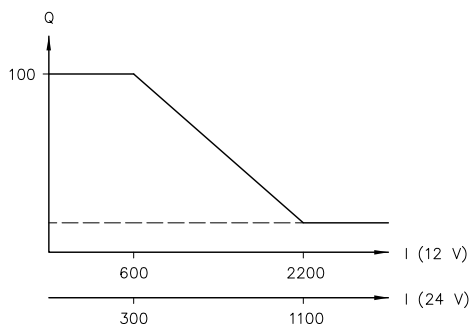

Figure 12: I current (mA); Q delivery flow (%)

Coding ZV

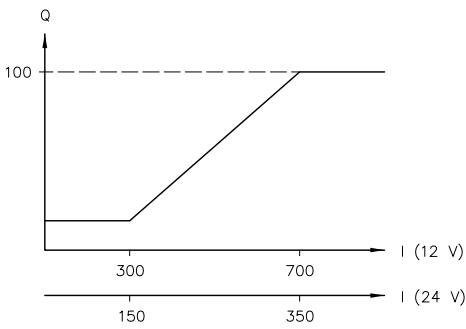

Figure 13: I current (mA); Q delivery flow (%)

Coding ZV1

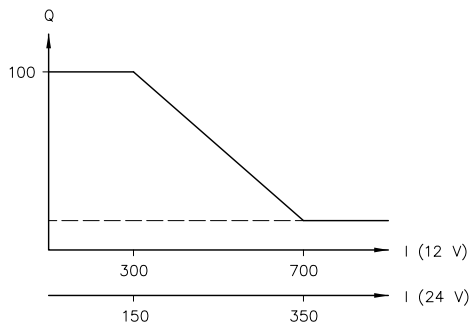

Figure 14: I current (mA); Q delivery flow (%)

Acting times T1 (LSNR controller)

The diagram shows the on-stroke time/pressure for the LSNR controller; i.e. the time that is required to swivel out the pump and adjust from the minimum to the maximum geometric displacement.

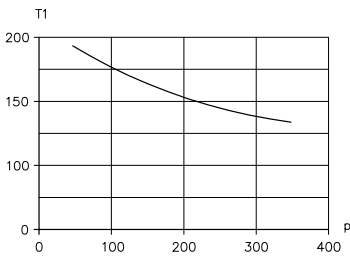

Figure 15: p pressure (bar); acting time T1 (ms)

Acting times T2 (LSNR controller)

The diagram shows the destroke time/pressure for the LSNR controller, i.e. the time required to swing in the pump and to adjust the geometric displacement from the maximum to the minimum.

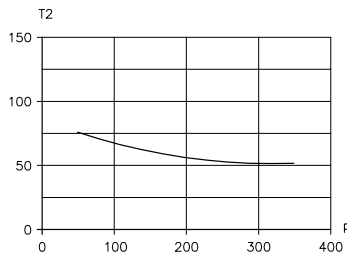

Figure 16: p pressure (bar); acting time T2 (ms)

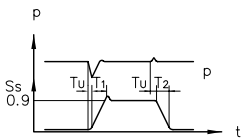

Figure 17: t in ms; p pressure (bar)

S_s	= positioning travel of actuator
T_u	= delay < 3 ms
T_1	= on-stroke time
T_2	= destroke time
p	= pressure

LS line approx. 10% of the volume of the P line

4 Dimensions

All dimensions in mm, subject to change!

4.1 Basic pump

4.1.1 Type V60N-060

Rotating direction **clockwise** (viewed from shaft journal)

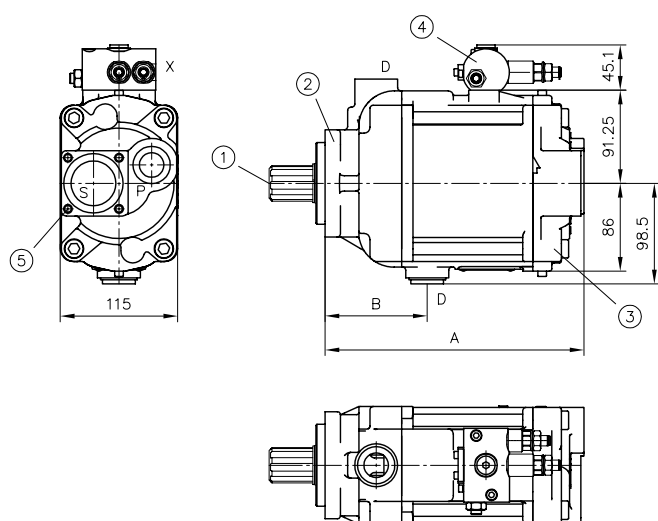

Rotating direction **anti-clockwise** (viewed from shaft journal)

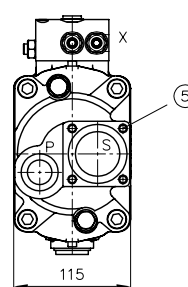

- 1 Shaft version
- 2 Flange version
- 3 Housing version
- 4 Controller and intermediate plates according to Section 4.2
- 5 Delivery includes attachment kit for suction intakes according to Section 7.2

Flange version	Housing version	A	B
Y	-1	253.5	100.0
F, Z, X	-1	249.8	96.3
Y	-2, -3	292.0	100.0
F, Z, X	-2, -3	288.3	96.3

Ports P, S and D (ISO 228/1 (BSPP))

P	Pressure port G 3/4
S	Flange suction port
D	Drain port G 3/4
X	G 1/4

For coding UNF, ports SAE J 514

P	Pressure port 1/16-12 UN-2B
S	Flange suction port
D	Drain port 1 1/16-12 UN-2B
X	G 1/4 (ISO 228/1 (BSPP)) with adapter for 7/16-20 (SAE-4)

Stroke limitation

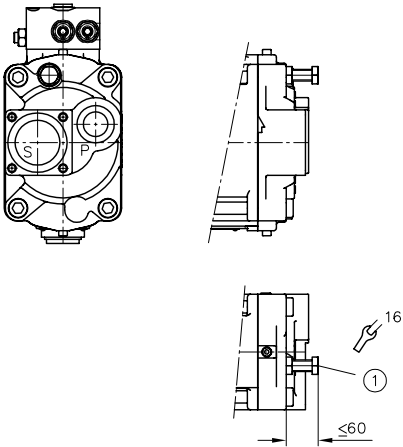

1 Stroke limitation (V_g approx. 4 cm³/rev.)

Shaft versions

Parallel key splined shaft
Coding **D**
(similar to DIN ISO 14)

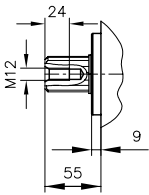

Spline shaft
Coding **S**
(SAE-C 14T 12/24DP)

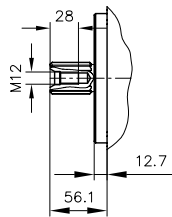

Spline shaft
Coding **T**
(SAE-B-B 15T 16/32DP)

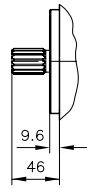

Spline shaft
Coding **H**
(SAE-B 13T 16/32DP)

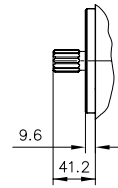

Spline shaft
Coding **U**
(SAE-B 13T 16/32DP short)

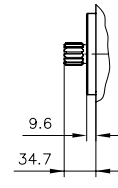

Flange versions

Coding Y
(ISO 7653-1985)

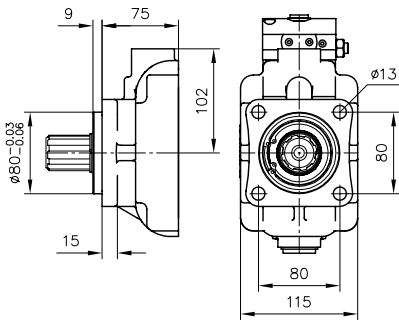

Coding F
(SAE-C 4-hole)
(127-4 ISO 3019-1)

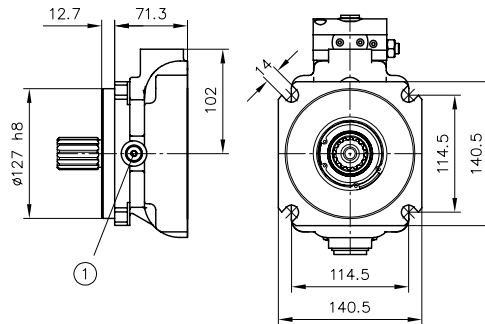

1 Bleeding G 1/8

Coding Z
(SAE-B 4-hole)
(101-4 ISO 3019-1)

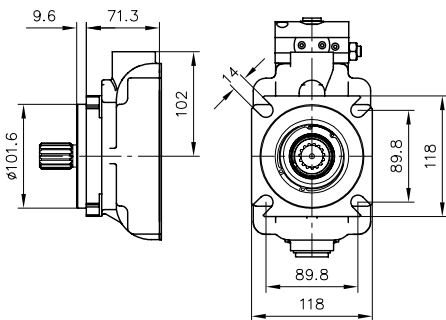

Coding X
(SAE-B 2-hole)
(101-2 ISO 3019-1)

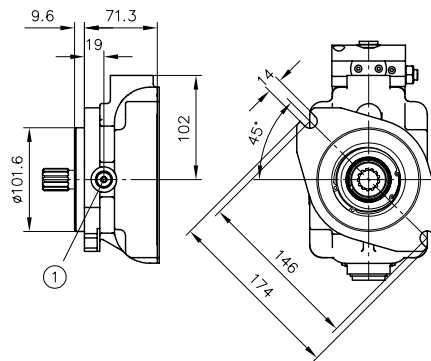

1 Bleeding G 1/8

Housing version -1 (axial ports)

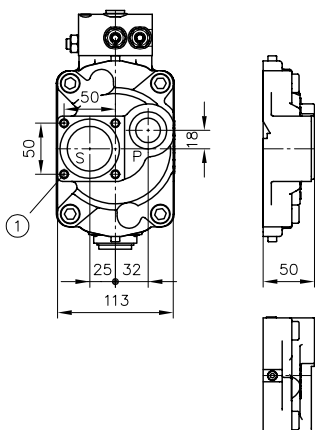

1 Delivery includes attachment kit for suction intakes according to Section 7.2

Housing version -2 (radial ports, with thru-shaft)

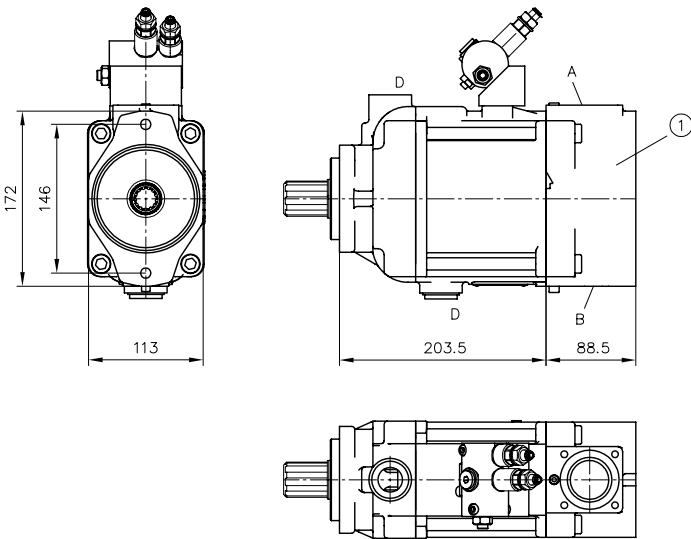

1 Flange version (output side)

Rotating direction clockwise

A = suction port

B = pressure port

Rotating direction anti-clockwise

A = pressure port

B = suction port

Flange version (output side)

Coding **C 010**
(ISO 7653-1985)

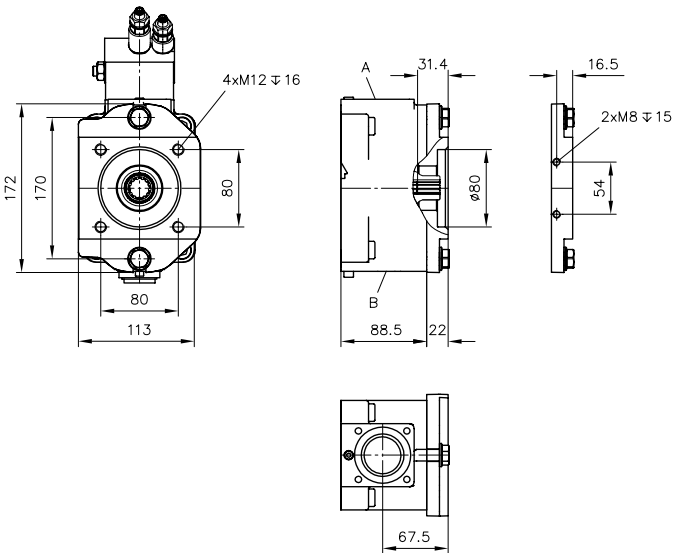

Coding **C 011, C 012**
(SAE-A 2-Hole)

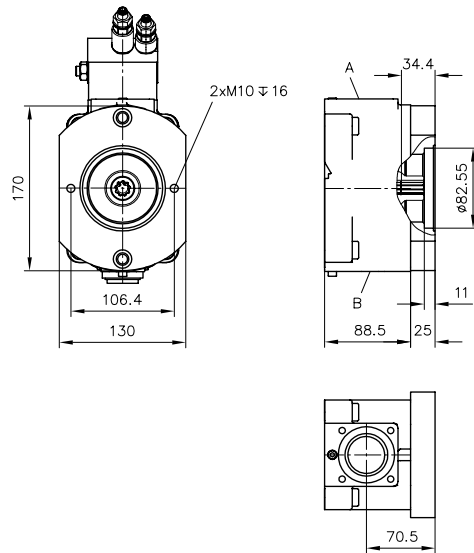

Coding **C 014**
(SAE-B 2-hole)

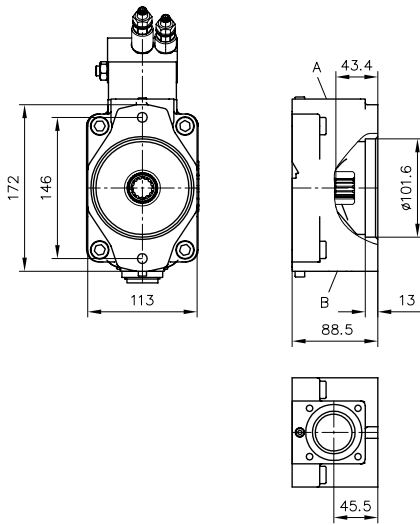

Coding **C 015**
(SAE-B 4-hole)

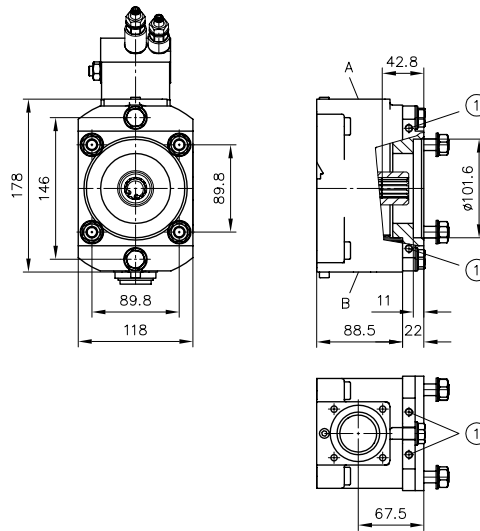

1 Support 8xM8

Housing version -3 (radial ports)

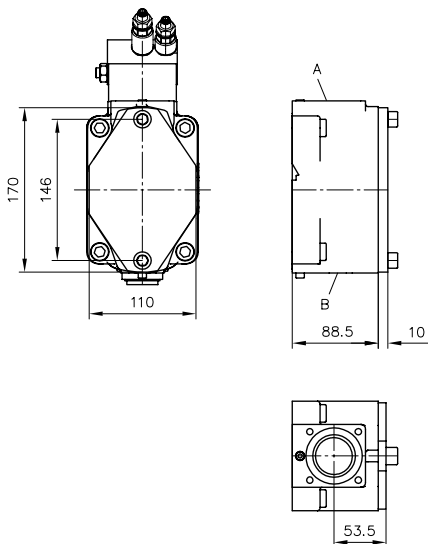

Rotating direction clockwise

A = suction port
B = pressure port

Rotating direction anti-clockwise

A = pressure port
B = suction port

4.1.2 Type V60N-090

Rotating direction **clockwise** (viewed from shaft journal)

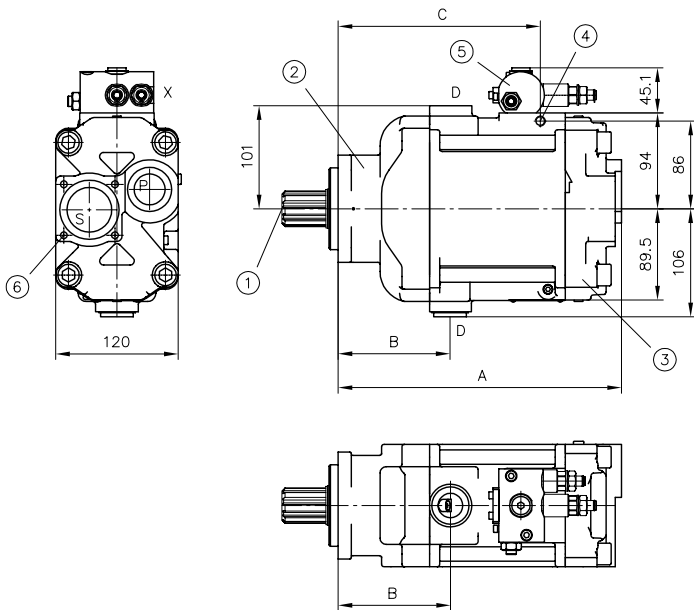

Rotating direction **anti-clockwise** (viewed from shaft journal)

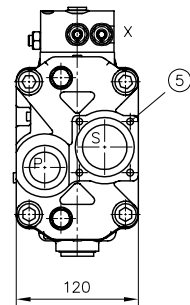

- 1 Shaft version
- 2 Flange version
- 3 Housing version
- 4 Thread M10 for attaching a bracket
- 5 Controller and intermediate plates according to Section 4.2
- 6 Delivery includes attachment kit for suction intakes according to Section 7.2

Flange version	Housing version	A	B	C
Y	-1	277.5	110.0	198.0
F, G	-1	273.8	106.3	194.3
Y	-2, -3	310.5	110.0	198.0
F, G	-2, -3	306.8	106.3	194.3

Ports P, S and D (ISO 228/1 (BSPP))

P	Pressure port G 1
S	Flange suction port
D	Drain port G 3/4
X	G 1/4

For coding UNF, ports SAE J 514

P	Pressure port 1 5/16-12 UN-2B
S	Flange suction port
D	Drain port 1 1/16-12 UN-2B
X	G 1/4 (ISO 228/1 (BSPP)) with adapter for 7/16-20 (SAE-4)

Stroke limitation

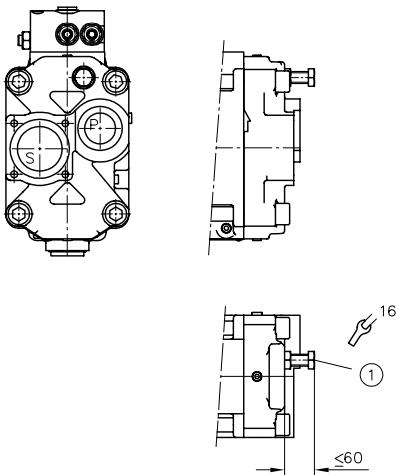

1 Stroke limitation (V_g approx. 5 cm³/rev.)

Shaft versions

Parallel key splined shaft
Coding **D**
(similar to DIN ISO 14)

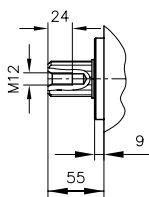

Spline shaft
Coding **S**
(SAE-C 14T 12/24DP)

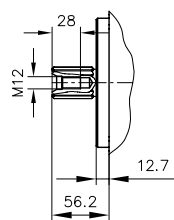

Spline shaft
Coding **M**
(DIN 5480 W30x2x14x9g)

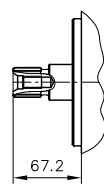

Spline shaft
Coding **Q**
(SAE-CS)

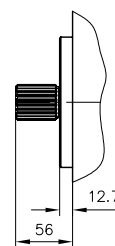

Flange versions

Coding **Y**
(ISO 7653-1985)

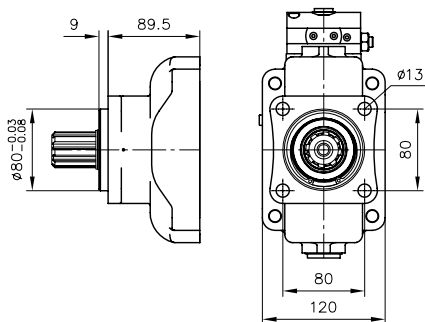

Coding **F**
(SAE-C 4-hole)
(127-4 ISO 3019-1)

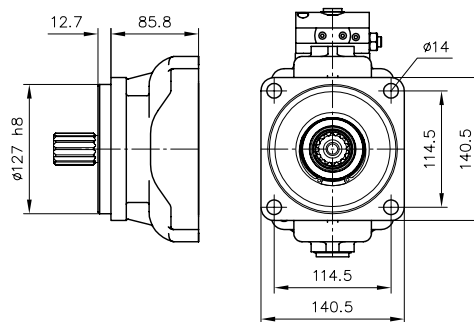

Coding **G**
(125 B4 HW ISO 3019-2)

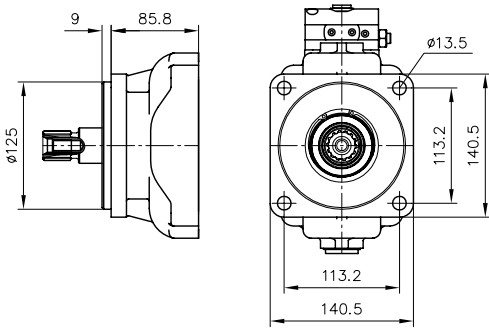

Housing version -1 (axial ports)

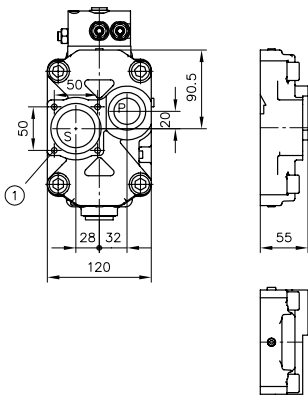

1 Delivery includes attachment kit for suction intakes according to Section 7.2

Housing version -2 (radial ports, with thru-shaft)

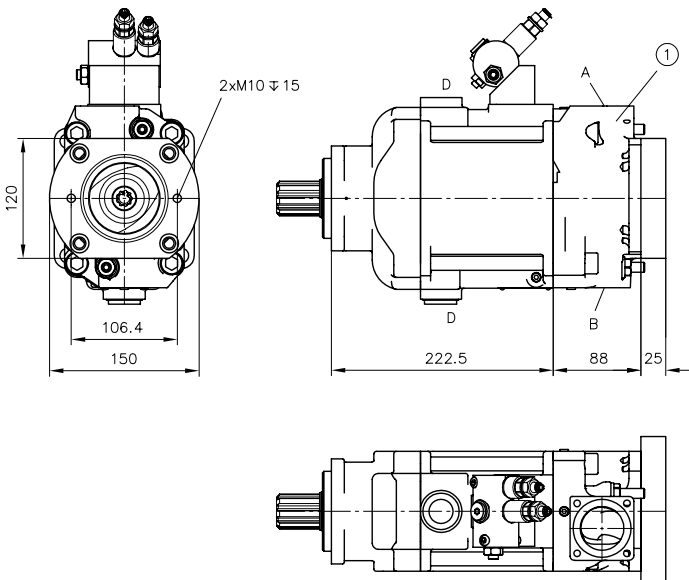

1 Flange version (output side)

Rotating direction clockwise	Rotating direction anti-clockwise
A = suction port	A = pressure port
B = pressure port	B = suction port

Flange version (output side)

Coding **C 021, C 022**
(SAE-A 2-hole)

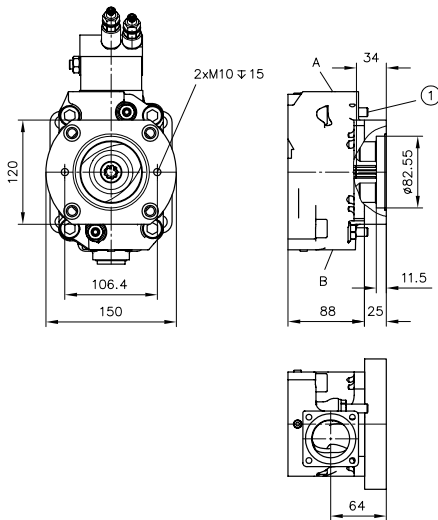

1 Stroke limitation

Coding **C 024**
(SAE-B 2-hole)

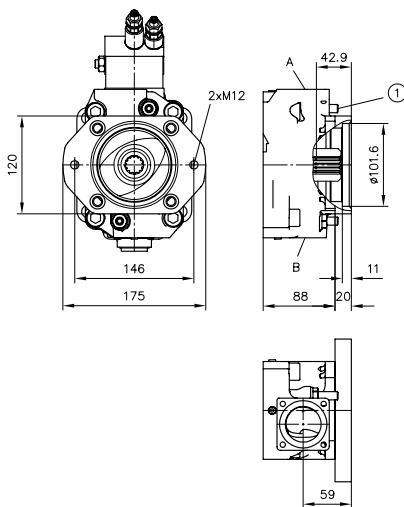

1 Stroke limitation

Coding **C 025**
(SAE-B 4-hole)

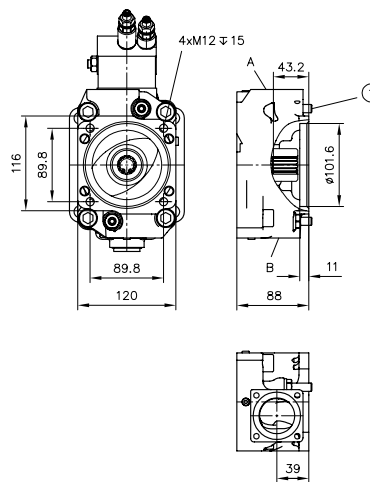

1 Stroke limitation

Coding **C 027**
(SAE-C 2-hole)

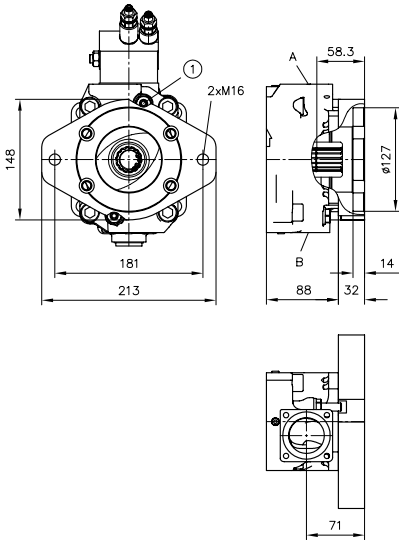

1 Stroke limitation

Coding **C 028**
(SAE-C 4-hole)

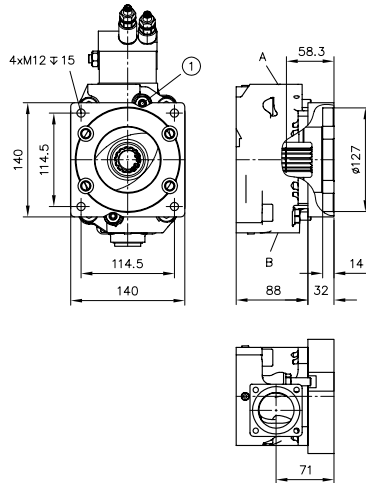

1 Stroke limitation

Housing version -3 (radial ports)

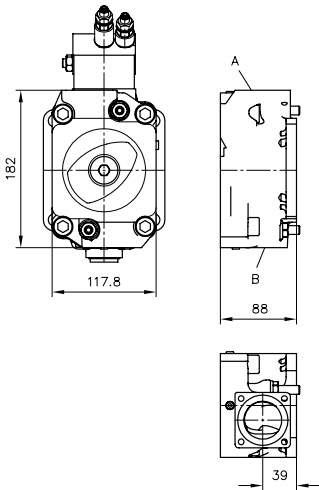

Rotating direction clockwise

A = suction port

B = pressure port

Rotating direction anti-clockwise

A = pressure port

B = suction port

Housing version -4 (axial ports)

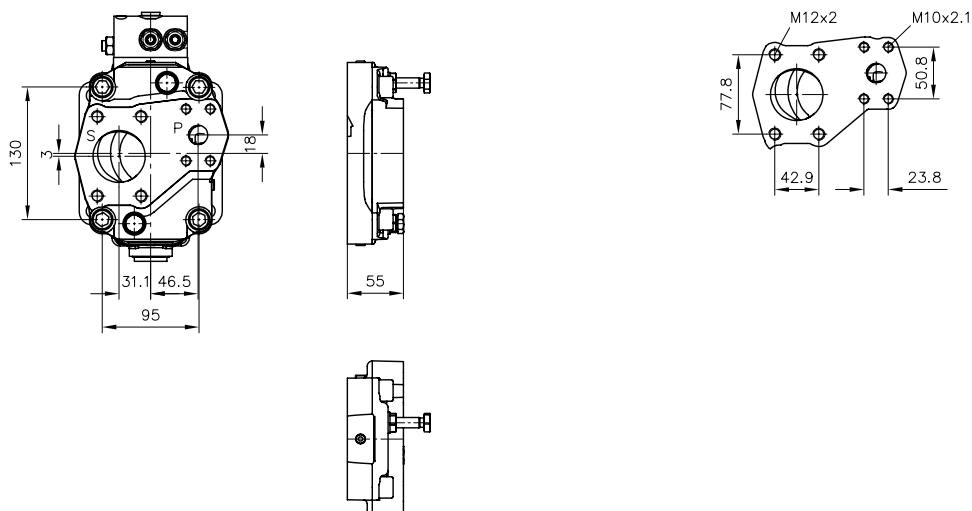

Ports P, S (SAE J 518)

P	Pressure port SAE 3/4"	(6000 psi)
S	Suction port SAE 2"	(3000 psi)

4.1.3 Type V60N-110

Rotating direction **clockwise** (viewed from shaft journal)

Rotating direction **anti-clockwise** (viewed from shaft journal)

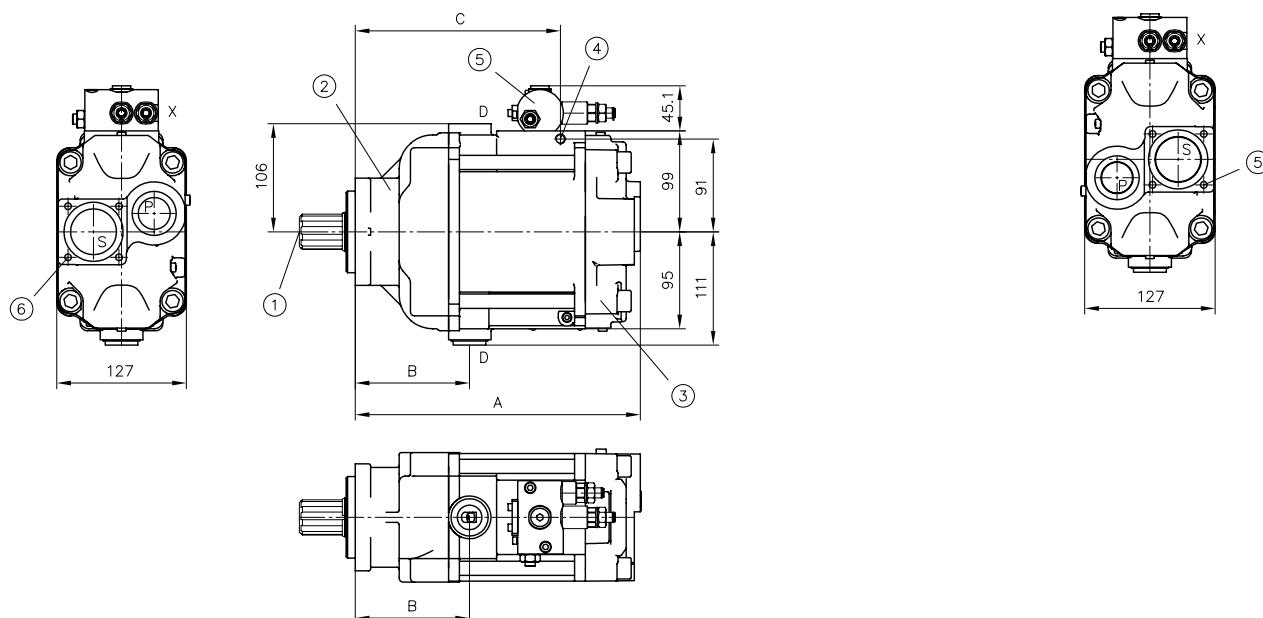

- 1 Shaft version
- 2 Flange version
- 3 Housing version
- 4 Thread M10 for attaching a bracket
- 5 Controller and intermediate plates according to Section 4.2
- 6 Delivery includes attachment kit for suction intakes according to Section 7.2

Flange version	Housing version	A	B	C
Y	-1	279.5	112.0	201.0
F	-1	275.7	108.7	197.7
P	-1	278.5	111.0	200.0
Y	-2, -3	313.5	112.0	201.0
F	-2, -3	309.7	108.2	197.7
P	-2, -3	312.5	111.0	200.0

Ports P, S and D (ISO 228/1 (BSPP))

P	Pressure port G 1
S	Flange suction port
D	Drain port G 3/4
X	G 1/4

For coding UNF, ports SAE J 514

P	Pressure port 1 5/16-12 UN-2B
S	Flange suction port
D	Drain port 1 1/16-12 UN-2B
X	G 1/4 (ISO 228/1 (BSPP)) with adapter for 7/16-20 (SAE-4)

Stroke limitation

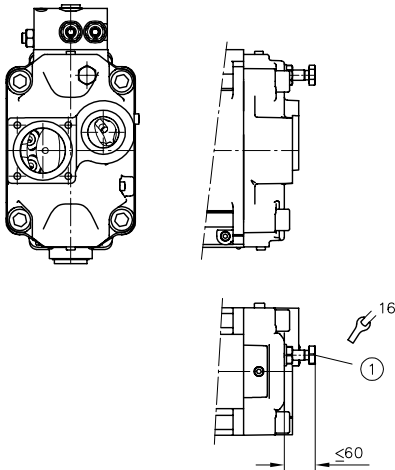

1 Stroke limitation (V_g approx. 6 cm³/rev.)

Shaft versions

Parallel key splined shaft

Coding **D**
(similar to DIN ISO 14)

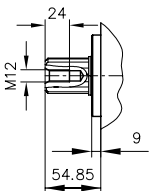

Spline shaft

Coding **S**
(SAE-C 14T 12/24DP)

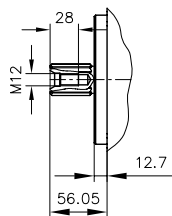

Spline shaft

Coding **M**
(DIN 5480 W30x2x14x9g)

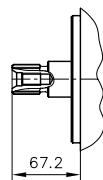

Spline shaft

Coding **Q**
(SAE-CS)

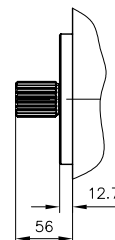

Flange versions

Coding **Y**
(ISO 7653-1985)

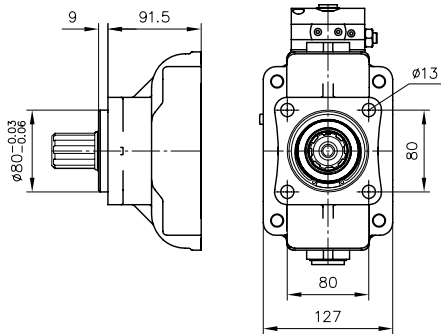

Coding **F**
(SAE-C 4-hole)
(127-4 ISO 3019-1)

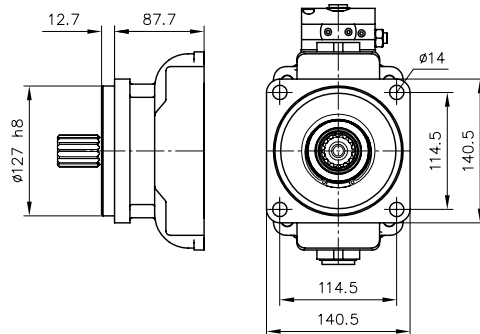

Coding **P**
(ISO 7653-1985)

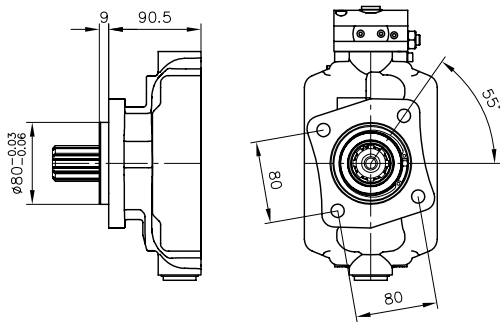

Housing version -1 (axial ports)

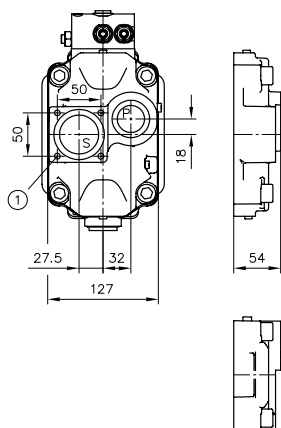

1 Delivery includes attachment kit for suction intakes according to Section 7.2

Housing version -2 (radial ports with thru-shaft)

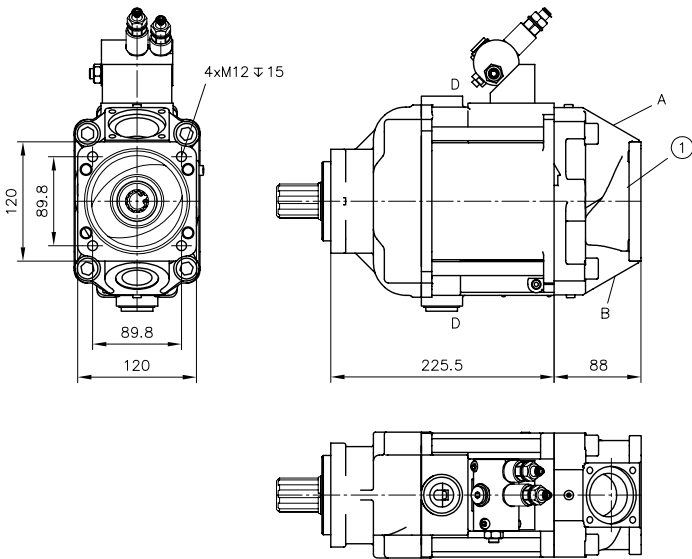

1 Flange version (output side)

Rotating direction clockwise

A = suction port

B = pressure port

Rotating direction anti-clockwise

A = pressure port

B = suction port

Flange version (output side)

Coding **C 021, C 022**
(SAE-A 2-hole)

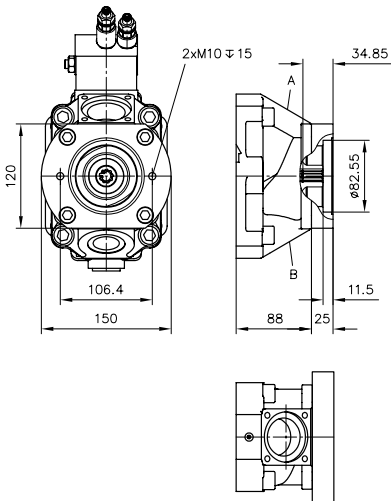

Coding **C 024**
(SAE-B 2-hole)

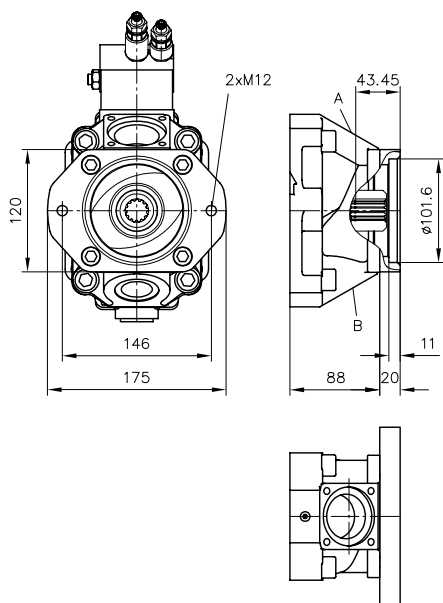

Coding **C 025**
(SAE-B 4-hole)

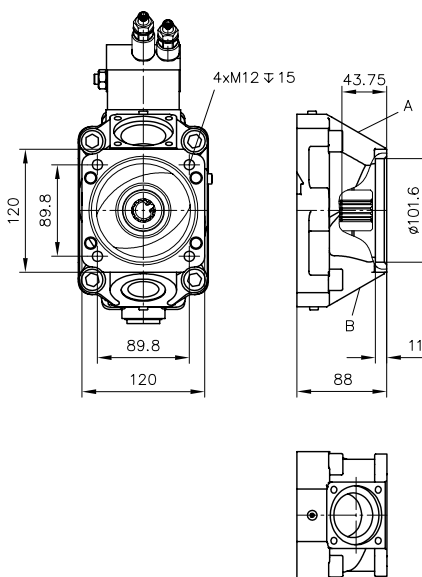

Coding **C 027**
(SAE-C 2-hole)

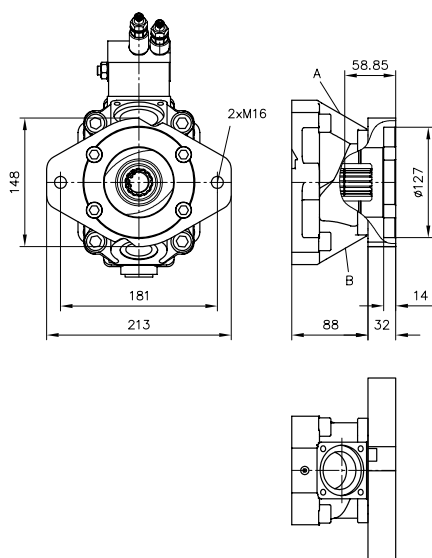

Coding **C 028**
(SAE-C 4-hole)

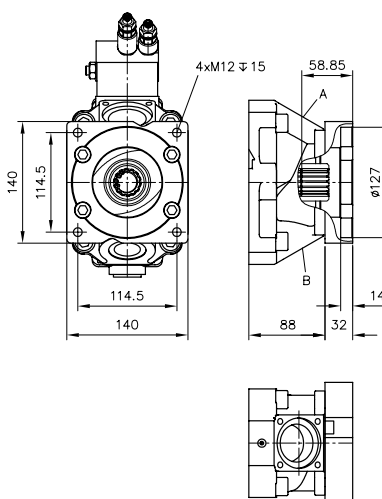

Housing version -3 (radial ports)

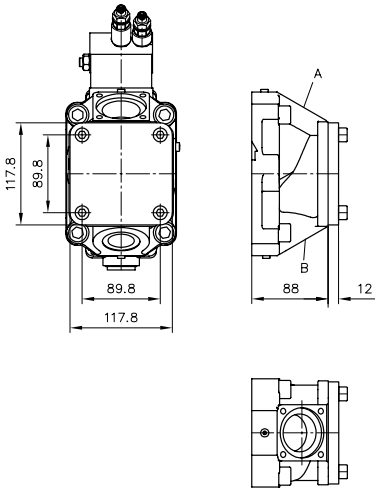

Rotating direction clockwise

A = suction port

B = pressure port

Rotating direction anti-clockwise

A = pressure port

B = suction port

4.1.4 Type V60N-130

Rotating direction **clockwise** (viewed from shaft journal)

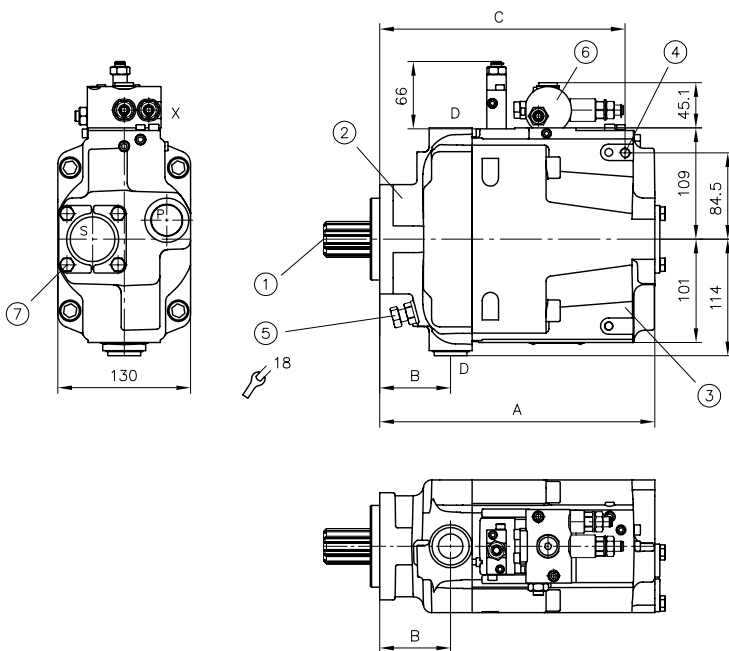

Rotating direction **anti-clockwise** (viewed from shaft journal)

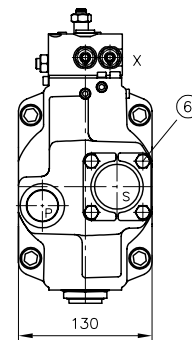

- 1 Shaft version
- 2 Flange version
- 3 Housing version
- 4 Thread M10 for attaching a bracket
- 5 Stroke limitation (13 cm³/rev.)
- 6 Controller and intermediate plates according to Section 4.2
- 7 Delivery includes attachment kit for suction intakes according to Section 7.2

Flange version	Housing version	A	B	C
Y, P	-1	269.5	69.5	240.5
F	-1	266.8	66.8	237.8
Y, P	-2	323.5	69.5	240.5
F	-2	320.8	66.8	237.8

Ports P, S and D (ISO 228/1 (BSPP))

P	Pressure port G 1
S	Flange suction port
D	Drain port G 3/4
X	G 1/4

For coding UNF, ports SAE J 514

P	Pressure port 1 5/16-12 UN-2B
S	Flange suction port
D	Drain port 1 1/16-12 UN-2B
X	G 1/4 (ISO 228/1 (BSPP)) with adapter for 7/16-20 (SAE-4)

Shaft versions

Spline shaft

Coding **D**
(similar to DIN ISO 14)

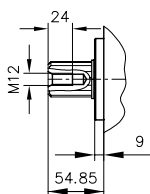

Spline shaft

Coding **S**
(SAE-C 14T 12/24DP)

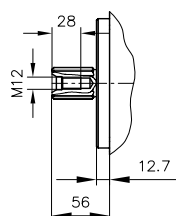

Spline shaft

Coding **Q**
(SAE-CS)

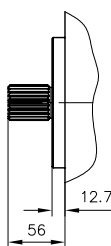

Flange versions

Coding Y

(ISO 7653-1985)

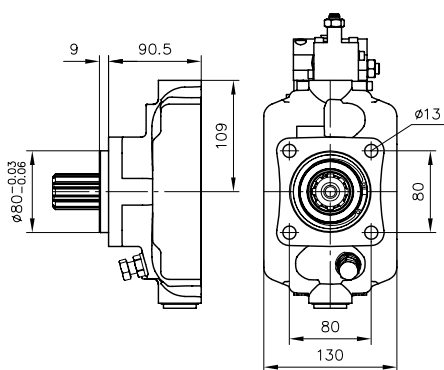

Coding F

(SAE-C 4-hole)
(127-4 ISO 3019-1)

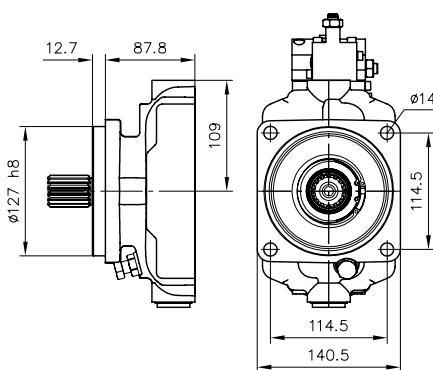

Coding P
(ISO 7653-1985)

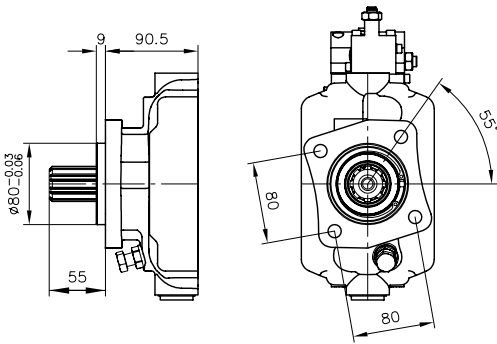

Housing version -1 (axial ports)

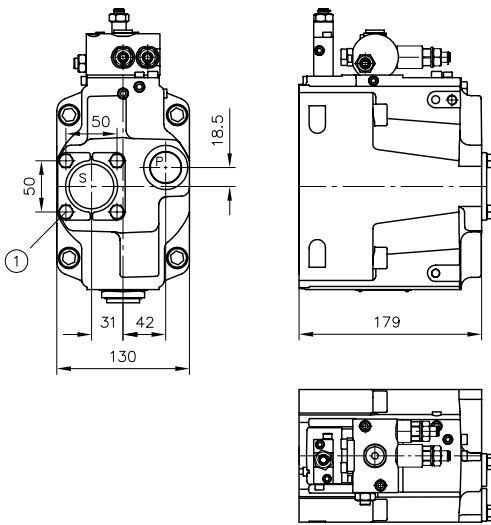

1 Delivery includes attachment kit for suction intakes according to Section 7.2

Housing version -2 (radial ports, with thru-shaft)

Rotating direction **clockwise**

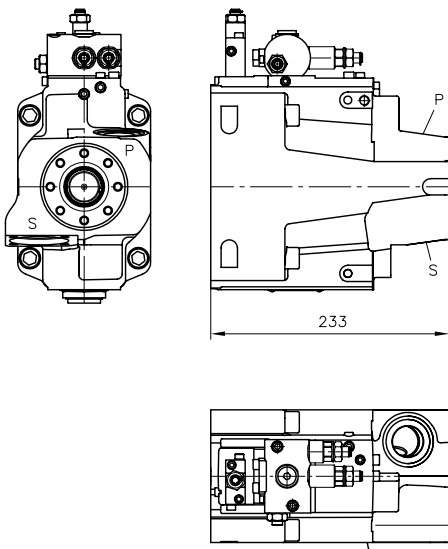

Rotating direction **anti-clockwise**

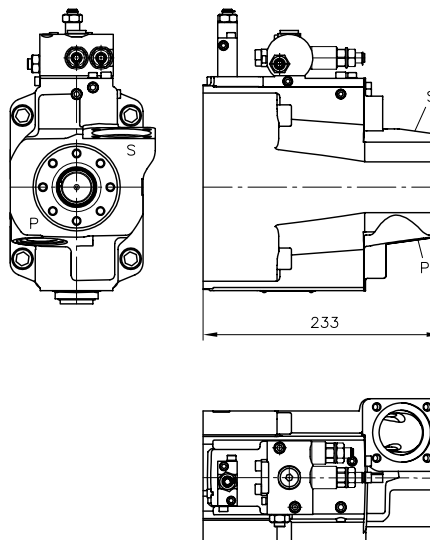

Flange version (output side)

Coding C 030
(ISO 7653-1985)

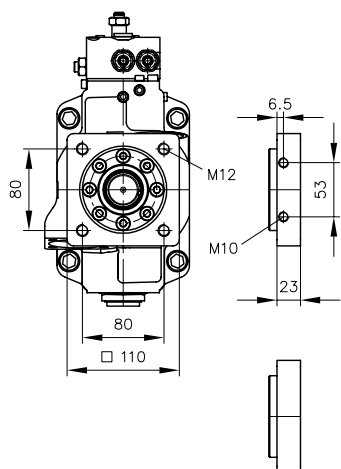

Coding C 031, C 032
(SAE-A 2-hole)

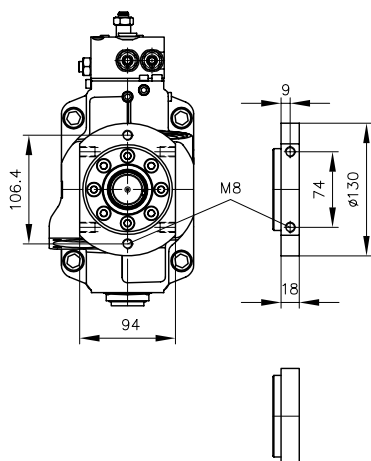

Coding C 034
(SAE-B 2-hole)

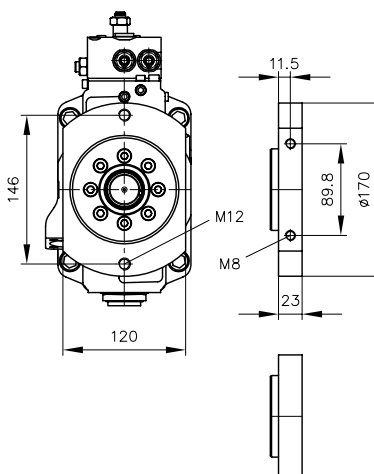

Coding C 035
(SAE-B 4-hole)

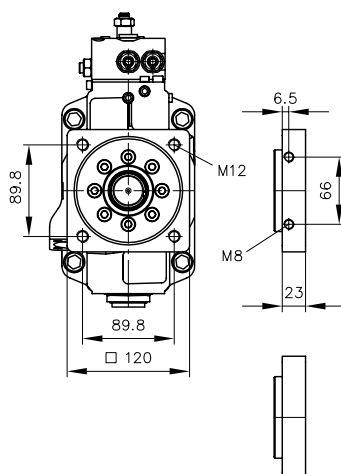

Coding C 038
(SAE-C 4-hole)

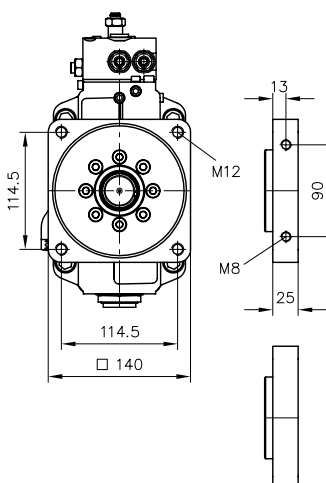

Housing version -3 (radial ports)

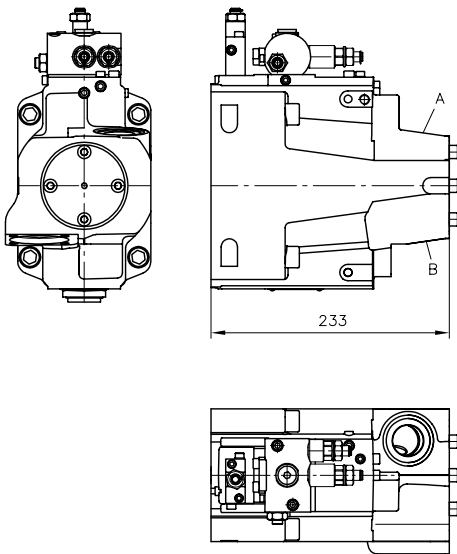

Rotating direction clockwise

A = pressure port

B = suction port

Rotating direction anti-clockwise

A = suction port

B = pressure port

4.2 Controllers and intermediate plates

Coding **LSNR, LSNRT, NXR**

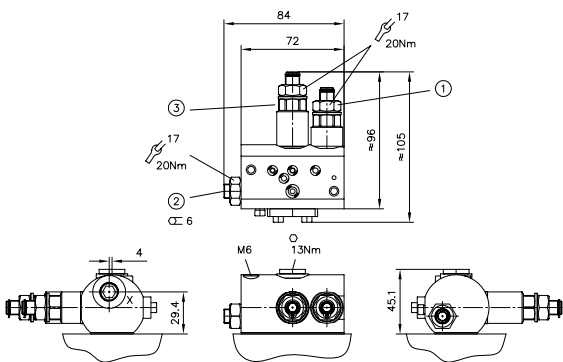

- 1 Pressure limitation
- 2 Dynamic throttle
- 3 Differential pressure Δp (stand-by pressure) (only codings LSNR and LSNRT)

Port X (ISO 228/1 (BSPP)): G 1/4

LS signal port, order reference for adapter for UNF thread 79.93 245

Adjustment range for ② and ③ restricted by retaining ring

Coding **NR**

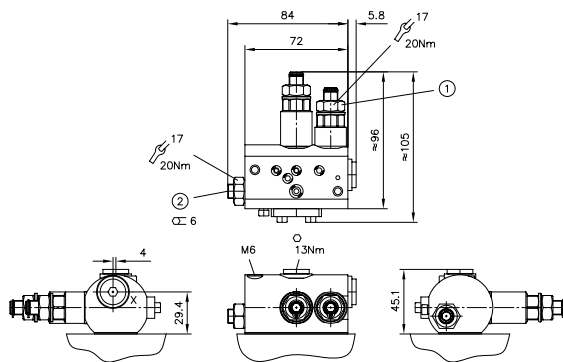

- 1 Pressure limitation
- 2 Dynamic throttle

Coding **QNR**

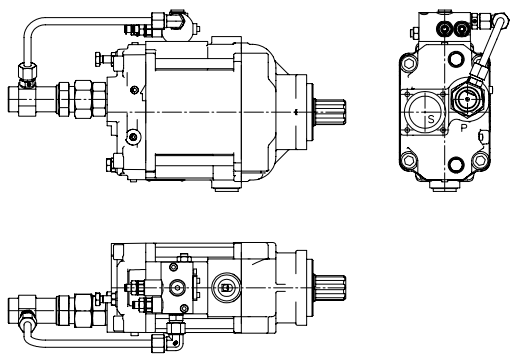

Note

The piping varies depending on the size.

Coding **/PR**

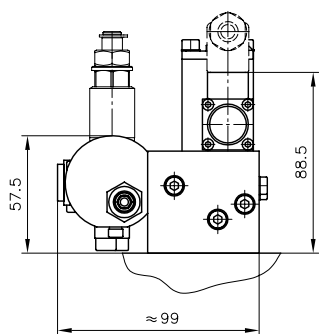

Coding **/P1R**

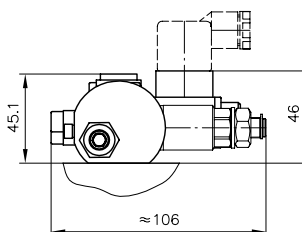

Coding **/V, /V1**

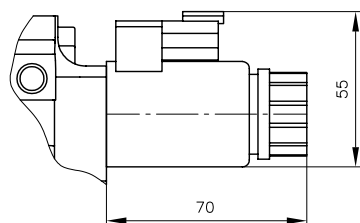

Coding **/L** (only for type V60N-130)

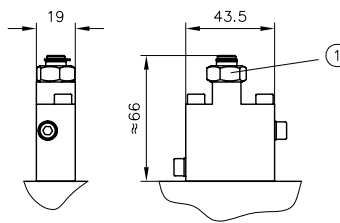

1 Torque setting

Intermediate plates

Version with thru-shaft, coding **/ZW**

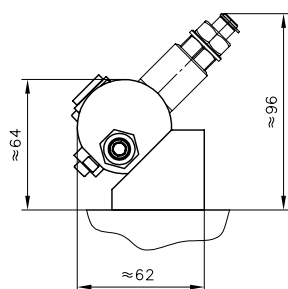

Coding /ZL
Intermediate plates version

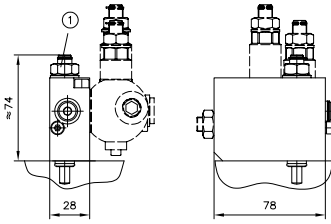

1 Torque setting

Coding /ZV, /ZV1

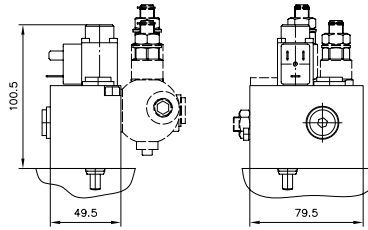

Pressure adjustment

	Pressure range (bar)	Δp (bar) /revolution	Default pressure setting (bar)
Pressure limitation	20 ... 400	approx. 50	300
Differential pressure Δp (only type LSNR)	20 ... 55	approx. 10	27
Differential pressure Δp (only type QNR)	20 ... 55	approx. 10	20

Torque setting

	ΔM (Nm) /revolution	Default torque setting (Nm)
Power controller /ZL	Approx. 190	200
Power controller /L	Approx. 190	700



Caution

Risk of injury on overloading components due to incorrect pressure settings!

- Always monitor the pressure gauge when setting or changing the pressure.

5 Installation information

5.1 General information

The V60N variable displacement axial piston pump is designed for use in an open circuit.

It can be mounted directly on a truck power take-off (PTO) using a flange in accordance with ISO 7653-1985 or using a flange in accordance with specifications. It is possible to attach a support on the pump flange to reduce the weight torque (not for type V60N-060). The positioning of the bore can be found in [Chapter 4, "Dimensions"](#).

Further connection options are available with a cardan shaft and suitable coupling sleeves (see [Chapter 7, "Accessories, spare parts and separate components"](#))

A change of rotating direction is available for types V60N-060, V60N-090 and V60N-110 variable displacement axial piston pumps. For conversion instructions, please contact HAWE Hydraulik SE.

The following essential points must be noted when installing the pump:

Mounting and removal of the pump and attached components may be performed by trained persons only. Ensure absolute cleanliness during all work. Contamination may have an adverse effect on the function and lifetime of the pump.

- Remove all plastic plugs prior to initial operation.
- Avoid installing the motor above the tank (see Installation positions" in [Chapter 5.3, "Installation positions"](#)).
- Observe the reference values in Section [Chapter 7, "Accessories, spare parts and separate components"](#) .
- Prior to initial operation, fill the pump with oil and bleed. Automatic pump filling via the suction line by opening the drain ports is not possible.
- Prevent the pump and suction line from running dry.
- Always ensure a constant supply of oil. Even a brief shortage in the supply of hydraulic fluid to the pump may damage internal parts. This may not be immediately evident after initial operation.
- The hydraulic oil returning to the tank from the system must not be sucked back in immediately (baffles).
- Run the pump for approx. 10 minutes at max. 50 bar after initial operation.
- Thorough bleeding/flushing of the entire system is recommended before the full pressure range is used.
- Observe the max. permissible operating range temperatures (see [Chapter 3, "Parameters"](#)) at all times.
- Always comply with the specified oil purity classes (see [Chapter 3, "Parameters"](#)); provide appropriate hydraulic fluid filtering.
- Use of a filter in the suction line must be approved by HAWE Hydraulik.
- Include a main pressure-limiting valve in the pressure line to limit the max. system pressure.

5.2 Ports

The nominal diameter of the connecting lines depends on the specified operating conditions, the viscosity of the hydraulic fluid, the start-up and operating temperatures and the rotation speed of the pump. In principle we recommend the use of hose lines due to the superior damping characteristics.

Pressure port

The pressure port connection on type V60N-060 is established via a threaded connection G 3/4" (BSPP); on type V60N-090/110/130 via a threaded connection G 1" (BSPP).

Observe the tightening torque specified by the fitting manufacturer.

Suction port

The suction port on all pumps is established via standardised suction intakes with a size that is dependent on the max. delivery flow of the pump.

The specifications of the max. delivery flow Q_{max} must be observed. These can be found in the following table.

Nominal width (N)	38 (1 1/2")	42	50 (2")	64 (2 1/2")	74 (3")	6 (G 1 1/4)	7 (G 1 1/2)
Q_{max} (lpm)	75	90	125	190	250	90	125

The suction intakes can be ordered as an option with the pump.

If possible, route the suction line to the tank in such a way that it is steadily rising. This allows trapped air to escape. Observe the specifications in "Installation positions" [Chapter 5, "Installation information"](#). The absolute suction pressure must not fall below 0.85 bar. A hose line should generally be used in preference to a rigid pipe.

Drain port

The V60N pumps have 2 drain ports G 3/4" (BSPP) or 1 1/16-12-UN-2B. A G 1/8" (BSPP) threaded connection is also available for the flange version SAE-B2, SAE-B4 and SAE-4. This is used for bleeding in the case of vertical installation positions.

The nominal diameter of the leakage line must not be less than 16 mm. The cross-section is determined by the max. permissible housing pressure.

Integrate the leakage line in the system in such a way as to prevent direct connection with the suction line of the pump. Both drain ports can be used simultaneously.

A separate leakage line from the controller to the tank is not required. Observe the specifications in [Chapter 5.3, "Installation positions"](#).

LS port for version LSNR, LSNRT, NXR

The LS line is connected to the controller via a G 1/4" (BSPP) threaded connection.

The nominal diameter of the line depends on the installation position of the pump and should be 10% of the pressure line nominal volume. A hose line should generally be used in preference to a rigid pipe.

- When the proportional directional spool valve is in a neutral position, the LS line must be fully relieved (only controller type LSNR, LSN). In the case of controller type LSNRT, relief takes place internally in the controller.

5.3 Installation positions

The variable displacement axial piston pump V60N can be installed in any installation position.

Observe the truck manufacturer's specifications if installing the pump directly on a truck power take-off.

A support is required for tandem pumps or two hydraulic pumps mounted in series. The following points must be observed:

Horizontal installation: (pump below the min. fill level)

For horizontal installation, use the uppermost drain port.

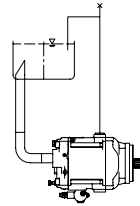
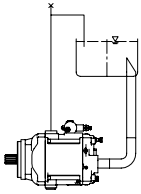

Vertical installation: (pump below the min. fill level)

Mount the pump so that the pump mounting flange is facing upwards. Only pumps with mounting flanges of type SAE-B2, SAE-B and SAE-C are approved for vertical installation. For vertical installation, use the uppermost drain port. Also connect the G 1/4" (BSPP) bleeding port on the pump flange. Take appropriate measures to ensure continuous bleeding of this line (line routing/bleeding). For installation with the pump flange facing downwards, please contact HAWE Hydraulik.

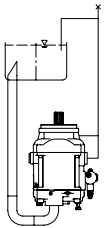

5.4 Tank installation

Tank installation (pump below the min. fill level)

The pump can be operated either with or without a suction tube. Using a short suction intake is recommended.

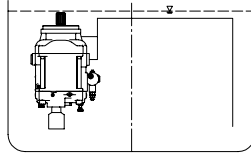
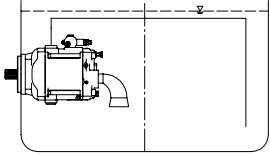

Additional notes regarding installation above the fill level

Special measures are required if the pump is installed above the fill level. The pump must not run dry via the pressure, intake, drain, bleed or control lines. This applies in particular to long periods of downtime.

- The leakage line must be installed in the tank in such a way that it ends below the oil level.
- Facilitate bleeding of connecting lines via separate bleed openings.
- Adjust the bleeding sequence to the specific installation.
- If necessary, a gear pump should be provided in order to draw air from the suction line.

For specialist advice on designing axial piston pumps, the following contact form is available:
[Checklist for designing variable displacement axial piston pumps: B 7960 checklist.](#)

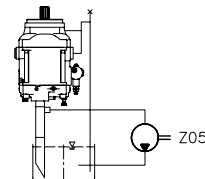
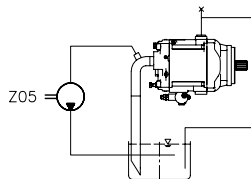
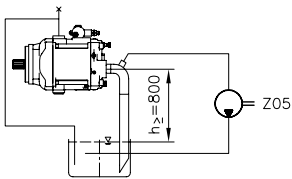

For further information on installation, operation and maintenance, see the relevant assembly instructions:
[B 7960](#), [B 5488](#).

6

Installation, operation and maintenance information

6.1 Designated use

This fluid-power product has been designed, manufactured and tested using standards and regulations generally applicable in the European Union and left the plant in a safe and fault-free condition.

To maintain this condition and ensure safe operation, operators must observe the information and warnings in this documentation.

This fluid-power product must be installed and integrated in a hydraulic system by a qualified specialist who is familiar with and adheres to general engineering principles and relevant applicable regulations and standards.

In addition, application-specific features of the system or installation location must be taken into account if relevant.

This product may only be used as a pump within oil-hydraulic systems.

The product must be operated within the specified technical parameters. This documentation contains the technical parameters for various product versions.



Note

Non-compliance will void any warranty claims made against HAWE Hydraulik.

6.2 Assembly information

The hydraulic accumulator must be integrated in the system via state of the art connection components (screw fittings, hoses, pipes, etc.). The hydraulic system must be shut down as a precautionary measure prior to dismounting; this applies in particular to systems with hydraulic accumulators.

6.3 Operating instructions

Product, pressure and/or flow settings

All statements in this documentation must be observed for all product, pressure and/or flow settings on or in the hydraulic system.



Caution

Risk of injury on overloading components due to incorrect pressure settings!

- Always monitor the pressure gauge when setting or changing the pressure.

Filtering and purity of the hydraulic fluid

Soiling in the fine range, e.g. abraded material and dust, or in the macro range, e.g. chips, rubber particles from hoses and seals, can cause significant malfunctions in a hydraulic system. It is also to be noted that new hydraulic fluid "from the drum" does not necessarily meet the highest purity requirements.

For trouble-free operation pay attention to the purity of the hydraulic fluid (see also purity class in [Chapter 3, "Parameters"](#)).

For further information on installation, operation and maintenance, see the relevant assembly instructions:

[B 7960](#), [B 5488](#).

7 Accessories, spare parts and separate components

7.1 Discontinued controller units

7.1.1 Available versions

Controller

Coding	Description
LSN	Load-sensing controller with integrated pressure limitation
N	Pressure controller, adjustable directly at the pump. The pressure controller automatically maintains a constant system pressure independently of the required delivery flow. Therefore it is suited to constant pressure systems where differing delivery flows are required or for efficient pressure limitation of the hydraulic system.
LLSN	Power controller (torque limitation) in combination with LSN Product "Pressure x Delivery flow" = constant Adjustment range: 25 ... 100% max. drive torque
LN	Power controller (torque limitation) in combination with pressure controller N Adjustment range: 25 ... 100% max. drive torque

Switching symbols

Coding LSN

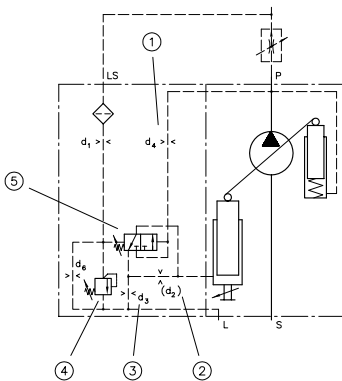

- 1 Inflow orifice
- 2 By-pass orifice (option)
- 3 Outflow orifice
- 4 Pressure limitation p_{max}
- 5 Differential pressure p

Coding LLSN

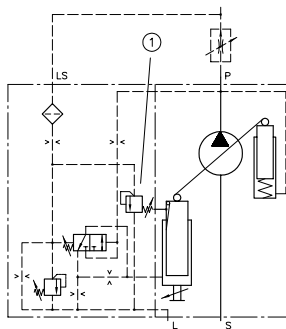

- 1 Power controller

Coding N

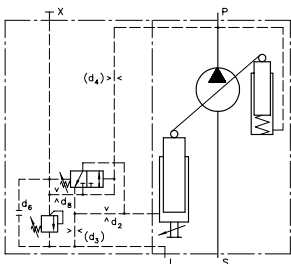

Coding LN

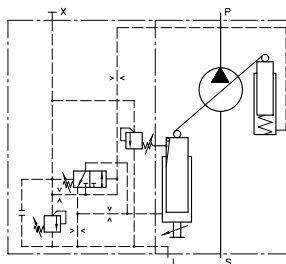

Fitted orifices (standard)

Controller	$\varnothing d_1$	$\varnothing d_2$	$\varnothing d_3$	$\varnothing d_4$	$\varnothing d_6$	$\varnothing d_8$
LSN LLSN	0.9	-	0.7	1.2	2x0.4	-
N LN	-	0.7	-	-	-	0.7

Unit dimensions

Type LSN, LN, N and LLSN

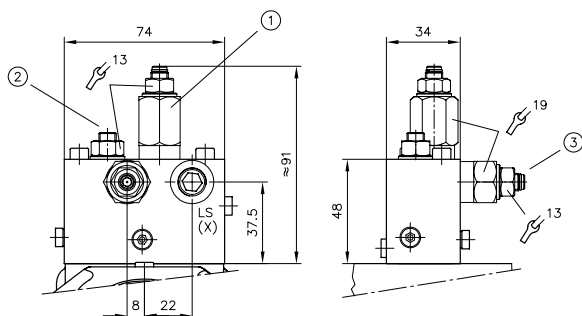

- 1 Pressure differential Δp (only controller LSN and LLSN)
- 2 Power setting
- 3 Pressure limitation

LS signal port
Port (ISO 228/1 (BSPP)):
LS = G 1/4

Order reference for adapter
for UNF thread 79.93 245

Pressure adjustment

	Pressure range (bar)	Δp (bar) /revolution	Default pressure setting (bar)
Pressure limitation	50 ... 400	100	300
Differential pressure Δp (type LSN and LLSN)	18 ... 45	10	27



Caution

Risk of injury on overloading components due to incorrect pressure settings!

- Always monitor the pressure gauge when setting or changing the pressure.

7.2 Suction intakes

Order coding example:

V60N - 090 R DZ N - 1 - 0 - 01/LSNR - 350 - **A00/76**

Table of suction intakes (including attachment kit)

Nominal width (N)	Flow Q_{max} (lpm)	Geometric shape									
		Straight		45°		90°		Thread A.	Order number		
		A00/..	Order number	A45/..		A90/..					
		h		h	k	h	k	h			
38 (1 1/2")	75	65	79 93336 00	-	-	-	53	70	79 93344 00	-	-
42	90	-	-	85	40	79 93340 00	-	-	-	-	-
50 (2")	125	65	79 93337 00	96	40	79 93341 00	53	84	79 93345 00	-	-
64 (2 1/2")	190	90	79 93338 00	96	40	79 93342 00	109	129	79 93346 00	-	-
76 (3")	250	106	79 93339 00	106	40	79 93343 00	-	-	-	-	-
7 (1 1/2")	125	-	-	-	-	-	-	-	-	28.5	79 40717 00
7 UNF (1-7/8-12 UN-2B)	125	-	-	-	-	-	-	-	-	28.5	79 41595 00

A00/...

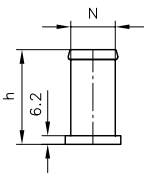

45/...

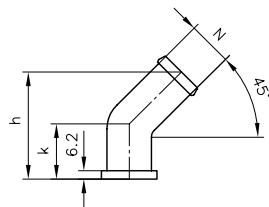

A90/...

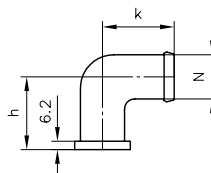

A6
A7

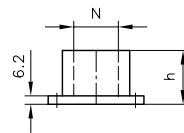

Delivery includes attachment kit for suction intakes, comprising:

- 4x hex bolt M8x16-8.8
- Sealing ring 44.2x3 NBR 70 Sh
- 2 mounting flange halves

(Order no. 79 93355 00)



Note

Use nominal width 38 (1 1/2") for reduced displacement volume only!

Observe installation information in [Chapter 5, "Installation information"](#).

7.3 Coupling flange for propshafts

Special coupling flanges for propshafts ($\varnothing 100-6-\varnothing 8$) according to ISO 7646.

For telescopic propshafts also with spacer ring and connecting screw for attachment to the drive shaft of the pump.

Coding SAE-C, SAE-CS

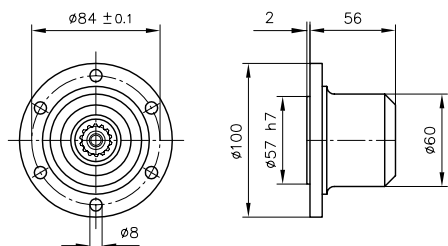

Coding DIN ISO 014

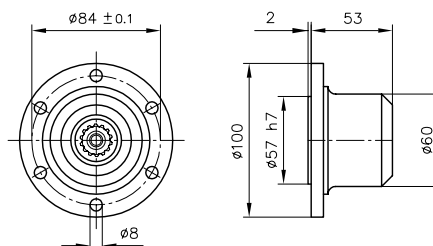

Coding	Spline profile	Order number
SAE C	14T 12/24 DP	79 29555 00
SAE CS	21T 16/32 DP	79 42793 00
DIN ISO 14	B8x32x36	79 29709 00

Special clampable coupling flanges for propshafts ($\varnothing 100-6-\varnothing 8$) according to ISO 7646.

Coding	Spline profile	Order number
SAE-C	14T 12/24 DP	79 94495 00
SAE-CS	21T 16/32 DP	79 94479 00
DIN ISO 14	B8x32x36	79 94496 00

Coding SAE-C, SAE-CS, DIN ISO 014

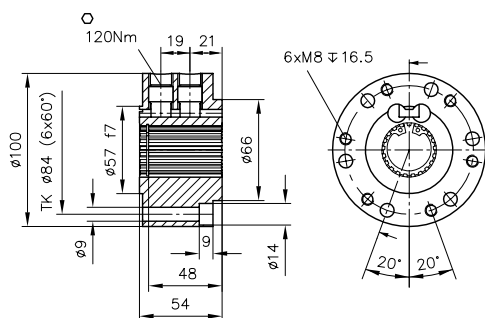

Additional versions

- General operating manual for the assembly, initial operation and maintenance of hydraulic components and systems: B 5488
- Variable displacement axial piston pump type V40M: D 7961
- Variable displacement axial piston pump type V30D: D 7960
- Variable displacement axial piston pump type V30E: D 7960 E
- Fixed displacement axial piston pump type K60N: D 7960 K
- Axial piston motor type M60N: D 7960 M
- Proportional directional spool valve, type PSL and PSV size 2: D 7700-2
- Proportional directional spool valve, type PSL, PSM and PSV size 3: D 7700-3
- Proportional directional spool valve, type PSL, PSM and PSV size 5: D 7700-5
- Proportional directional spool valve type PSLF, PSVF and SLF size 3: D 7700-3F
- Proportional directional spool valve type PSLF, PSVF and SLF size 5: D 7700-5F
- Proportional directional spool valve banks type PSLF and PSVF size 7: D 7700-7F
- Load-holding valve type LHT: D 7918
- Load-holding valve type LHDV: D 7770
- Proportional amplifier type EV1M3: D 7831/2
- Proportional amplifier type EV1D: D 7831 D