

Directional spool valves type HSF

manifold mounting, electro-hydraulically actuated for oil-hydraulic systems

Operating pressure p_{max} = 400 bar
Flow Q_{max} = 80 and 160 lpm

1. General

This pamphlet is a supplement to D 7493 covering the directional spool valve banks type HSR. The individual valves for manifold mounting described here share the same functional principle, directional seated pilot valves and optional thread-type throttles for switching time adjustment, as outlined in the basic pamphlet D 7493. The switching time adjustment is detailed also there. The required manifolds are customer furnished, as they are not available from HAWE.

Important: The valve has two outlet ports R (see dimensional sketches). Both must be connected at the manifold, but may be internally joined there.

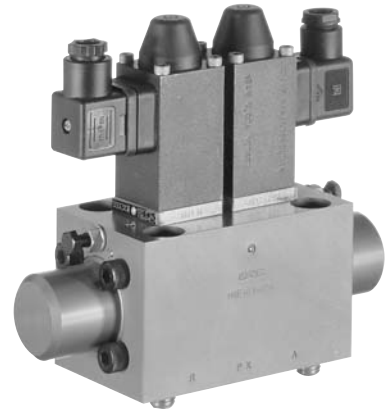

2. Types available, main data

Order example:

HSF 3 G - G 24

Table 1: Basic type and size

Coding	HSF 3	HSF 4
Nominal size appr.	NG 12	NG 16
Flow Q_{max} (lpm)	80	160
Pressure p_{max} (bar)	400	

Table 3: Pilot valve

Solenoid actuated via pilot valve type WN 1 H (for missing data, see D 7470 A/1)				Without pilot valve, for hydraulic remote control
Standard, with plug	Without plug	With plug featuring LED's	Nom. voltage	
G 12	X 12	L 12	12 V DC	X
G 24	X 24	L 24	24 V DC	See section 5.1
G 98	X 98	---	98 V DC	
G 205	X 205	---	205 V DC	
WG 110	---	---	110 V AC 50 /	
WG 230	---	---	230 V AC 60 Hz	

Table 2: Symbols

		Valve with blocked middle position, suitable for connection in parallel						Valve with middle position P → R (circulation), suitable for connection in series			Attention: When several valves are connected in series, note that when the H(1) and F(1) valves are in their zero position, outlets connected to R are pressurized when a downstream valve is operated.
Switching time adjustment	without	G	D	E	C	W	B	L	H	F	
	with 1)	G 1	D 1	E 1	C 1	W 1	B 1	L 1	H 1	F 1	
Simplified symbol 2)	a 0 b										

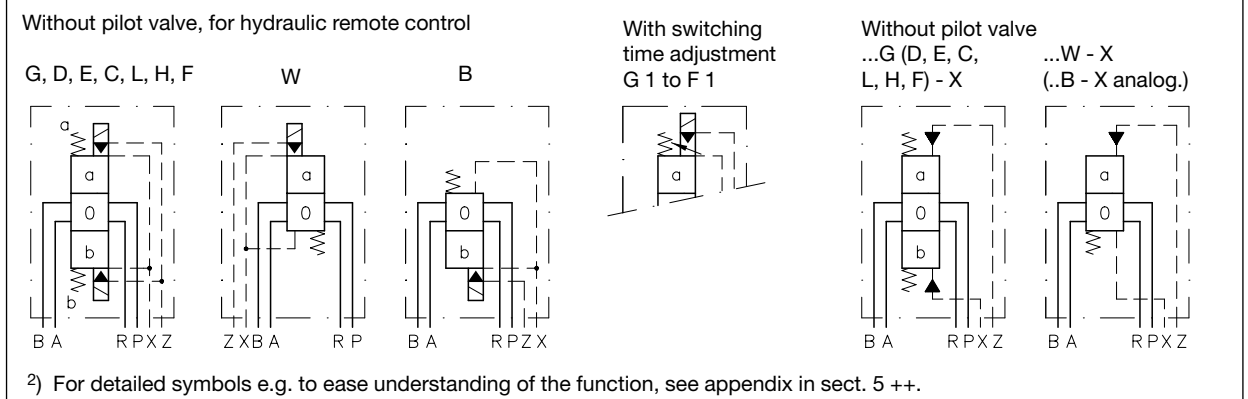

3. General parameter

Type and version	Directional spool valve, full steel design. Housing zinc galvanized, giving a good resistance to corrosion. Valve spools hardened, ground and polished/deburred. Together with the diamond-honed and polished and deburred housing bore, this gives an exactly circular and even sealing gap with a minimum leakage rate. Built-on directional ball seated valves type WN 1 H acc. to D 7470 A/1 as pilot valves
Installation position	Any
Line connection	Via manifold, customer-furnished, as not available from HAWE
Port coding	P = Pump inlet R = Return. Important: 2 ports! (exception coding C, see section 5.1) A, B = Consumers Z = Control oil inlet X = Control oil outlet (tank) Control oil outlet (tank) for version with solenoid actuation = Control oil inlet for version X with hydraulic remote control (table 3) at position a with 4/3-way directional spool valves (see sect. 5.1)
Overlapping	Zero
Switching time (guideline figures)	Without switching time adjustment (not throttled) HSF 3: $t_{on} = 30...40$ ms; $t_{off} = 70...100$ ms HSF 4: $t_{on} = 50...60$ ms; $t_{off} = 110...140$ ms
Mass (weight)	HSF 3 = 2.8 kg HSF 4 = 5 kg
Flow	HSF 3 = 80 lpm HSF 4 = 160 lpm
Pressure	P, A, B, and R = 400 bar; Z and X = 160 bar
Control pressure	Max. 160 bar, min. 10 bar; optimum operation at 15... 40 bar, either from own control circuit or via a pressure control valve ADC 1-25 (e.g. housed in base plate, see circuit examples, section 5.2). Refer to notes on flow diagrams L, F and H in example 3.
Control volume	HSF 3 = approx. 1.8 cm ³ HSF 4 = approx. 5 cm ³
Surface	Nitrided
Hydraulic fluid	Fluids conf. DIN 51524 table 1 to 3; ISO VG 10 to 68 conf. DIN 51519 Viscosity range: min. approx. 4; max. approx. 1500 mm ² /sec Optimal operation range: approx. 10...500 mm ² /sec Also suitable are biologically degradable pressure fluids of the type HEPG (Polyalkylenglycol) and HEES (synth. Ester) at operation temperatures up to approx. +70°C.
Temperature	Ambient: approx. -40...+80°C Fluid: -25...+80°C, pay attention to the viscosity range! Start temperature down to -40°C are allowable (Pay attention to the viscosity range during start!), as long as the operation temperature during subsequent running is at least 20 K (Kelvin) higher. Biological degradable pressure fluids: Pay attention to manufacturer's information. With regard to the compatibility with sealing materials do not exceed +70°C.
Pilot valves (Type WN 1 H acc. to D 7470 A/1)	At 60°C ambient temperature not over 60 % duty cycle, at 80°C not over 35% duty cycle. The heat generation of the solenoid can be decreased by reducing the supply voltage. This gives some safety margin as a balance for increased ambient temperatures and greater safety under normal conditions at possibly changing ambient temperatures Control pressure ≤ 160 bar $\rightarrow U_{reduc.} = 0.75 U_{nom}$, permissible ambient temperature 60°C Control pressure 35 bar $\rightarrow U_{reduc.} = 0.5 U_{nom}$, permissible ambient temperature 80°C

Δp -Q-curves

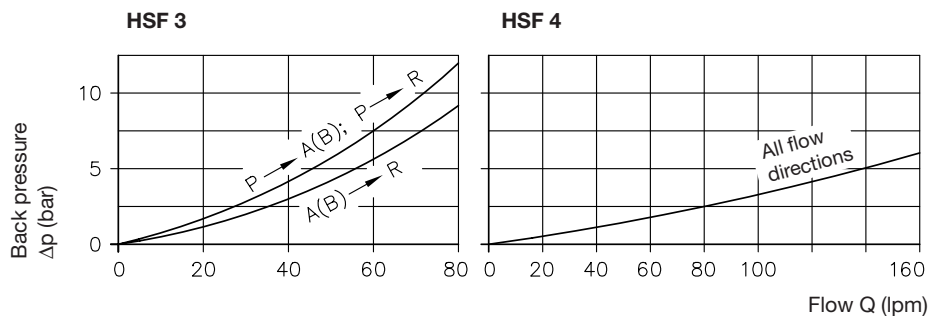

4. Unit dimensions

All dimension in mm and subject to change without notice!

Type HSF 3...

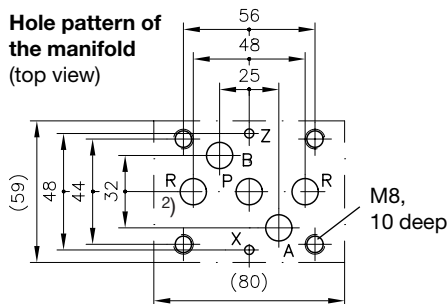
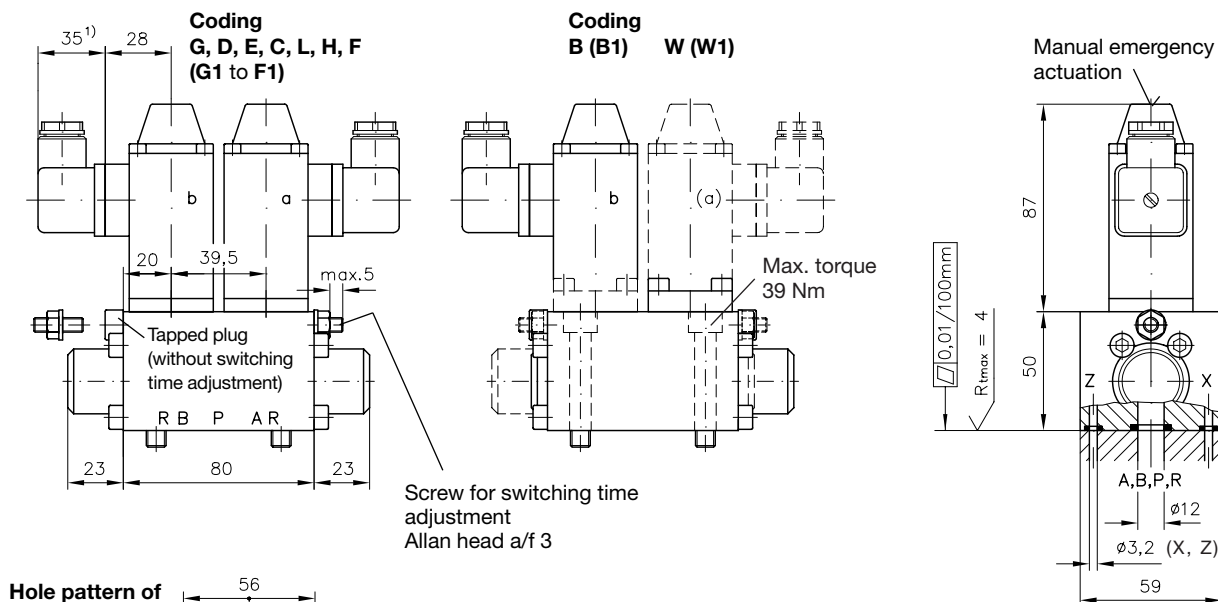

Ports	Sealing of the flange area via O-ring NBR 90 Sh
A, B, P, R	13.95x2.62
X, Z	3.7x1.78

Manual emergency actuation

Actuation aid (do not use any sharp-edged tools)

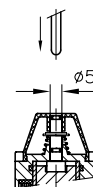

Type HSF 4...

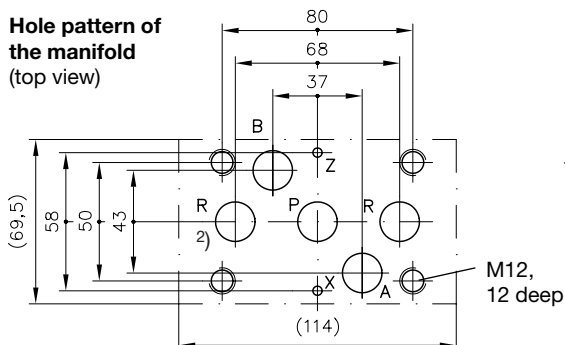
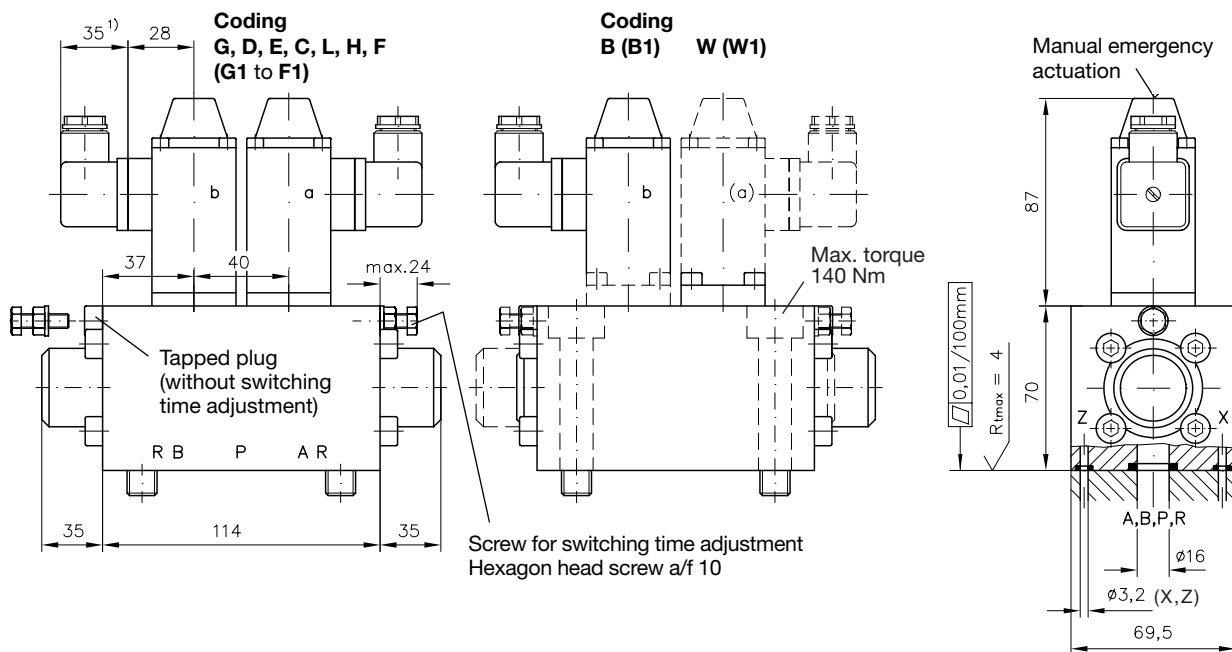

Ports	Sealing of the flange area via O-ring NBR 90 Sh
A, B	18.75x2.62
P, R	20.29x2.62
X, Z	4.47x1.78

1) This dimension is depending on the manufacturer and may be up to max. 40 mm (conf. DIN EN 175 301-803)

2) Not present with codes C, C1

5. Appendix

5.1 Detailed flow symbols

Examples not listed should be drawn accordingly. Control port X serves as drain/leakage port to the tank with spools W1 and B1.

Standard version with pilot valves

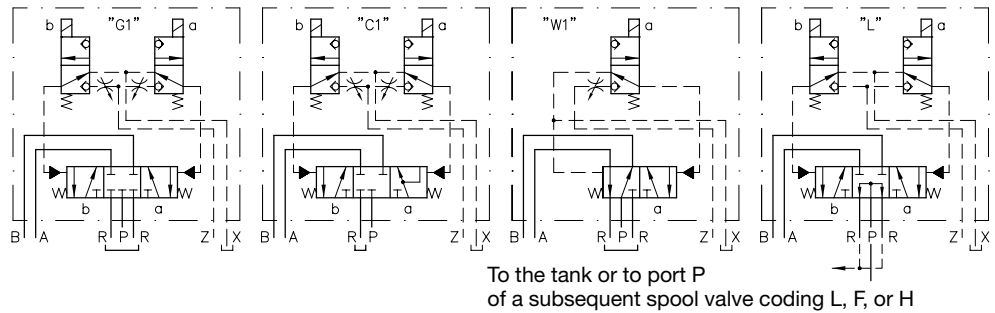

Version ...-X, without pilot valve

In the case of 4/3-way versions with switching time adjustment (e.g. G1, D1 etc.), only the control port Z can be influenced via the throttle screw. In the case of control port X, it is necessary to install a throttle (e.g. FG or FG-S 6 acc. to D 7275) externally into the connected control line. The symbol illustration opposite, applies to valve coding G and W and analogously to D, E, C, B, L, H, and F.

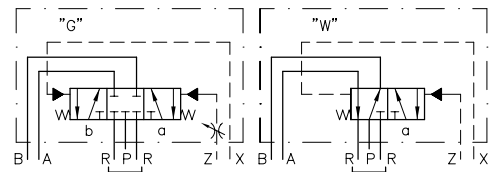

5.2 Circuit examples

The illustrated manifolds are not scope of delivery!

Example 1:

Most simple control with directional spool valves suited for parallel connection. Control oil pick-up and return is internal in the manifold. Permissible pressure is approx. 160 bar (see control pressure in sect. 3) and when no pressure surges (decompression surges) are expected in the return line.

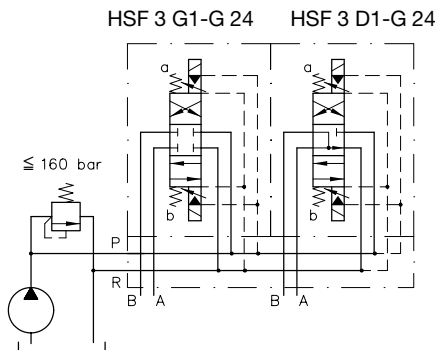

Example 2:

Same control task as example 1, but with control oil pick-up from a pressure circuit >160 bar. The pressure for the control oil circuit is reduced down to approx. 30 bar here via pressure reducing valve type ADC 1-25 screwed into the manifold, see D 7458 for mounting hole details). It is recommended to provide an additional gallery for the control oil return (as illustrated), when pressure surges are expected in the main return line.

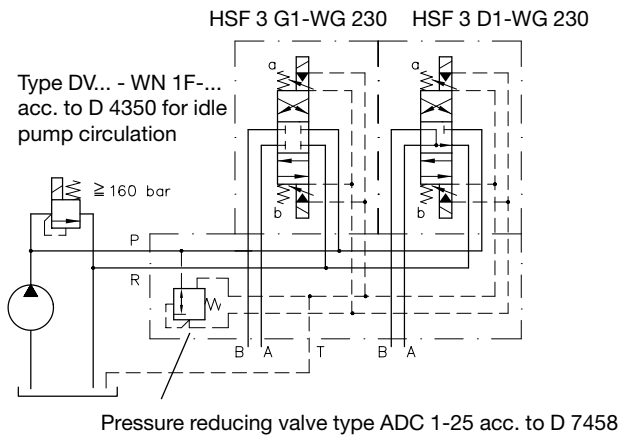

Example 3:

A direct control oil pick-up from the pump pressure line is not possible in most cases with flow pattern symbols L, H, and F as the back pressure in idle position does not exceed the minimum control pressure required for switching operations (particularly if there is only one single valve). It is therefore recommended to employ a pump, e.g. type R acc. to D 6010 S feeding a separate control oil circuit (see example). Another way is to use a completely separate control circuit pump, i.e. gear pump with approx. 0.5...1 lpm, limited to approx. 20 bar, making an ADC 1-25 superfluous. Otherwise, pay attention to the summation of the back pressure, particularly when several valves are connected in series.

