

Direct current compact hydraulic power pack type NPC

Product documentation



For short-term and standby mode

Operating pressure p_{\max} : 750 bar

Geometric displacement V_{\max} : 0.46 cm³/rev

Usable volume V_{use} : 0.65 l

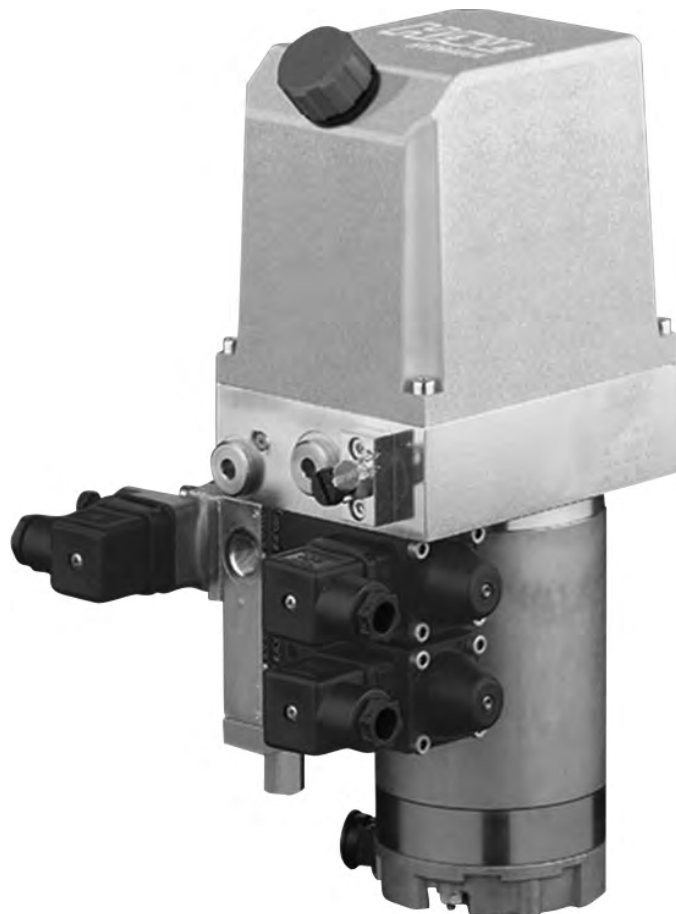

© by HAWE Hydraulik SE.

The forwarding and reproduction of this document, as well as the use and communication of its contents, are forbidden unless expressly permitted.

Any breach or infringement will result in liability for damages.

All rights reserved concerning patent or utility model registrations.

Contents

1	Overview compact hydraulic power pack type NPC.....	4
2	Available versions, main data.....	5
3	Parameters.....	9
3.1	General, hydraulic and electrical.....	9
4	Dimensions.....	11
5	Installation, operation and maintenance information.....	12
5.1	Designated use.....	12
5.2	Assembly information.....	12
5.3	Operating instructions.....	13
5.4	Maintenance information.....	13

Compact hydraulic power packs are a type of hydraulic power pack. They are characterised by a highly compact design, since the motor shaft of the electric motor also acts as the pump shaft.

The ready-for-connection compact hydraulic power pack type NPC is suitable for hydraulic systems with operating mode S2. Type NPC includes a DC motor. The power pack is available in a horizontal or vertical version. Either single-circuit systems or dual-circuit systems can be selected. A radial piston pump or an external gear pump can be used as a hydraulic pump.

The compact hydraulic power pack type NPC is suitable for use as a highly compact control system, since the pressure-limiting valve is integrated and valve banks can be directly mounted.

Features and benefits:

- Very low space requirements and easy to transport
- Supplied with direct current at 12V DC or 24V DC
- Particularly suited to mobile applications and construction site operation
- Long service life and excellent reliability achieved by using radial piston pumps
- Environmentally sound thanks to low oil fill volumes and minimum amount of oil to be disposed of
- Low costs for hydraulic fluid
- Co-ordinated range of valves and accessories from the modular system

Intended applications:

- Riveting
- Brakes for wind power plants
- Hydraulic jigs
- Crimping
- Embossing

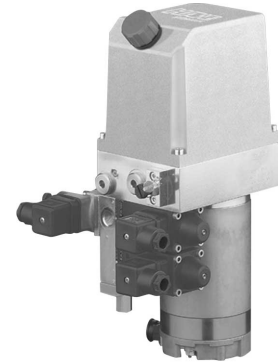
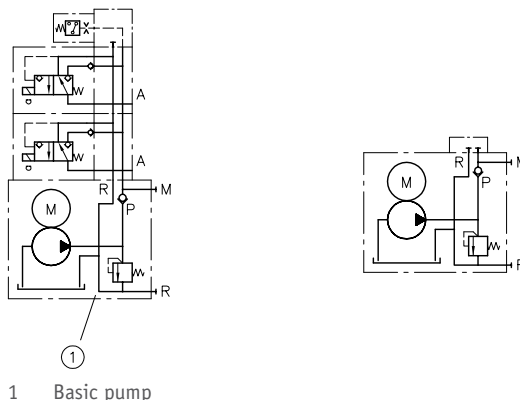

Figure 1: Compact hydraulic power pack type NPC

2 Available versions, main data

Circuit symbol:



Order coding example:

NPC 11	/0,31	- 1/320	- R	- 24	- BWH 1 - NN - 33 - G 24
NPC 12	/0,4	- 2/750	- R	- 12	- BWH 1 - 1

Attachments Table 6 Attachments

Motor voltage Table 5 Motor voltage

Check valve Table 4 Check valve

Pressure-limiting valve with pressure setting Table 3 Pressure-limiting valve with pressure setting

Delivery flow coding Table 2 Delivery flow coding

Basic type and size Table 1 Basic type and size

Table 1 Basic type and size

Coding	Description	Nominal power Approx. (kW)
NPC 11	Vertical version	0.3
NPC 12		0.6
NPC 11 L	Horizontal version	0.3
NPC 12 L		0.6

Table 2 Delivery flow coding
Version with radial piston pump

Coding		Output volume V_g (cm ³ /rev)	No-load flow Q_0 (lpm)	Operating pressure p_{max} (bar)
NPC 11	0,2	0.09	0.27	750
	0,31	0.14	0.42	640
	0,44	0.20	0.59	450
	0,61	0.28	0.83	320
	0,87	0.36	1.07	250
	1.05	0.46	1.36	190

Version with gear pump

Coding		Output volume V_g (cm ³ /rev)	No-load flow Q_0 (lpm)	Operating pressure p_{max} (bar)
NPC 11	Z 0,5	0.18	0.5	180
	Z 0,7	0.25	0.7	200
	Z 0,9	0.32	0.9	200
	Z 1,1	0.4	1.1	200
	Z 1,4	0.5	1.4	200
	Z 1,7	0.63	1.7	180
	Z 1,9	0.7	1.9	160
	Z 2,2	0.8	2.2	140
	Z 2,8	1.0	2.8	110

Version with radial piston pump

Coding		Output volume V_g (cm ³ /rev)	No-load flow Q_0 (lpm)	Operating pressure p_{max} (bar)
NPC 12	0,4	0.15	0.45	750
	0,65	0.24	0.71	660
	0,94	0.34	1.02	470
	1,28	0.46	1.39	350
	1,71	0.6	1.81	270
	2,14	0.76	2.29	210

Version with gear pump

Coding		Output volume V_g (cm ³ /rev)	No-load flow Q_0 (lpm)	Operating pressure p_{max} (bar)
NPC 12	Z 0,5	0.18	0.65	180
	Z 0,7	0.25	0.9	200
	Z 0,9	0.32	1.2	200
	Z 1,1	0.4	1.5	200
	Z 1,4	0.5	1.8	200
	Z 1,7	0.63	2.2	200
	Z 1,9	0.7	2.5	200
	Z 2,2	0.8	2.9	200
	Z 2,8	1.0	3.5	180

Table 3 Pressure-limiting valve with pressure setting

Coding	Note
1/...	Fixed setting
2/...	Adjustable

Table 4 Check valve

Coding	Description
No designation	Without check valve
R	With check valve in P

Table 5 Motor voltage

Coding	Description
G 12	Nominal voltage 12V DC
G 24	Nominal voltage 24V DC

Table 6 Attachments (direct attachment of valve banks)

Coding	Note
Type BWN 1, BWH 1	See documentation D 7470 B/1
Type VB01	See documentation D 7302

3 Parameters

3.1 General, hydraulic and electrical

General information

Description	Constant pump for short period operation with DC motor
Design	Valve-controlled 3-cylinder radial piston pump or gear pump
Installation position	Vertical, horizontal
Ports	In accordance with mounting units
Temperatures	Ambient: approx. -40 to +60°C, oil: -25 to +80°C, pay attention to the viscosity range! Start temperature: down to -40°C is permissible (observe start-viscosity!), as long as the steady-state temperature is at least 20K higher for subsequent operation. Biologically degradable pressure fluids: note manufacturer specifications. With consideration for the seal compatibility, not above +70°C.
Oil filling	Fill volume 1.0 l; usable volume 0.65 l

Pressure and volumetric flow

Operating pressure	Max. 750 bar
Volumetric flow (no load)	See load-dependent characteristic curve below

Electrical

NPC 11

Nominal voltage	U_N	24V	12V
Nominal power	P_N	0.1 / 0.3 kW	0.1 / 0.25 kW
Nominal current	I_N	5.6 / 22 A DC	10.5 / 35 A DC

NPC 12

Nominal voltage	U_N	24V	12V
Nominal power	P_N	0.6 kW	0.6 kW
Nominal current	I_N	35 A DC	70 A DC
Rated rotation speed	n_N	3000 / 2000 rpm	
Protection class		IP 44	
Insulation material class		F	
Electrical connection		2x flat plug 6.3x0.8	
Permissible load duration		1 p_{max}	Duty cycle \leq 10%
		0.5 p_{max}	Duty cycle \leq 20%
		0.3 p_{max}	Duty cycle \leq 30%
Recommended line cross section		2x 4 mm ²	(\leq 35 A)
		2x 6 mm ²	(< 35 A)

Actual current consumption and delivery flow characteristic

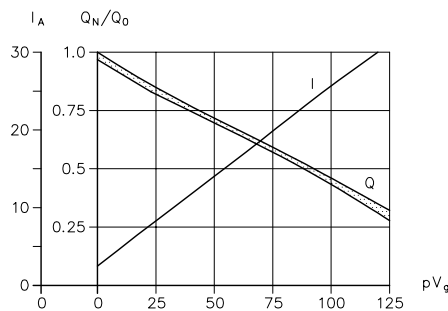

Figure 2: pV_g hydraulic work (bar/cm³); I_A motor voltage (A)

Weight

Type NPC 11	= 6.0 kg
Type NPC 12	= 8.0 kg

4 Dimensions

All dimensions in mm, subject to change!

Vertical version

Example with valve bank type BWN 1 or BWH 1

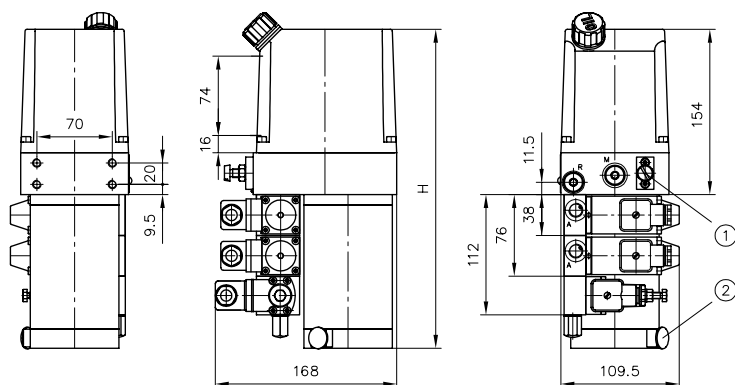

	H
NPC 11	297
NPC 12	357

- 1 pressure-limiting valve
- 2 Electrical connection

Horizontal version H

For dimension see vertical version)

Example with valve bank type BWN 1 or BWH 1.

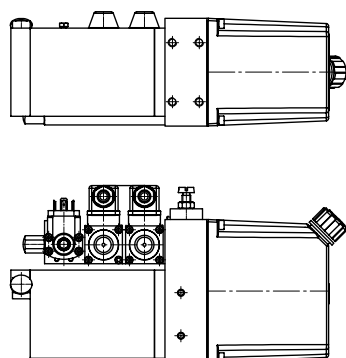

Without valve bank

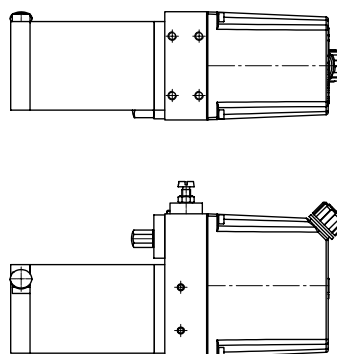

Horizontal version Z

(Dimensions, see vertical version)

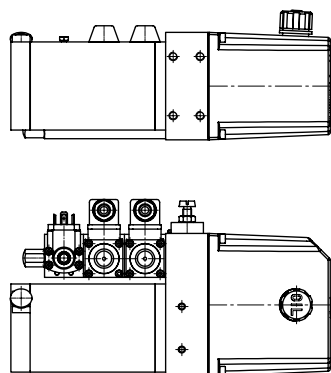

5.1 Designated use

This fluid-power product has been designed, manufactured and tested acc. to standards and regulations generally applicable in the European Union and left the plant in a safe and fault-free condition.

To maintain this condition and ensure safe operation, operators must observe the information and warnings in this documentation.

This fluid-power product must be installed and integrated in a hydraulic system by a qualified staff who is familiar with and observes the general engineering principles and relevant applicable regulations and standards.

In addition, application-specific features of the system or installation location must be taken into account if relevant.

This product may only be used as a pump within oil-hydraulic systems.

The product must be operated within the specified data. This documentation contains the technical parameters for various product versions.

**Note**

Non-compliance will void any warranty claims made against HAWE Hydraulik.

5.2 Assembly information

The hydraulic accumulator must be integrated in the system via state of the art connection components (screw fittings, hoses, pipes, etc.). The hydraulic system must be shut down as a precautionary measure prior to dismantling; this applies in particular to systems with hydraulic accumulators.

5.3 Operating instructions

Product, pressure and/or flow settings

All statements in this documentation must be observed for all product, pressure and/or flow settings on or in the hydraulic system.



Caution

Risk of injury on overloading components due to incorrect pressure settings!

- Always monitor the pressure gauge when setting or changing the pressure.

Filtering and purity of the hydraulic fluid

Soiling in the fine range, e.g. abraded material and dust, or in the macro range, e.g. chips, rubber particles from hoses and seals, can cause significant malfunctions in a hydraulic system. It is also to be noted that new hydraulic fluid "from the drum" does not necessarily meet the highest purity requirements.

For trouble-free operation pay attention to the purity of the hydraulic fluid (see also purity class in [Chapter 3, "Parameters"](#)).

5.4 Maintenance information

This product is largely maintenance-free.

Conduct a visual inspection to check the hydraulic connections for damage at regular intervals, but at least once per year. If external leaks are found, shut down and remedy.

Check the device surfaces for dust deposits at regular intervals (but at least annually) and clean the device if required.

Additional versions

- Valve bank (directional seated valve) type BWN and BWH: D 7470 B/1
- Valve bank (directional seated valve) type VB: D 7302