

# Directly mounted CAN controls

## Product documentation

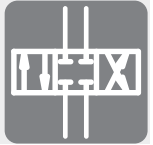

Proportional directional spool valve type PSL and PSV (series connection)  
Proportional directional spool valve type PSLF and PSVF (manifold mounting)

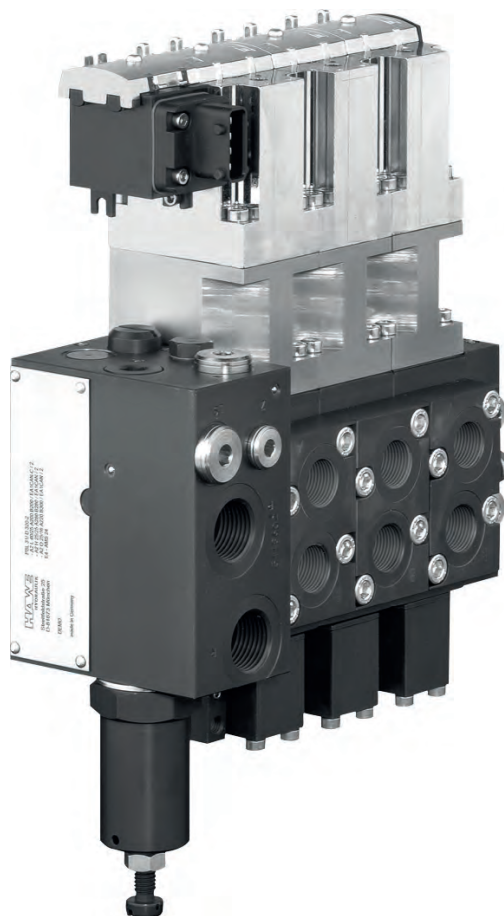

© by HAWE Hydraulik SE.

The forwarding and reproduction of this document, as well as the use and communication of its contents, are forbidden unless expressly permitted.

Any breach or infringement will result in liability for damages.

All rights reserved concerning patent or utility model application.

# Contents

|          |   |           |
|----------|---|-----------|
| <b>1</b> | <b>Overview of directly mounted CAN controls for proportional directional spool valves.....</b> | <b>4</b>  |
| <b>2</b> | <b>Available versions, main data.....</b>   | <b>5</b>  |
| 2.1      | Order coding, structure.....  | 5         |
| 2.1.1    | Combination options.....  | 6         |
| <b>3</b> | <b>Parameters.....</b>  | <b>7</b>  |
| 3.1      | General parameters.....   | 7         |
| 3.2      | Electrical parameters.....  | 7         |
| 3.3      | Acceptance tests and environmental tests.....   | 7         |
| 3.4      | Electrical connection.....  | 8         |
| <b>4</b> | <b>Dimensions.....</b>  | <b>9</b>  |
| 4.1      | Actuation add-on.....   | 9         |
| 4.2      | Structure of valve bank (series connection) – example.....                                      | 10        |
| 4.3      | Structure of valve bank (manifold mounting) – example.....                                      | 11        |
| <b>5</b> | <b>Installation, operation and maintenance information.....</b>                                 | <b>12</b> |
| 5.1      | Designated use.....   | 12        |
| 5.2      | Operating instructions.....   | 12        |
| 5.3      | Maintenance information.....  | 13        |
| 5.4      | Safety instructions.....  | 13        |
| 5.5      | Assembly and installation instructions.....   | 14        |
| 5.6      | CAN bus control unit.....   | 15        |
| 5.7      | Structure of the CAN actuation head.....  | 17        |
| 5.8      | CAN starter set.....  | 17        |

# 1 Overview of directly mounted CAN controls for proportional directional spool valves

Proportional directional spool valve banks are used to control the direction of movement and the infinite adjustment of the movement speed of the hydraulic consumers independent of the load. This allows multiple consumers to be run at the same time and independently of each other at different speeds and pressures, as long as the sum of the partial flow rates required for this is covered by the total delivery flow on the pump side. The electrical connection between the valve sections is via internal cable connections (power supply and CAN bus).

## Features and benefits:

- Simple wiring
- In-built displacement transducer
- Calibrated at the factory ( $i_{\min}$ ,  $i_{\max}$ , etc.)
- Configurable valve characteristics (linearisation, precision control ranges etc.)
- Adjustable ramps
- Increased response characteristics
- Ability to limit maximum flow rate
- Diagnostic capability (fault detection, spool position)

## Intended applications:

- Cranes
- Hydraulic steering systems
- Construction machines
- Lifting devices
- Machines for forestry purposes
- Municipal trucks

## Versions:

- Actuation option for sizes 2, 3 and 5 (series connection)
- Actuation option for size 3 (manifold mounting)

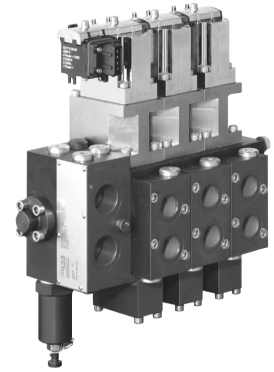

Figure 1: Valve bank in series connection

## 2 Available versions, main data

### 2.1 Order coding, structure

Order coding example:

|                |              |                   |                              |                |      |      |  |
|----------------|--------------|-------------------|------------------------------|----------------|------|------|--|
| PSV 31/D 170-2 | -A 2 J 25/25 | /EA<br>/EA<br>/EA | <b>CAN-C</b><br>CAN<br>CAN-E | /2<br>/2<br>/2 | -E 4 | -AMP | <b>-O-PLVC/250</b>                                       |
|                |              |                   |                              |                |      |      | <b>CAN protocol</b> Table 4 CAN protocol                 |
|                |              |                   |                              |                |      |      | <b>Connector</b> Table 3 Connectors                      |
|                |              |                   |                              |                |      |      | <b>CAN actuation add-on</b> Table 2 CAN actuation add-on |
|                |              |                   |                              |                |      |      | <b>Electrical actuation</b> Table 1 Electrical actuation |

The type codings in bold are described in this document. For all other details, please see [D 7700-2](#), [D 7700-3](#) and [D 7700-5](#)

**Table 1 Electrical actuation**

| Marking   | Description                    |
|-----------|--------------------------------|
| <b>EI</b> | Electro-hydraulic              |
| <b>EA</b> | Combined with manual operation |

**Table 2 CAN actuation add-on**

At least one connector (marking CAN-C or CAN-T) required on the first or last valve section.  
When using a connector on the valve battery, an end plate (CAN-E) is required on the opposite valve section.

| Marking       | Description   |
|---------------|---|
| <b>CAN</b>    | CAN actuation head (all valve sections)   |
| <b>CAN-C</b>  | CAN actuation head with connection base (on the first and/or last valve section)  |
| <b>CAN-T</b>  | CAN actuation head with connection base and integrated 120 Ω terminal resistor (on the first and/or last valve section)                                       |
| <b>CAN-E</b>  | CAN actuation head with end plate   |
| <b>CAN-CC</b> | CAN actuation head with connection bases on the left and right-hand side (only possible with individual CAN actuation head)                                   |
| <b>CAN-TT</b> | CAN actuation head with connection bases and integrated terminal resistors on the left and right-hand side (only possible with individual CAN actuation head) |

For valve batteries with just one valve section with directly mounted CAN controls and a connector, the position of the connector must be defined.

L = left, connector in the direction of the connection block  
R = right, connector in the direction of the end plate

**Table 3 Connectors**

| Marking | Description                              | Appropriate connector |
|---------|--|-----------------------|
| AMP     | 4-pin connector, with protective circuit | TE 282192-1           |
| AMS     | 4-pin connector, with protective circuit | TE 1-967059-1         |
| DT      | 4-pin connector, with protective circuit | TE DEUTSCH DT06-4S    |

For examples of combination options for different connection bases, see [Chapter 2.1.1, "Combination options"](#)

**Table 4 CAN protocol**

| Marking        | Description   |
|----------------|---|
| - PLVC         | Tailored to communication with programmable logic valve control type PLVC |
| - CANopen      | CiA CANopen protocol family DS-301, DS-401, DS-408                        |
| - J1939        | SEA J 1939  |
| - 0            | Default parameter record  |
| - 1            | Customer-specific parameter record  |
| /125           | Baud rate   |
| /250 (default) | Specification in kBaud  |
| /500           |   |
| /1000          |   |

## 2.1.1 Combination options

### Combination options (examples)

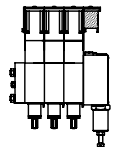
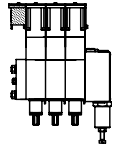
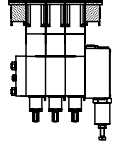
| Description               | Description   | View  |
|---------------------------|---|---|
| CAN-C - CAN - ... - CAN-E | Connection base on first valve section                        |  |
| CAN-T - CAN - ... - CAN-E | Connection base with terminal resistor on first valve section |   |
| CAN-E - CAN - ... - CAN-C | Connection base on last valve section                         |  |
| CAN-C - CAN - ... - CAN-C | Connection base on first and last valve section               |  |

## 3 Parameters

### 3.1 General parameters

#### General information

|                       |   |
|-----------------------|---|
| Material              | Actuation add-on EI CAN. nickel-plated  |
| Installation position | As desired  |
| Connection            | According to type coding, see <a href="#">D 7700-2</a> , <a href="#">D 7700-3</a> , <a href="#">D 7700-5</a> , <a href="#">D 7700-F</a> |
| Ambient temperature   | Approx. -40 to +80°C  |
| Weight                | <b>Actuation add-on EICAN</b><br>▪ + 0.3 kg   |

### 3.2 Electrical parameters

|                           |   |
|---------------------------|---|
| Operating voltage $U_B$   | 12 to 30 V DC   |
| Max. operating current    | 10 A (CAN connection base)  |
| Current consumption $I_V$ | Max. 800 mA at $U_B = 24$ V DC (per valve section)<br>Max. 1.5 A at $U_B = 12$ V DC (per valve section) |

### 3.3 Acceptance tests and environmental tests

|                        |  |
|------------------------|--|
| EMC                    | E1-ECE regulation no. 10 revision 3 - 11 July 2008   |
| Protection class IP 67 | DIN 40050-9  |
| Shocks                 | EN 60068-2-29      25 g, 3 axes  |
| Vibrations             | EN 60068-2-6      5 to 500 Hz, 2 mm amplitude<br>(5 to 25 Hz), 5.0 g (25 to 500 Hz),<br>3 axes |
| Temperature change     | EN 60068-2-14      -40°C to +85°C (1.5 K/min)  |
| Coldness               | EN 60068-2-1      -40°C  |
| Damp heat              | EN 60068-2-30      95% air humidity, 24 h  |
| Dry heat               | EN 60068-2-2      85°C, 16 h   |

### 3.4 Electrical connection

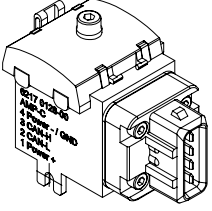
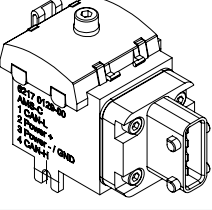
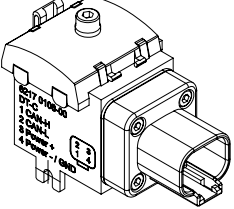
| Marking | Description                                | Terminal assignment                                   |  |
|---------|--|---|--|
| AMP     | 4-pin<br>Connector with protective circuit | 1: Power +<br>2: CAN-L<br>3: CAN-H<br>4: Power - /GND |   |
| AMS     | 4-pin<br>Connector with protective circuit | 1: CAN-L<br>2: Power +<br>3: Power - /GND<br>4: CAN-H |   |
| DT      | 4-pin<br>Connector with protective circuit | 1: CAN-H<br>2: CAN-L<br>3: Power +<br>4: Power - /GND |  |

AMP

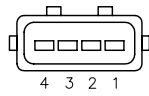

AMS

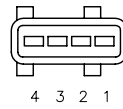

DT





## 4 Dimensions

All dimensions in mm, subject to change!

### 4.1 Actuation add-on

Actuation add-on **CAN-C**, **CAN-T** and **CAN**

Size 2  
(series connection)

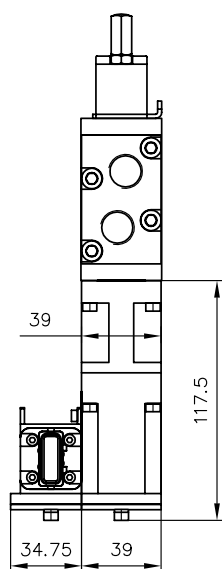

Size 3  
(series connection)

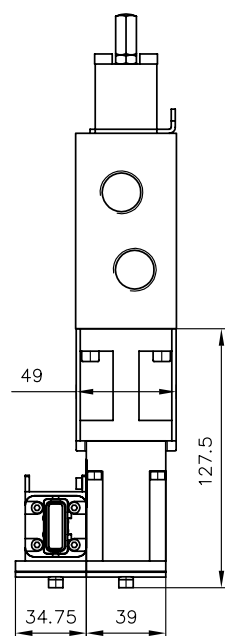

Size 5  
(series connection)

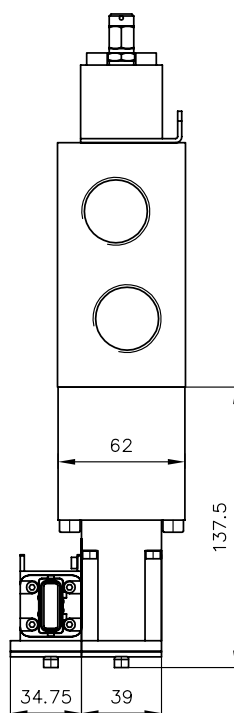

Size 3  
(manifold mounting)

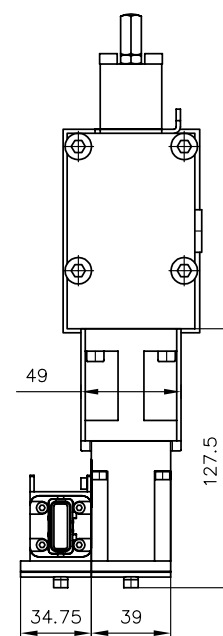

## 4.2 Structure of valve bank (series connection) – example

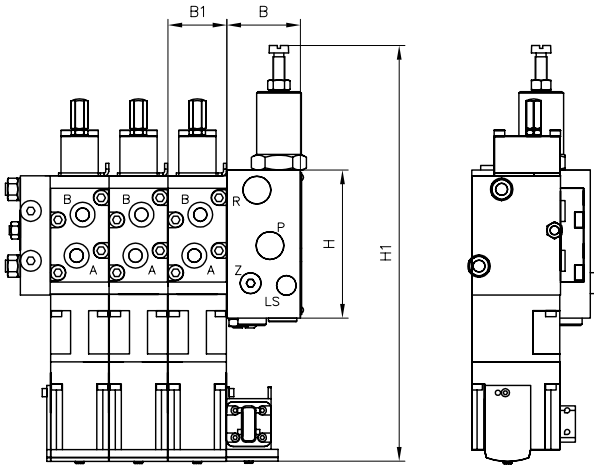
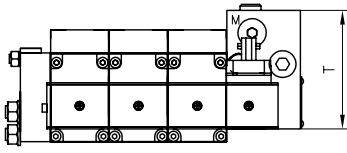

| Marking        | B    | B1   | H          | H1    | T    |
|----------------|------|------|------------|-------|------|
| PSL/PSV size 2 | 49.5 | 39.5 | 99.5       | 279   | 79.5 |
| PSL/PSV size 3 | 49.8 | 49.5 | 110 to 123 | 294   | 80   |
| PSL/PSV size 5 | 99.5 | 62.5 | 137.5      | 314.5 | 100  |

### 4.3 Structure of valve bank (manifold mounting) – example

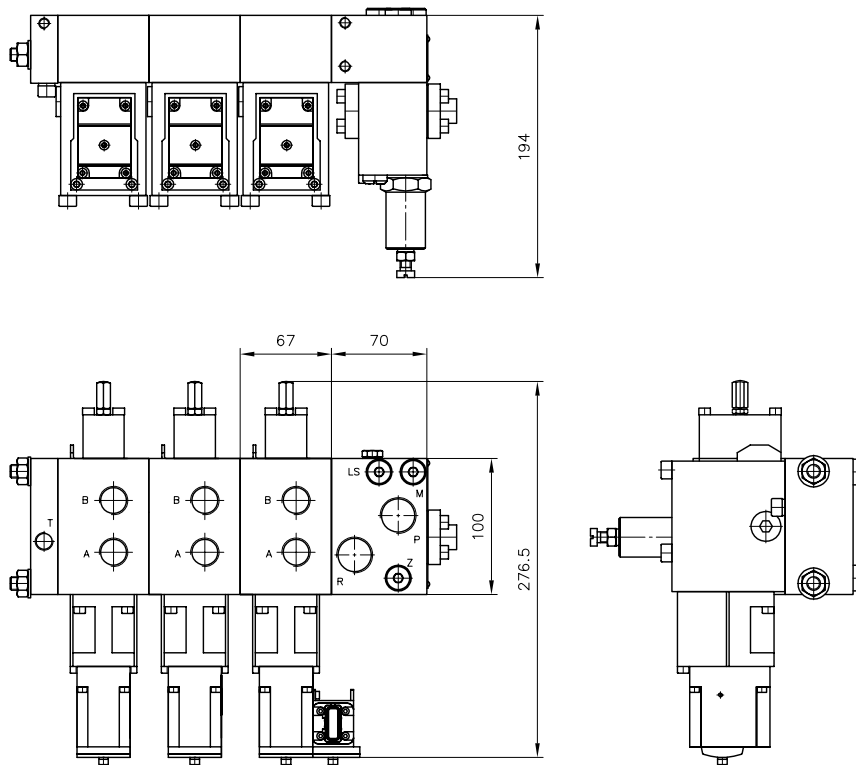

### 5.1 Designated use

This fluid-power product has been designed, manufactured and tested using standards and regulations generally applicable in the European Union and left the plant in a safe and fault-free condition.

To maintain this condition and ensure safe operation, operators must observe the information and warnings in this documentation.

This fluid-power product must be installed and integrated in a hydraulic system by a qualified specialist who is familiar with and adheres to general engineering principles and relevant applicable regulations and standards.

In addition, application-specific features of the system or installation location must be taken into account if relevant.

This product may only be used within oil-hydraulic systems.

The product must be operated within the specified technical parameters. This documentation contains the technical parameters for various product versions.

**Note**

Non-compliance will void any warranty claims made against HAWE Hydraulik.

### 5.2 Operating instructions

#### Product, pressure and/or flow settings

All statements in this documentation must be observed for all product, pressure and/or flow settings on or in the hydraulic system.

**Caution**

**Risk of injury on overloading components due to incorrect pressure settings!**

- Always monitor the pressure gauge when setting or changing the pressure.

#### Filtering and purity of the hydraulic fluid

Soiling in the fine range, e.g. abraded material and dust, or in the macro range, e.g. chips, rubber particles from hoses and seals, can cause significant malfunctions in a hydraulic system. It is also to be noted that new hydraulic fluid “from the drum” does not necessarily meet the highest purity requirements.

Pay attention to the purity of the hydraulic fluid in order to maintain faultless operation.

### 5.3 Maintenance information

This product is largely maintenance-free.

Conduct a visual inspection to check the hydraulic connections for damage at regular intervals, but at least once per year. If external leaks are found, shut down and remedy.

Check the device surfaces for dust deposits at regular intervals (but at least annually) and clean the device if required.

### 5.4 Safety instructions

All installation, set-up, maintenance and repairs must be performed by authorised, qualified and trained staff. The use of this product beyond the specified performance limits, operation with non-specified fluids and/or use of non-genuine spare parts will invalidate the warranty.

The general operating manual for the assembly, commissioning and maintenance of oil-hydraulic components and systems must be observed.

### Transportation and storage

Analogous to hydraulic components, proper storage and suitable packaging for the product must be ensured. There are no particular requirements resulting from the combination of control electronics and valve.

**Note**

The plastic connector base is mechanically limited in terms of load capacity and is unsuitable for use as a handle!

## 5.5 Assembly and installation instructions

### Mounting

The valve bank must be mounted free from distortion to the machine chassis or frame. It is recommended to mount using three screws and to use elastic spacers between the block and the frame.

### Installation

To ensure safe operation of the PSL/PSV CAN valve nodes and to avoid shortening the lifetime of the product through improper operating conditions, the following instructions must be observed:

- Avoid installing the valves near machine parts and assemblies that produce lots of heat (e.g. exhaust).
- Radio equipment must be a sufficient distance away.
- An emergency shut-off must be provided for the power supply. The emergency stop switch must be installed on the machine (vehicle) where it is easily accessible by the machine/system operator. The machine (vehicle) manufacturer must ensure that a safe state is produced when the emergency stop switch is actuated.
- One of the mechanisms supported by the device to protect against bus interruptions (node guarding, heartbeat) must be used.
- The power feed must be dimensioned and fused in accordance with the maximum possible current consumption. A maximum current of approx. 1.5 A at 12 V and 0.8 A at 24 V supply must be set per valve section.
- Earth lines must be dimensioned in accordance with the maximum currents flowing to them. The reference potential for all CAN bus nodes connected to a single line should vary as little as possible from device to device and be identical with the earth connection for the power supply.
- All valve nodes must be unplugged in the event of electric welding work.
- Connectors used to connect the valve battery must be properly secured against water ingress by applying all necessary seals.
- Bus lines suitable for CAN bus networks must be used. Lines should ideally be twisted and screened. The surge impedance must be approx. 120  $\Omega$ .
- There must be 120  $\Omega$  terminating resistors at both ends of the CAN bus network.
- Valve electronics and the associated magnet block are screwed together and sealed. They must not be separated from each other. When replacing the valve spool or the spool block, ensure correct reassembly and sealing.
- Maintain a sufficient distance from sources of magnetic fields, e.g. strong permanent magnets, eddy-current brakes etc. (> 0.5 m).
- If the bus and supply line needs to be removed from individual valve modules during installation or servicing, new cables must be used for reassembly and the sealing elements and end caps must be correctly installed. Cables are available as spare parts.

The following must also be observed during operation:

- The proper operation of the control unit can be ensured only within a temperature range of -40°C to +85°C.
- If the device detects internal overheating, restricted operation (i.e. at reduced power) is possible within a certain temperature range.
- Increased surface temperature and burning on contact can particularly occur at the magnet block.
- The power supply must be within the specified working range. High or constant deviation can damage the electronics.

## 5.6 CAN bus control unit

### General information

The CAN bus (Controller Area Network) is an asynchronous, serial bus system requiring just two wires for data transmission. According to ISO 11898-2 (High-Speed Medium Access Unit), twisted-pair cables with a surge impedance of 108 to 132  $\Omega$  are recommended as a bus medium.

Conventional data transmission formats are protocols CANopen 2.0 A & B and J1939, based on 11 Bit or 29 Bit address data.

### Design of CAN bus systems

In general, a linear network topology should be aimed for and spur lines should be avoided. If this is not possible, the maximum spur line lengths in accordance with Table 1 apply.

Short bus lines with a low EMC load do not require the CAN line to be screened. For major network expansion or environments with EMC loads, screening of the CAN line with corresponding earthing should be applied. Twisted bus cables are a compromise solution that are easier to implement in cable harnesses. There must not be a shift in potential between the individual CAN nodes. Device earths for all CAN node devices must be sufficiently dimensioned and should be brought together at a common neutral point. If a CAN PSL/PSV valve bank is operated in the passage, i.e. it has two contact bases and is looped into the bus line, the maximum current carrying capacity of the contact bases must be observed. If necessary, bus nodes with a high current consumption should not be supplied via the valve battery, but have their own power supply. A max. current of 10 A must not be exceeded.

| Transfer rate | Bus length | Max. length of spur line |
|---------------|------------|--------------------------|
| 100 kbit/s    | 600 m      | 25 m                     |
| 125 kbit/s    | 500 m      | 20 m                     |
| 250 kbit/s    | 250 m      | 10 m                     |
| 500 kbit/s    | 100 m      | 5 m                      |
| 1,000 kbit/s  | < 20 m     | 1 m                      |

The power supply and the CAN bus are passed from section to section by means of an internal cable connection. The connection cable contains four wires: power supply (uBat, GND) and CAN bus (CAN high, CAN low). The recommended terminating resistor is not necessary for short spur lines.

### Plug-and-Play slave valve nodes with PLVC

A Plug-and-Play configuration can be used for CAN nodes to provide an extended output level with the HAWE control units of type PLVC. Requiring no communication within the user program, these external valve outputs are managed by the PLVC operating system and can be used in a way analogous to existing valve outputs.

Plug-and-Play functionality requires merely the following requirements for the address specification: The external valves controlled via CAN bus must be assigned to CAN node IDs from 32 onwards; all other data traffic and the associated monitoring and safety functions are assumed by the PLVC.

Single valves are addressed with sequential indices from 2000 onwards. The indices of twin valves are calculated based on  $2000 + 2 \cdot n$ , where  $n$  is the number of sections.

| Section number $n$ | PLVC ID | Node ID | Target COB ID | Actual COB ID |
|--------------------|---------|---------|---------------|---------------|
| 1                  | 2000    | 32      | 0x220         | 0x1A0         |
| 2                  | 2002    | 34      | 0x222         | 0x1A2         |
| 3                  | 2004    | 36      | 0x224         | 0x1A4         |
| 4                  | 2006    | 38      | 0x226         | 0x1A6         |
| 5                  | 2008    | 40      | 0x228         | 0x1A8         |
| 6                  | 2010    | 42      | 0x22A         | 0x1AA         |
| 7                  | 2012    | 44      | 0x22C         | 0x1AC         |
| 8                  | 2014    | 46      | 0x22E         | 0x1AE         |
| 9                  | 2016    | 48      | 0x230         | 0x1B0         |
| 10                 | 2018    | 50      | 0x232         | 0x1B2         |



## 5.7 Structure of the CAN actuation head

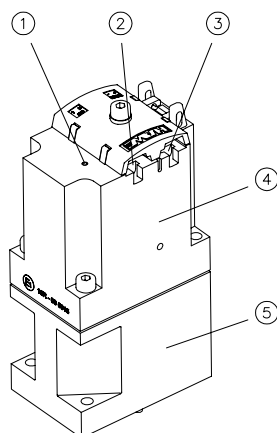

|   |                          |
|---|--------------------------|
| 1 | Status LED               |
| 2 | Data line (CAN-L, CAN-H) |
| 3 | Power supply (+/-)       |
| 4 | Electronics module       |
| 5 | Actuation unit           |

## 5.8 CAN starter set

The CAN starter set enables communication and functionality of CAN valves from a desk, i.e. without a fully functioning complete hydraulic system.

With the CAN starter set, a PC can be used as a partner for the valve (point-to-point connection to the CAN dongle). However, complete bus system simulations containing several bus nodes can also be run.

### Scope of delivery

- Electronics module including actuating solenoid
- 4-pin AMP mating connector for adaptation to D-Sub and 4-mm spring connector for power supply
- Data carrier with the HAWES CanNodeTool and drivers

Order coding and item numbers:

- PSX-CAN starter kit: 3405 4200-00
- PEAK CAN USB dongle: 6219 2001-00

A power supply unit for the electric power supply is not included in the scope of delivery. This is required for operation (e.g. 24 V, 1 A).

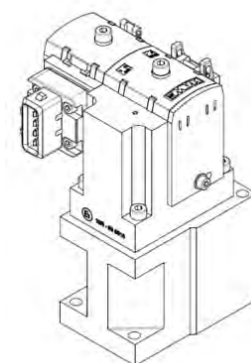

## Additional versions

- Proportional directional spool valve, type PSL and PSV size 2: D 7700-2
- Proportional directional spool valve, type PSL, PSM and PSV size 3: D 7700-3
- Proportional directional spool valve, type PSL, PSM and PSV size 5: D 7700-5
- Proportional directional spool valve type PSLF, PSVF and SLF size 3: D 7700-3F
- Programmable logic valve control type PLVC 8: D 7845 M
- CAN node type CAN-IO: D 7845-IO 14