

Hydraulic power packs type MPN and MPNW

for the short time, on/off- and intermittent operation



Operating pressure p_{max} = 700 bar (radial piston pump)
 Flow Q_{max} = 139 lpm (gear pump)

For additional information see:

Hydraulic power packs	type MP	D 7200 ++
	type HK	D 7600 ++
Connection blocks	type A	D 6905 A/1, D 6905 TÜV
	type B	D 6905 B
	type C	D 6905 C, Sk 6906 C
Directly mountable valve banks		
Valve banks	type BA	D 7788
Directional seated valves	type VB	D 7302
Directional seated valves	type BWN, BWH	D 7470 B/1
Directional seated valves	type BVZP	D 7785 B
Two stage valves	type NE	D 7161
Pressing tax valves	type CR	D 7150

1. Design and general information

The compact hydraulic power pack serves to supply pressurized fluid for intermittently or short-term operated hydraulic circuits.

The basic hydraulic power pack consists:

- Tank (available in different sizes)
- Drive motor (available for different voltages and power requirements)
- Radial piston and/or gear pump directly driven by the motor shaft

The compact style obtained with this design represents an essential advantage opposite conventional units. Complete turn-key solutions can be easily arranged via a wide range of connection blocks (see D 6905 ++) and directly mountable valve banks.

There is a wide field of applications for these compact power packs within tool machines, jig assemblies and general mechanical engineering.

Versions

- Single circuit pumps (radial piston or gear pump)
- Dual circuit pumps
 - High pressure - High pressure (H-H)
 - High pressure - Low pressure (H-Z)
- Tank or cover plate version

Electrical connection

- 3~ or 1~phase

Operating mode

The pumps are rated for use in short time and on/off service S2 and S3.

Intermittent service S6 is possible as long as the tank has a sufficient size (dep. pump size and load).

Symbols

Single circuit

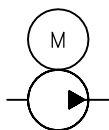

Dual circuit

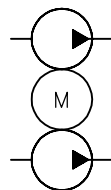

Order example

MPN 42 - HZ 0,83/21 - B25.20 KT
 - AN 23 F 3 - D 45 - B 500
 - 3x400/230V 50 Hz

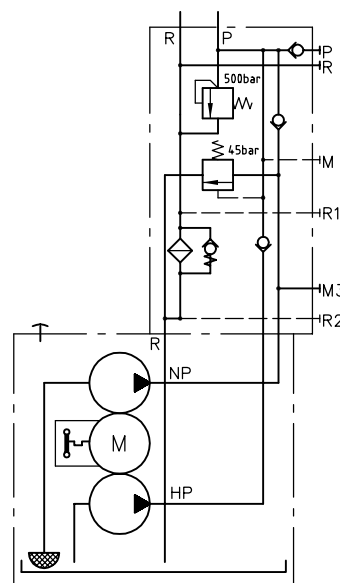

2. Available versions, type coding

Order examples:

MPN 404 - H 13,1 - 3x400/230 V 50 Hz Motor/pump-combination only

MPN 48 - HZ 8,6/21 - B110.90 - KT R 4 - CR 4 M - G 24- 270/60 - 3x400/230 V 50 Hz

Dual circuit hydraulic power pack, version with tank and switch-off valve type CR 4 M

MPN 44 - H 3,2 - B10.20 - DKT R 3 P - B 31/300-EM11V-13/5E4-G24 - 3x400/230 V 50 Hz

Hydraulic power pack (incl. tank)

see table 2

For connection blocks and directly mountable valves, see sect. 4.5

Motor voltage

Table 6: Electrical connection

Coding	Note
-	Standard (terminal box)
P	Plug Co. Harting

Table 5: Additional ports

Additional port	Coding and ports conf. ISO 228/1 (BSPP)		
	R		
Additional return port	G 1/2	G 3/4	G 1
For tank and cover plate version	D10. B10.	D25. B25.	D55. B55. B110.

Table 4: Options

Coding	Note
no coding	no options
K	Oil level gauge
S	Float switch (NO-contact)
D	Float switch (NC-contact)
T	Temperature switch (standard at type MPNWX)

Table 3: Tank or cover plate with coding for connection pedestal

For motor, pump and tank coding, see sect. 2.3

For connection base, see sect. 2.3 and 4.4.

Coding 90 suited for type CR 4 M (acc. to D 7150) and type NE 70 (acc. to D 7161)

Tank design	Cover plate design	Filling volume $V_{filling}$ (l)	Usable filling volume V_{usable} (l)	Connection pedestal Codings Q (lpm)
B10. ..	D10. ..	17	10	20
B25. ..	D25. ..	37	30	20, 80, 90
B55. ..	D55. ..	75	55	20, 80, 90, 160
B110. ..	D55. ..	100	75	20, 80, 90, 160

Table 1: Basic type and power rating

Coding	Nominal power (kW)	Nominal speed at 50 Hz (rpm)	Power supply
MPN 42	2.1	2785	3~phase mains
MPN 44	2.1	1360	
MPN 46	3.0	2815	
MPN 48	3.0	1370	
MPN 404	4.2	1380	
MPNWX 42	1.5	2800	1~phase mains
MPNWX 44	1.5	1375	

Table 2: Pump and flow coding

Coding	Note
H...	Radial piston pump
Z...	Gear pump
IZ...	Internal gear pump
HH.../...	Dual circuit pump, 2 x radial piston pump
HZ.../...	Dual circuit pump, radial piston- / gear pump

Flow coding

see page 3, sect. 2.1

2.1 Single circuit pumps

2.1.1 High pressure pumps

Order example: MPN 48 - H 3,8 - B25.20 DT- 3x400/230 V 50 Hz

Table 7: Radial piston pump version with 3~phase motor

Basic type	Parameters	Delivery flow coding, geom. displacement, perm. pressure, delivery flow								
		Piston diameter (mm)								
		6	7	6	8	7	8	10	6	12
	Delivery flow coding	0,6	0,83	0,9	1,0	1,25	1,5	1,6	1,8	2,4
	Geom. displacement V_g (cm ³ /rev.)	0.43	0.58	0.64	0.76	0.88	1.15	1.19	1.29	1.72
	Number of pump elements	2	2	3	2	3	3	2	6	2
MPN 42	Pressure p_{max} (bar)	700	700	700	700	700	590	560	525	390
	Delivery flow 50 Hz	1.17	1.60	1.76	2.09	2.39	3.13	3.26	3.52	4.69
	Q_{Pu} (lpm) 60 Hz	1.41	1.92	2.11	2.50	2.87	3.75	3.91	4.22	5.63
MPN 44	Pressure p_{max} (bar)	700	700	700	700	700	700	600	700	420
	Delivery flow 50 Hz	0.57	0.78	0.86	1.02	1.17	1.53	1.59	1.72	2.29
	Q_{Pu} (lpm) 60 Hz	0.69	0.94	1.03	1.22	1.40	1.83	1.91	2.06	2.75
MPN 46	Pressure p_{max} (bar)	700	700	700	700	700	700	600	700	420
	Delivery flow 50 Hz	1.19	1.61	1.78	2.11	2.42	3.16	3.29	3.56	4.74
	Q_{Pu} (lpm) 60 Hz	1.42	1.94	2.13	2.53	2.90	3.79	3.95	4.27	5.69
MPN 48	Pressure p_{max} (bar)	700	700	700	700	700	700	600	700	420
	Delivery flow 50 Hz	0.58	0.79	0.87	1.03	1.18	1.54	1.60	1.73	2.31
	Q_{Pu} (lpm) 60 Hz	0.69	0.94	1.04	1.23	1.41	1.85	1.92	2.08	2.77
MPN 404	Pressure p_{max} (bar)	700	700	700	700	700	700	600	700	420
	Delivery flow 50 Hz	0.58	0.79	0.87	1.03	1.19	1.55	1.61	1.74	2.32
	Q_{Pu} (lpm) 60 Hz	0.70	0.95	1.05	1.24	1.42	1.86	1.94	2.09	2.79

Basic type	Parameters	Delivery flow coding, geom. displacement, perm. pressure, delivery flow								
		Piston diameter (mm)								
		7	10	13	8	14	12	15	13	16
	Delivery flow coding	2,45	2,5	2,8	3,2	3,3	3,6	3,8	4,3	4,4
	Geom. displacement V_g (cm ³ /rev.)	1.75	1.79	2.02	2.29	2.34	2.58	2.69	3.03	3.06
	Number of pump elements	6	3	2	6	2	3	2	3	2
MPN 42	Pressure p_{max} (bar)	385	380	330	295	290	260	250	220	220
	Delivery flow 50 Hz	4.79	4.89	5.51	6.26	6.39	7.04	7.33	8.26	8.34
	Q_{Pu} (lpm) 60 Hz	2.81	5.86	6.61	3.67	7.66	8.45	8.80	9.91	10.01
MPN 44	Pressure p_{max} (bar)	650	600	360	500	310	420	270	360	240
	Delivery flow 50 Hz	2.34	2.39	2.69	3.05	3.12	3.44	3.58	4.03	4.07
	Q_{Pu} (lpm) 60 Hz	2.81	2.86	3.23	3.67	3.74	4.12	4.30	4.84	4.89
MPN 46	Pressure p_{max} (bar)	590	580	360	450	310	400	270	340	240
	Delivery flow 50 Hz	4.84	4.94	5.57	6.32	6.45	7.11	7.41	8.35	8.43
	Q_{Pu} (lpm) 60 Hz	5.81	5.93	6.68	7.59	7.75	8.54	8.89	10.02	10.12
MPN 48	Pressure p_{max} (bar)	700	600	360	700	310	420	270	360	240
	Delivery flow 50 Hz	2.36	2.40	2.71	3.08	3.14	3.46	3.61	4.06	4.10
	Q_{Pu} (lpm) 60 Hz	2.83	2.89	3.25	3.69	3.77	4.15	4.33	4.88	4.92
MPN 404	Pressure p_{max} (bar)	700	600	360	700	310	420	270	360	240
	Delivery flow 50 Hz	2.37	2.42	2.73	3.10	3.16	3.49	3.63	4.09	4.13
	Q_{Pu} (lpm) 60 Hz	2.85	2.91	3.27	3.72	3.80	4.18	4.36	4.19	4.96

Continuation of table 7: Radial piston pump version with 3~phase motor

Basic type	Parameters	Delivery flow coding, geom. displacement, perm. pressure, delivery flow								
		Piston diameter (mm)								
		10	14	15	16	12	13	14	15	16
	Delivery flow coding	5,0	5,1	5,6	6,5	7,2	8,6	9,9	11,5	13,1
	Geom. displacement V_g (cm ³ /rev.)	3.58	3.51	4.03	4.58	5.16	6.05	7.02	8.06	9.17
	Number of pump elements	6	3	3	3	6	6	6	6	6
MPN 42	Pressure p_{max} (bar)	190	190	165	145	130	110	95	80	70
	Delivery flow 50 Hz	9.77	9.58	11.00	12.51	14.08	16.52	19.16	21.99	25.02
	Q_{Pu} (lpm) 60 Hz	5.73	11.50	13.20	15.01	8.25	9.68	11.23	12.89	14.66
MPN 44	Pressure p_{max} (bar)	320	310	270	240	220	190	165	140	120
	Delivery flow 50 Hz	4.77	4.68	5.37	6.11	6.87	8.07	9.36	10.74	12.22
	Q_{Pu} (lpm) 60 Hz	5.73	5.61	6.44	7.33	8.25	9.68	11.23	12.89	14.66
MPN 46	Pressure p_{max} (bar)	290	290	250	225	200	170	145	125	110
	Delivery flow 50 Hz	9.88	9.68	11.12	12.65	14.23	16.70	19.36	22.23	25.29
	Q_{Pu} (lpm) 60 Hz	11.86	11.62	13.34	15.18	17.07	20.04	23.24	26.68	30.35
MPN 48	Pressure p_{max} (bar)	480	310	270	240	335	285	245	215	185
	Delivery flow 50 Hz	4.81	4.71	5.41	6.15	6.92	8.13	9.42	10.82	12.31
	Q_{Pu} (lpm) 60 Hz	5.77	5.65	6.49	7.39	8.31	9.75	11.31	12.98	14.77
MPN 404	Pressure p_{max} (bar)	560	310	270	240	420	360	310	270	240
	Delivery flow 50 Hz	4.84	4.75	5.45	6.20	6.97	8.19	9.49	10.90	12.40
	Q_{Pu} (lpm) 60 Hz	5.81	5.70	6.54	7.44	8.37	9.82	11.39	13.08	14.88

Tabelle 8: Radialkolbenpumpenausführung mit Wechselstrommotor

Basic type	Parameters	Delivery flow coding, geom. displacement, perm. pressure, delivery flow								
		Piston diameter (mm)								
		6	7	6	8	7	8	10	6	12
	Delivery flow coding	0,6	0,83	0,9	1,0	1,25	1,5	1,6	1,8	2,4
	Geom. displacement V_g (cm ³ /rev.)	0.43	0.58	0.64	0.76	0.88	1.15	1.19	1.29	1.72
	Number of pump elements	2	2	3	2	3	3	2	6	2
MPNW 42	Pressure p_{max} (bar)	700	670	610	515	445	340	330	305	225
	¹⁾ Delivery flow Q_{Pu} (lpm) 50 Hz	1.18	1.61	1.77	2.10	2.41	3.14	3.28	3.54	4.72
MPNW 44	Pressure p_{max} (bar)	700	700	700	700	700	700	700	700	490
	¹⁾ Delivery flow Q_{Pu} (lpm) 50 Hz	0.58	0.79	0.87	1.03	1.18	1.54	1.61	1.74	2.32

Basic type	Parameters	Delivery flow coding, geom. displacement, perm. pressure, delivery flow								
		Piston diameter (mm)								
		7	10	13	8	14	12	15	13	16
	Delivery flow coding	2,45	2,5	2,8	3,2	3,3	3,6	3,8	4,3	4,4
	Geom. displacement V_g (cm ³ /rev.)	1.75	1.79	2.02	2.29	2.34	2.58	2.69	3.03	3.06
	Number of pump elements	6	3	2	6	2	3	2	3	2
MPNW 42	Pressure p_{max} (bar)	225	220	195	170	165	150	145	130	125
	¹⁾ Delivery flow Q_{Pu} (lpm) 50 Hz	4.82	4.91	5.54	6.29	6.42	7.08	7.37	8.30	8.39
MPNW 44	Pressure p_{max} (bar)	550	545	415	425	360	330	315	320	275
	¹⁾ Delivery flow Q_{Pu} (lpm) 50 Hz	2.36	2.41	2.72	3.09	3.15	3.47	3.62	4.08	4.12

¹⁾ **Note:** The 1~phase version will not start-up while pressurized (see sect. 3.2)

Continuation of table 8: Radial piston pump version with 1~phase motor

Basic type	Parameters	Delivery flow coding, geom. displacement, perm. pressure, delivery flow								
		Piston diameter (mm)								
		10	14	15	16	12	13	14	15	16
	Delivery flow coding	5,0	5,1	5,6	6,5	7,2	8,6	9,9	11,5	13,1
	Geom. displacement V_g (cm ³ /rev.)	3.58	3.51	4.03	4.58	5.16	6.05	7.02	8.06	9.17
	Number of pump elements	6	3	3	3	6	6	6	6	6
MPNW 42	Pressure p_{max} (bar)	110	110	95	85	75	65	55	45	40
	1) Delivery flow Q_{Pu} (lpm) 50 Hz	9.83	9.63	11.06	12.85	14.15	16.61	19.26	22.11	25.16
MPNW 44	Pressure p_{max} (bar)	270	280	240	210	190	160	140	120	100
	1) Delivery flow Q_{Pu} (lpm) 50 Hz	4.83	4.73	5.43	6.18	6.95	8.16	9.46	10.86	12.35

1) **Note:** The 1~phase version will not start-up while pressurized (see sect. 3.2)

2.1.2 Gear pumps

Order example: MPN 48 - **Z 9** - B 55.20 - A 51/320 - 3x400/230 V 50 Hz

Table 9: Gear pump version with 3~phase motor

Basic type	Parameters Size 1	Delivery flow coding, geom. displacement, perm. pressure, delivery flow									
		Z 2,0	Z 2,7	Z 3,5	Z 4,5	Z 5,2	Z 6,9	Z 8,8	Z 9,8	Z 11,3	Z 14,4
	Delivery flow coding										
	Geom. displacement V_g (cm ³ /rev.)	1.50	2.00	2.50	3.10	4.00	4.90	6.20	6.50	7.90	9.90
MPN 42	Pressure p_{max} (bar)	200	200	200	200	170	135	110	105	85	65
	Delivery flow 50 Hz	4.09	5.46	6.82	8.46	10.92	13.37	16.92	17.74	21.56	27.02
	Q_{Pu} (lpm) 60 Hz	4.91	6.55	8.19	10.15	13.10	16.05	20.31	21.29	25.87	32.42
MPN 44	Pressure p_{max} (bar)	200	200	200	200	200	200	185	175	145	115
	Delivery flow 50 Hz	2.00	2.67	3.33	4.13	5.33	6.53	8.26	8.66	10.53	13.19
	Q_{Pu} (lpm) 60 Hz	2.40	3.20	4.00	4.96	6.40	7.84	9.92	10.40	12.63	15.83
MPN 46	Pressure p_{max} (bar)	200	200	200	200	200	200	165	160	130	105
	Delivery flow 50 Hz	4.14	5.52	6.90	8.55	11.03	13.52	17.10	17.93	21.79	27.31
	Q_{Pu} (lpm) 60 Hz	4.97	6.62	8.28	10.26	13.24	16.22	20.52	21.52	26.15	32.77
MPN 48	Pressure p_{max} (bar)	220	220	220	220	200	200	200	200	200	170
	Delivery flow 50 Hz	2.01	2.69	3.36	4.16	5.37	6.58	8.32	8.73	10.61	13.29
	Q_{Pu} (lpm) 60 Hz	2.42	3.22	4.03	4.99	6.44	7.89	9.99	10.47	12.73	15.90
MPN 404	Pressure p_{max} (bar)	220	220	200	200	200	200	200	200	200	200
	Delivery flow 50 Hz	2.03	2.70	3.38	4.19	5.41	6.63	8.38	8.79	10.68	13.39
	Q_{Pu} (lpm) 60 Hz	2.43	3.25	4.06	5.03	6.49	7.95	10.06	10.55	12.82	16.07

Continuation of table 9: Gear pump version with 3~phase motor

Basic type	Parameters Size 2		Delivery flow coding, geom. displacement, perm. pressure, delivery flow							
	Delivery flow coding		Z 6,5	Z 9,0	Z 12,3	Z 16	Z 21	Z 24	Z 28	Z 37
	Geom. displacement V_g	(cm ³ /rev.)	4.50	6.00	8.50	11.00	14.50	17.00	19.50	26.00
MPN 42	Pressure p_{max}	(bar)	150	110	80	60	45	40	35	25
	Delivery flow	50 Hz	12.28	16.38	23.20	30.02	39.57	46.40	53.22	70.96
	Q_{Pu} (lpm)	60 Hz	14.74	19.65	27.84	36.03	47.49	55.68	63.87	85.15
MPN 44	Pressure p_{max}	(bar)	200	190	135	100	80	65	55	40
	Delivery flow	50 Hz	6.00	8.00	11.33	14.66	19.33	22.66	25.99	34.65
	Q_{Pu} (lpm)	60 Hz	7.20	9.60	13.59	17.59	23.19	27.19	31.19	41.58
MPN 46	Pressure p_{max}	(bar)	200	170	120	95	70	60	50	40
	Delivery flow	50 Hz	12.41	16.55	23.45	30.35	40.00	46.90	53.79	71.73
	Q_{Pu} (lpm)	60 Hz	14.90	19.86	28.14	36.41	48.00	56.28	64.55	86.07
MPN 48	Pressure p_{max}	(bar)	210	210	195	150	115	95	85	60
	Delivery flow	50 Hz	6.04	8.06	11.41	14.77	19.47	22.82	26.18	34.91
	Q_{Pu} (lpm)	60 Hz	7.25	9.67	13.69	17.72	23.36	27.39	31.42	41.89
MPN 404	Pressure p_{max}	(bar)	210	210	210	205	180	150	130	100
	Delivery flow	50 Hz	6.09	8.11	11.50	14.88	19.61	22.99	26.37	35.16
	Q_{Pu} (lpm)	60 Hz	7.30	9.74	13.79	17.85	23.53	27.59	31.65	42.19

Basic type	Parameters Size 3		Delivery flow coding, geom. displacement, perm. pressure, delivery flow			
	Delivery flow coding		Z 45	Z 59	Z 75	Z 87
	Geom. displacement V_g	(cm ³ /rev.)	30.20	41.80	50.40	61.00
MPN 44	Pressure p_{max}	(bar)	35	25	-	-
	Delivery flow	50 Hz	40.25	55.71	-	-
	Q_{Pu} (lpm)	60 Hz	48.30	66.85	-	-
MPN 46	Pressure p_{max}	(bar)	30	25	20	-
	Delivery flow	50 Hz	83.31	115.31	139.04	-
	Q_{Pu} (lpm)	60 Hz	99.98	138.38	166.85	-
MPN 48	Pressure p_{max}	(bar)	50	40	30	25
	Delivery flow	50 Hz	40.55	56.12	67.67	81.90
	Q_{Pu} (lpm)	60 Hz	48.66	67.34	81.20	98.28
MPN 404	Pressure p_{max}	(bar)	80	60	50	40
	Delivery flow	50 Hz	40.84	56.53	68.16	82.50
	Q_{Pu} (lpm)	60 Hz	49.01	67.84	81.79	99.00

Table 10: Gear pump version with 1~phase motor

Basic type	Parameters Size 1		Delivery flow coding, geom. displacement, perm. pressure, delivery flow									
	Delivery flow coding		Z 2,0	Z 2,7	Z 3,5	Z 4,5	Z 5,2	Z 6,9	Z 8,8	Z 9,8	Z 11,3	Z 14,4
	Geom. displacement V_g	(cm ³ /rev.)	1.50	2.00	2.50	3.10	4.00	4.90	6.20	6.50	7.90	9.90
MPNW 42 1)	Pressure p_{max}	(bar)	200	195	155	125	95	80	60	60	50	40
	Delivery flow Q_{Pu} (lpm)	50 Hz	4.12	5.47	6.86	8.51	10.98	13.45	17.01	17.84	21.68	27.17
MPNW 44 1)	Pressure p_{max}	(bar)	200	200	200	200	200	190	155	150	120	95
	Delivery flow Q_{Pu} (lpm)	50 Hz	2.02	2.70	3.37	4.18	5.39	6.60	8.35	8.76	10.65	13.34

1) **Note:** The 1~phase version will not start-up while pressurized (see sect. 3.2)

Continuation of table 10: Gear pump version with 1~phase motor

Basic type	Parameters Size 2		Delivery flow coding, geom. displacement, perm. pressure, delivery flow							
	Delivery flow coding		Z 6,5	Z 9,0	Z 12,3	Z 16	Z 21	Z 24	Z 28	Z 37
	Geom. displacement V_g	(cm ³ /rev.)	4.50	6.00	8.50	11.00	14.50	17.00	19.50	26.00
MPNW 42	Pressure p_{max}	(bar)	85	65	45	35	25	20	20	15
	1) Delivery flow Q_{Pu}	(lpm) 50 Hz	12.35	16.46	23.32	30.18	39.79	46.65	53.51	71.34
MPNW 44	Pressure p_{max}	(bar)	200	160	115	85	65	55	50	35
	1) Delivery flow Q_{Pu}	(lpm) 50 Hz	6.06	8.09	11.45	14.82	19.54	22.91	26.28	35.04

1) **Note:** The 1~phase version will not start-up while pressurized (see sect. 3.2)

2.1.3 Internal gear pumps

Order example: MPN 404 - **IZ 22,9** - B 110.80 - DT R 5 - 3 x 400/230 V 50 Hz

Table 11: Internal gear wheel version with 3~phase motor

Basic type	Parameters Size 2		Delivery flow coding, geom. displacement, perm. pressure, delivery flow					
	Delivery flow coding		IZ 7,5	IZ 9,1	IZ 11,9	IZ 16,2	IZ 19,2	IZ 22,9
	Geom. displacement V_g	(cm ³ /rev.)	5.40	6.40	7.90	10.90	13.30	15.80
MPN 42	Pressure p_{max}	(bar)	115	95	80	55	45	40
	Delivery flow	50 Hz	14.74	17.47	21.56	29.75	36.30	43.12
	Q_{Pu} (lpm)	60 Hz	17.69	20.96	25.87	35.70	43.56	51.75
MPN 44	Pressure p_{max}	(bar)	200	160	130	100	80	70
	Delivery flow	50 Hz	7.20	8.53	10.53	14.53	17.73	21.06
	Q_{Pu} (lpm)	60 Hz	8.64	10.24	12.63	17.43	21.27	25.27
MPN 46	Pressure p_{max}	(bar)	180	155	125	90	70	60
	Delivery flow	50 Hz	14.90	17.66	21.79	30.07	36.69	43.59
	Q_{Pu} (lpm)	60 Hz	12.50	14.81	18.29	25.23	30.78	36.57
MPN 48	Pressure p_{max}	(bar)	250	250	215	155	125	105
	Delivery flow	50 Hz	7.25	8.59	10.61	14.63	17.86	21.21
	Q_{Pu} (lpm)	60 Hz	8.70	10.31	12.73	17.56	21.43	25.46
MPN 404	Pressure p_{max}	(bar)	250	250	250	240	195	165
	Delivery flow	50 Hz	7.30	8.66	10.68	14.74	17.99	21.37
	Q_{Pu} (lpm)	60 Hz	8.76	10.39	12.82	17.69	21.58	25.64

Table 12: Internal gear wheel version with 1~phase motor

Basic type	Parameters Size 2	Delivery flow coding, geom. displacement, perm. pressure, delivery flow					
		IZ 7,5	IZ 9,1	IZ 11,9	IZ 16,2	IZ 19,2	IZ 22,9
	Delivery flow coding						
	Geom. displacement V_g (cm ³ /rev.)	5.40	6.40	7.90	10.90	13.30	15.80
MPNW 42	Pressure p_{max} (bar)	70	60	50	35	30	25
	1) Delivery flow Q_{Pu} (lpm) 50 Hz	14.82	17.56	21.68	29.91	36.50	43.26
MPNW 44	Pressure p_{max} (bar)	180	150	120	90	70	60
	1) Delivery flow Q_{Pu} (lpm) 50 Hz	7.28	8.62	10.65	14.69	17.92	21.29

1) **Note:** The 1~phase version will not start-up while pressurized (see sect. 3.2)

2.2 Dual circuit pumps (double pumps)

Combination of pumps listed in tables at sect. 2.1.1 and 2.1.2

2.2.1 Double high pressure pump version

Combination of 2-times three pump elements; For delivery flow and pressure rating, see tables 7+8

Order example: MPN 42 - **H H 1,25/6,5** - B 25.20 KS - 3x400/230 V 50 Hz

**Table 13:** Delivery flow coding

Delivery flow coding	0,9	1,25	1,5	2,5	3,6	4,3	5,1	5,6	6,5
Geom. displacement V_g (cm ³ /rev.)	0.64	0.88	1.15	1.79	2.58	3.03	3.51	4.03	4.58

2.2.2 Combination high and low pressure pump

Combination high pressure pump (2-, 3-, or 6 pump elements) acc. table 7+8 and low pressure pump table 9

Order example: MP 404 - **H Z 11,5/87** - B 110.80 DT - 3x400/230 V 50 Hz

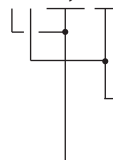

Coding for gear pumps,
acc. to table 9

Coding for radial piston pumps,
acc. to table 7

2.3 Tanks

Size	Tank or cover plate	Connection pedestal	Pump version				
			H HH	Z	IZ	HZ with Z Size 1 Size 2	HZ with Z Size 3
MPN(W) 42	B10., D10.	20	●	up to Z 9,8			
	B25., D25.	20	●	up to Z 45	●	●	
		80 90					
	B55., D55.	20	●	●	●	●	
80 90 160							
B110., D55.	20 80 90 160	●	●	●	●	●	
MPN 44	B 10., D10.	20	●	up to Z 21			
	B25., D25.	20	●	●	●	●	
		80 90 160					
	B55., D55.	20	●	●	●	●	
80 90 160							
B110., D55.	20 80 90 160	●	●	●	●	●	
MPN(W) 44 MPN 46 MPN 48	B10., D10.	20	●	up to Z 21			
	B25., D25.	20	●	●	●	●	
		80 90 160					
	B55., D55.	20	●	●	●	●	
80 90 160							
B110., D55.	20 80 90 160	●	●	●	●	●	
MPN 404	B10.	20	●				
	B25., D25.	20	●	●	●		
		80 90 160					
	B55., D55.	20	●	●	●		
80 90 160							
B110., D55.	20 80 90 160	●	●	●	●	●	

Selection notes connection pedestal

- 20 - suitable for flows up to approx. 20 lpm
- all connection blocks acc. to D 6905 A/1, D 6905 B D 6905C and D 6905 TÜV can be mounted
- 80, 160 - suitable for flows up to approx. 80 lpm or 160 lpm
- all connection blocks acc. to D 6906 can be mounted
- 90 - suitable for flows up to approx. 90 lpm
- only available at dual stage pumps for mounting of valves type CR 4 acc. to D 7150 and type NE 70 acc. to D 7161

For connection pedestal, see sect. 4.4

3. Additional data

3.1 General information

Nomenclature	Constant delivery pump
Design	Valve controlled, radial piston pump (2-, 3- or 6-cylinders or gear pump)
Direction of rotation	Radial piston pump - any Gear pump - counterclockwise (single circuit pump) Gear pump - clockwise (dual circuit pump) (The rotation direction can be detected only by checking the delivery flow, when there is no flow the rotation direction has to be reversed by interchanging the connection of two of the three main wires of the 3-phase motor)
Installed position	Vertical, installed in a tank (motor must be fluid immersed all-time, see sect. 5.1)
Fastening	Single circuit pump - via brackets at the cover plate Cover plate version - dep. on installation either on frame or tank Tank - see dimensional drawings
Mass (weight) approx. in kg	m = motor + radial piston pump + gear pump + cover plate + tank + (connection blocks)

Motor							
Type	MPN 42	MPN 44	MPN 46	MPN 48	MPN 404	MPNW 42	MPNW 404
Mass (kg)	12.8	12.8	13.3	13.3	19.9	12.8	14.8

Radial piston pump	Number of pump elements		
	2	3	6
H (single circuit pump)	2.8	4.8	5.5
HH (dual circuit pump)	-	-	5.5

Gear pump (kg)	
Z 2,0	
Z 2,7	1.95
Z 3,5	
Z 4,5	2.0
Z 5,2	2.1
Z 6,9	
Z 8,8	2.2
Z 9,8	
Z 11,3	2.3
Z 14,4	2.4
Z 6,5	
Z 9,0	2.8
Z 12,3	
Z 16	
Z 21	3.25
Z 24	
Z 28	3.3
Z 37	3.5
Z 45	6.7
Z 59	7.7
Z 75	
Z 87	8.1

Internal gear pump (kg)	
IZ 7,5	2.9
IZ 9,1	3.0
IZ 11,9	3.1
IZ 16,2	3.3
IZ 19,2	3.5
IZ 22,9	3.6

Cover plates	Mass (kg)	Tank	Mass (kg)	Connection blocks	Pamphlet
D10 ...	1.75	B10 ...	6.75	A	D 6905 A/1
D25 ...	2.85	B25 ...	10.40	B	D 6905 B
D55 ...	6.15	B55 ...	15.85	C	D 6905 C, Sk 6906 C
		B110 ...	19.20	BA	D 7788
				VB	D 7302
				BVZP	D 7785 B/1
				BWN, BWH	D 7470 B/1

3.2 Hydraulic data

Pressure	Pressure side (port P): Depending on delivery flow, see sect. 2 Suction side (inside the tank): Ambient air pressure, tank not suited for charging!															
Start-up against pressure	The version for 3~phase mains can start-up against pressure p_{max} . Attention: The versions for 1~phase (AC) may only start against a very low pressure. Therefore the controls must enable a pressureless start e.g. by means of an idle circulation solenoid valve, which is held open during start and blocks again after a period of approx. 0.5...1sec (e.g. by via a delay relays).															
Pressure fluid	Hydraulic oil conforming DIN 51524 part 1 to 3: ISO VG 10 to 68 conform. DIN 51519. Opt. service: approx. 10 ... 500 mm ² /s Viscosity during start min. approx. 4; max. approx. 800 mm ² /s Also suitable are biologically degradable pressure fluids type HEES (Synth. Ester) at service temperatures up to approx. +70°C. Electrically hazardous: Any fluid types containing water (HEPG, HETG etc.) must not be used (short-cut)!															
Temperature	Ambient: approx. -40 ... +60°C. Fluid: -25 ... +80°C, note the viscosity range ! Permissible temperature during start: -40°C (observe start-viscosity!), as long as the service temperature is at least 20K (Kelvin) higher for the following operation. Biologically degradable pressure fluids: Observe manufacturer's specifications. By consideration of the compatibility with seal material not over +70°C.															
Total and usable filling volume	<table border="1"> <thead> <tr> <th>Tank size</th> <th>Filling volume $V_{filling}$ (l)</th> <th>Usable filling volume V_{usable} (l)</th> </tr> </thead> <tbody> <tr> <td>B 10</td> <td>17.0</td> <td>10.0</td> </tr> <tr> <td>B 25</td> <td>37.0</td> <td>30.0</td> </tr> <tr> <td>B 55</td> <td>75.0</td> <td>55.0</td> </tr> <tr> <td>B 110</td> <td>100.0</td> <td>75.0</td> </tr> </tbody> </table>	Tank size	Filling volume $V_{filling}$ (l)	Usable filling volume V_{usable} (l)	B 10	17.0	10.0	B 25	37.0	30.0	B 55	75.0	55.0	B 110	100.0	75.0
Tank size	Filling volume $V_{filling}$ (l)	Usable filling volume V_{usable} (l)														
B 10	17.0	10.0														
B 25	37.0	30.0														
B 55	75.0	55.0														
B 110	100.0	75.0														

3.3 Electrical data

Data apply to radial piston and gear pumps	
The drive motor and the pump are designed as an inseparable unit, see description in sect. 1	
Connection	Versions with plug Co. HARTING, leads = 1.5 mm ² Versions with integrated terminal box, (cable gland M 20x1.5 is not scope of delivery)
	Individual pumps (motor/pump-combination): Lead length 0.6 m, for cable identification, see page 13
	3~phase mains: 6 x Φ 0.82 mm ²
	1~phase mains: Main winding 2 x Φ 2.08 mm ² Auxiliary winding 2 x Φ 0.82 mm ² Winding protection contact switch 2 x Φ 0.52 mm ²
Protection class	IP 54 conf. IEC 60529, apply to the complete hydraulic power pack (as a reference protection class to pure electrical machinery)
Protection against accidental contact	IEC 61140 safety class I
Insulation	Design conf. VDE 0110
	<ul style="list-style-type: none"> ● for mains with 4 or 3 conductors L1-L2-L3-PE (3~phase mains) with grounded neutral point up to 500 V AC nom. phase voltage conductor - conductor ● for mains with 4 or 3 conductors L1-L2-L3 (3~phase mains) without grounded neutral point up to 300 V AC nom. phase voltage conductor - conductor ● for 1~phase mains with 2 conductors L-N up to 300 V AC nom. voltage.

Type	Nom. voltage and circuitry U_N (V)	Mains frequency f (Hz)	Nominal power P_N (kW)	Speed n_N (rpm)	Nom. current I_N (A)	Start current ratio I_A / I_N	Power factor $\cos \varphi$	Insulation material class
MPN 42	400/230 $\Upsilon\Delta$	50	2.1	2785	4.9/8.4	4.8	0.87	B
	460/265 $\Upsilon\Delta$	60	2.5	3380	4.8/8.3	5.4	0.88	
MPN 44	400/230 $\Upsilon\Delta$	50	2.1	1360	4.9/8.5	4.1	0.86	B
	460/265 $\Upsilon\Delta$	60	2.4	1632	4.6/8.0	4.6	0.86	
MPN 46	400/230 $\Upsilon\Delta$	50	3.0	2815	6.4/11.0	5.7	0.88	B
	460/265 $\Upsilon\Delta$	60	3.6	3410	6.3/11.3	6.2	0.89	
MPN 48	400/230 $\Upsilon\Delta$	50	3.0	1370	6.7/11.5	4.2	0.84	B
	460/265 $\Upsilon\Delta$	60	3.6	1665	6.6/11.3	4.7	0.85	
MPN 404	400/230 $\Upsilon\Delta$	50	4.2	1370	9.2/16.0	5.0	0.88	B
	460/265 $\Upsilon\Delta$	60	5.0	1660	6.6/11.3	5.6	0.89	
MPNW 42 ¹⁾	230 $C_B = 50 \mu F$	50	1.9	2715	13.5	3.0	0.95	B
MPNW 44 ¹⁾	230 $C_B = 70 \mu F$	50	1.9	1330	13.5	2.9	0.95	B

¹⁾ The capacity of the operating capacitor should be reduced by approx. 30%, when less than 75% of the hydraulic work ($p_{max} \cdot V_g$) is employed.

Voltage ranges

Operation with reduced supply voltage is possible, but see „Performance restrictions“!

Nom. voltage	Perm. mains voltage tolerances	
	50 Hz	60 Hz
Standard	3 ~ 400 V 50 Hz 3 ~ 230 V 50 Hz	± 10% ± 5%
	1 ~ 230 V 50 Hz	± 10% -

Performance restrictions

The table shows correction factors for reduced mains supply voltage. Take the correction factor for the lowest voltage anticipated.

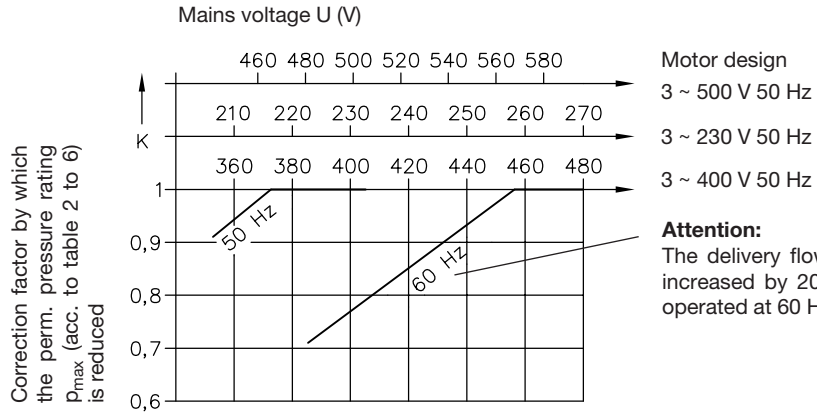

Motor design
3 ~ 500 V 50 Hz
3 ~ 230 V 50 Hz
3 ~ 400 V 50 Hz

Attention:
The delivery flow will be increased by 20% when operated at 60 Hz!

Temperature switch

Technical data:

Bimetallic switch Co. MICROTHERM
T10V 80°C ±5K U112 P102 L510-NC-contact
AC: 250 V 50/60 Hz 3.5 A; DC: 42 V 1 A



Signaling takes place at 80°C ±5K (Kelvin)
Max. voltage 250V 50/60 Hz
Nom. current (cos φ ~ 0.6) 1.6 A
Max. current at 24V DC 1.5 A
Connection – in the terminal box / plug Co. HARTING

Note: The temperature switch is integrated in the winding at 1~phase motors i.e. winding protective switch

Float switch

Technical data:

Switching performance DC/AC 60 W/ 60 VA
max. current DC/AC 0.8 A (cos φ =1)
max. voltage 230 V 50/60 Hz

A protective circuitry is mandatory at inductive loads

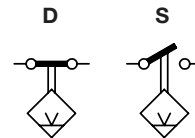

Connection via separate plug (DIN 43650-C, 8 mm)

4. Unit dimensions

All dimensions in mm, subject to change without notice!

4.1 Single circuit pumps

Version with radial piston pump

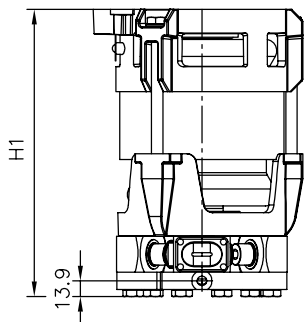

	MPN 42 MPNW 42	MPN 44	MPN 46	MPN 48 MPNW 44	MPN 404
H1	246.4	253.4	267.4	276.4	308.4

Port P = G 1/8 ISO 228/1 (BSPP);
 Accessory Adapter G 1/8 - M16x1.5 for pressure hose
 (optional order) part No. 30264075-00
 Cable length = approx. 0.6 m

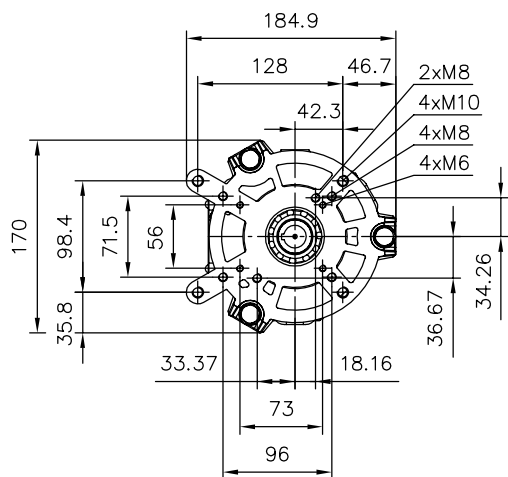

Cable identification

3~phase mains		1~phase mains	
U1:	blue BU	U1:	blue BU
U2:	violet VT	U2:	brown BN
V1:	brown BN	Z1:	red RD
V2:	red RD	Z2:	black BK
W1:	black BK	Winding protective switch	
W2:	orange OG		blue BU

Version with gear pump

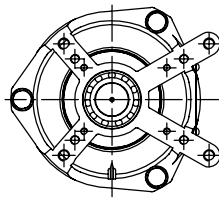
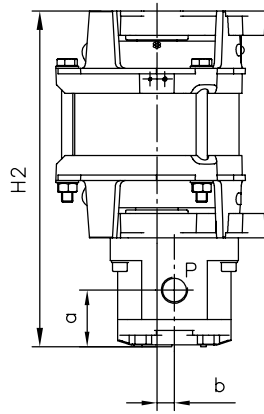
For missing dimensions,
see at radial piston pump

Gear pump Size	MPN 42 MPNW 42	MPN 44	H 2			Pressure and suction ports (BSPP)		a	b		
			MPN 46	MPN 48 MPNW 44	MPN 404	P	S				
Z 2,0	260.3	267.3	281.3	290.3	322.3	G 3/8	34.9	11.3			
Z 2,7	261.9	268.9	282.9	291.9	323.9		35.7				
Z 3,5	263.5	270.5	284.5	293.5	325.5		36.5				
Z 4,5	265.5	272.5	286.5	295.5	327.5		37.5				
Z 5,2	268.3	275.3	289.3	298.3	330.3		38.8				
Z 6,9	271.5	278.5	292.5	301.5	333.54		40.5				
Z 8,8	275.5	282.5	296.5	305.5	337.5		42.5				
Z 9,8	275.5	282.5	296.5	305.5	337.5		42.5				
Z 11,3	281.0	288.0	302.0	311.0	343.0		45.2				
Z 14,4	287.5	294.5	308.5	317.5	349.5		48.5				
Z 6,5	286.0	293.0	307.0	316.0	348.0		G 1/2		G 1/2	47	15.5
Z 9,0	289.0	296.0	310.0	319.0	351.0		G 1/2		G 1/2	50	
Z 12,3	289.0	296.0	310.0	319.0	351.0		G 1/2		G 1/2	50	
Z 16	289.0	296.0	310.0	319.0	351.0		G 1/2		G 3/4	50	
Z 21	313.0	320.0	334.0	343.0	375.0	G 1/2	G 3/4	62			
Z 24	313.0	320.0	334.0	343.0	375.0	G 1/2	G 3/4	62			
Z 28	313.0	320.0	334.0	343.0	375.0	G 1/2	G 3/4	62			
Z 37	325.0	332.0	346.0	355.0	387.0	G 3/4	G 1	67.7			
Z 45	333.0	340.0	354.0	363.0	395.0	G 3/4	G 3/4	76	21.7		
Z 59	342.0	349.0	363.0	372.0	404.0	G 3/4	G 1	85			
Z 75	352.0	359.0	373.0	382.0	414.0	G 3/4	G 1	81			
Z 87	352.0	359.0	373.0	382.0	414.0	G 1	G 1/4	81			

Version with internal gear pump

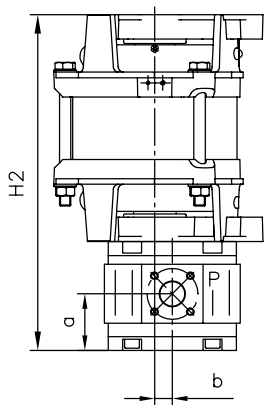

Size	H 2					a	b
	MPN 42 MPNW 42	MPN 44	MPN 46	MPN 48 MPNW 44	MPN 404		
IZ 7,5	328.9	335.9	335.9	358.9	390.9	43	17
IZ 9,1	330.9	337.9	351.9	360.9	392.9	44	
IZ 11,9	333.9	340.9	354.9	363.9	395.9	45.5	
IZ 16,2	339.9	346.9	360.9	369.9	401.9	48.5	
IZ 19,2	344.9	351.9	365.9	374.9	406.9	51	
IZ 22,9	349.9	356.9	370.9	379.9	411.9	53	

Pressure port

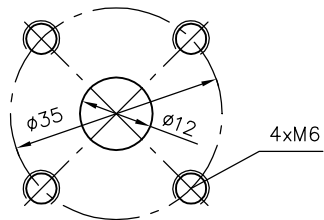

Pressure flange adapter HAWE No. 6013 3407-00

Suction port

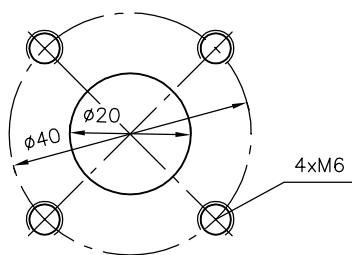

Suction flange adapter HAWE No. 6013 3407-00

4.2 Dual circuit pumps

Version with radial piston/gear pump combination (high/low pressure pump)

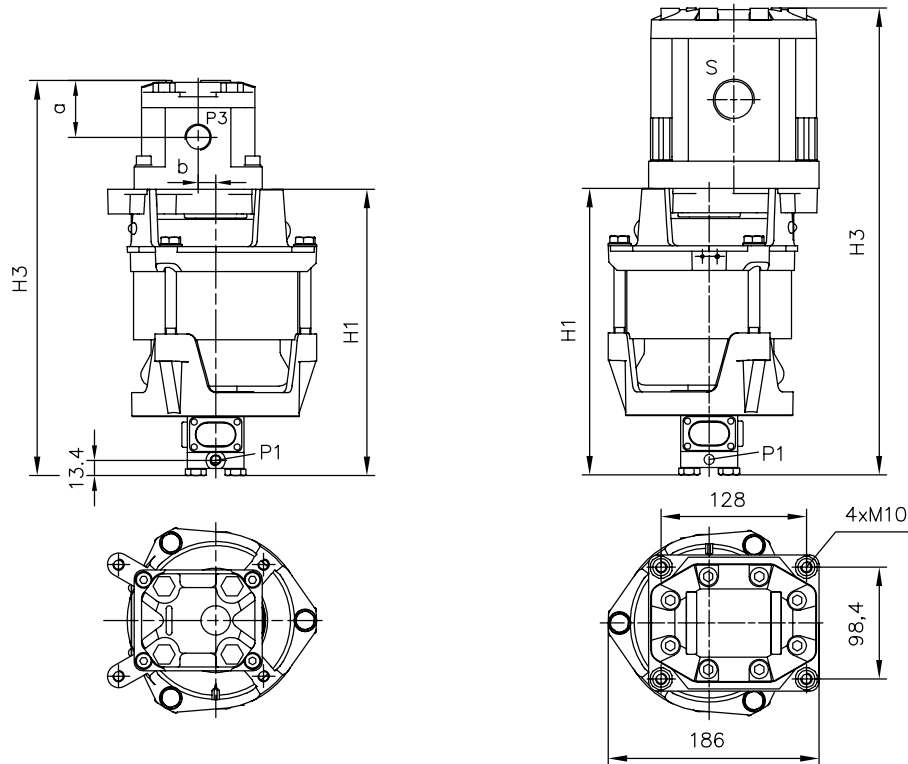

Ports:
 P1, P3 = G 1/4
 ISO 228/1 (BSPP)
 S = according to gear
 pump, see page 14

For missing dimensions, see
 radial piston or gear pump
 (dimensions a and b)

Gear pump Size	H3				
	MPN 42 MPNW 42	MPN 44	MPN 46	MPN 48 MPNW 44	MPN 404
Z 2,0	313.7	320.7	334.7	343.7	375.7
Z 2,7	315.3	322.3	336.3	345.3	377.3
Z 3,5	316.9	323.9	337.9	346.9	378.9
Z 4,5	318.9	325.9	339.9	348.9	380.9
Z 5,2	321.7	328.7	342.7	351.7	383.7
Z 6,9	324.9	331.9	345.9	354.9	386.9
Z 8,8	328.9	335.9	349.9	358.9	390.9
Z 9,8	328.9	335.9	349.9	358.9	390.9
Z 11,3	334.4	341.4	355.4	364.4	396.4
Z 14,4	340.9	347.9	361.9	370.9	402.9
Z 6,5	339.4	346.4	360.4	369.4	401.4
Z 9,0	342.4	349.4	363.4	372.4	404.4
Z 12,3	342.4	349.4	363.4	372.4	404.4
Z 16	342.4	349.4	363.4	372.4	404.4
Z 21	366.4	373.4	387.4	396.4	428.4
Z 24	366.4	373.4	387.4	396.4	428.4
Z 28	366.4	373.4	387.4	396.4	428.4
Z 37	378.4	385.4	399.4	408.4	440.4
Z 45	386.4	393.4	407.4	416.4	448.4
Z 59	395.4	402.4	416.4	425.4	457.4
Z 75	405.4	412.4	426.4	435.4	467.4
Z 87	405.4	412.4	426.4	435.4	467.4
Z 110	413.4	420.4	434.4	443.4	475.4
Z 135	424.4	431.4	445.4	454.4	486.4
Gear pump	MPN 42 MPNW 42	MPN 44	MPN 46	MPN 48 MPNW 44	MPN 404
H1	246.4	253.4	267.4	276.4	308.4

Version with radial piston/radial piston pump combination (high/high pressure pump)

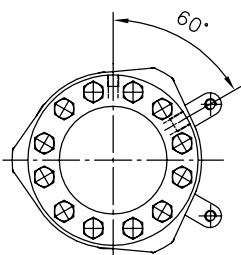

	MPN 42 MPNW 42	MPN 44	MPN 46	MPN 48 MPNW 44	MPN 404
H4	251.4	258.4	272.4	281.4	313.4

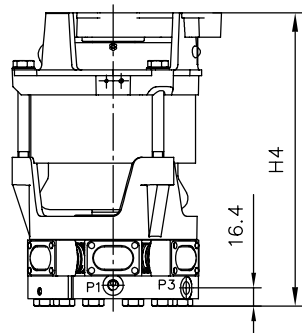

Ports P1 = G 1/8 ISO 228/1 (BSPP);
 Accessory Adapter G 1/8 (BSPP)- M16x1.5 for pressure
 (optional order) hose part No. 30264075-00
 P3 = G 1/4 ISO 228/1 (BSPP)

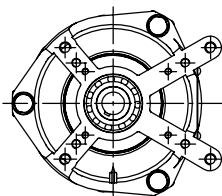

For missing dimensions,
 see radial piston pump

4.3 Tank and cover plate versions

Tank **B10**, cover plate **D10**

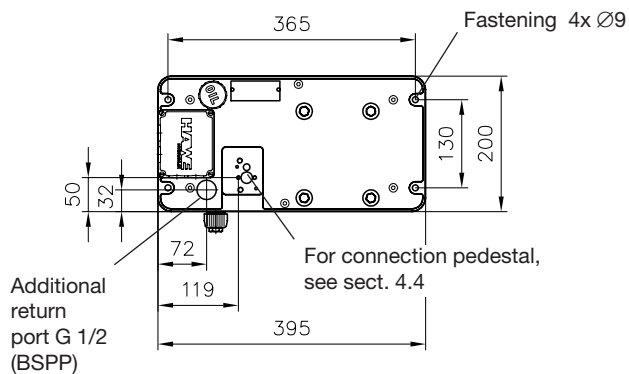
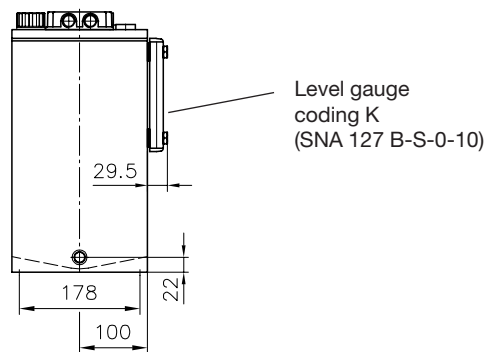
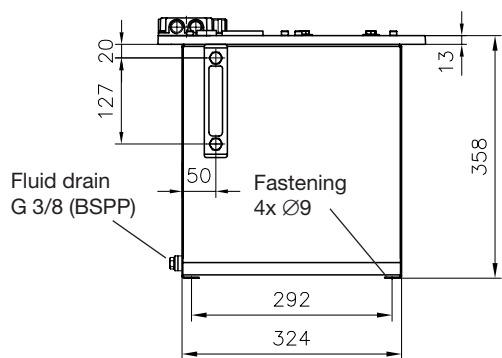

For dimension a and b, see sect. 4.4
 (dep. on the connection pedestal)

Tank **B25**, cover plate **D25**

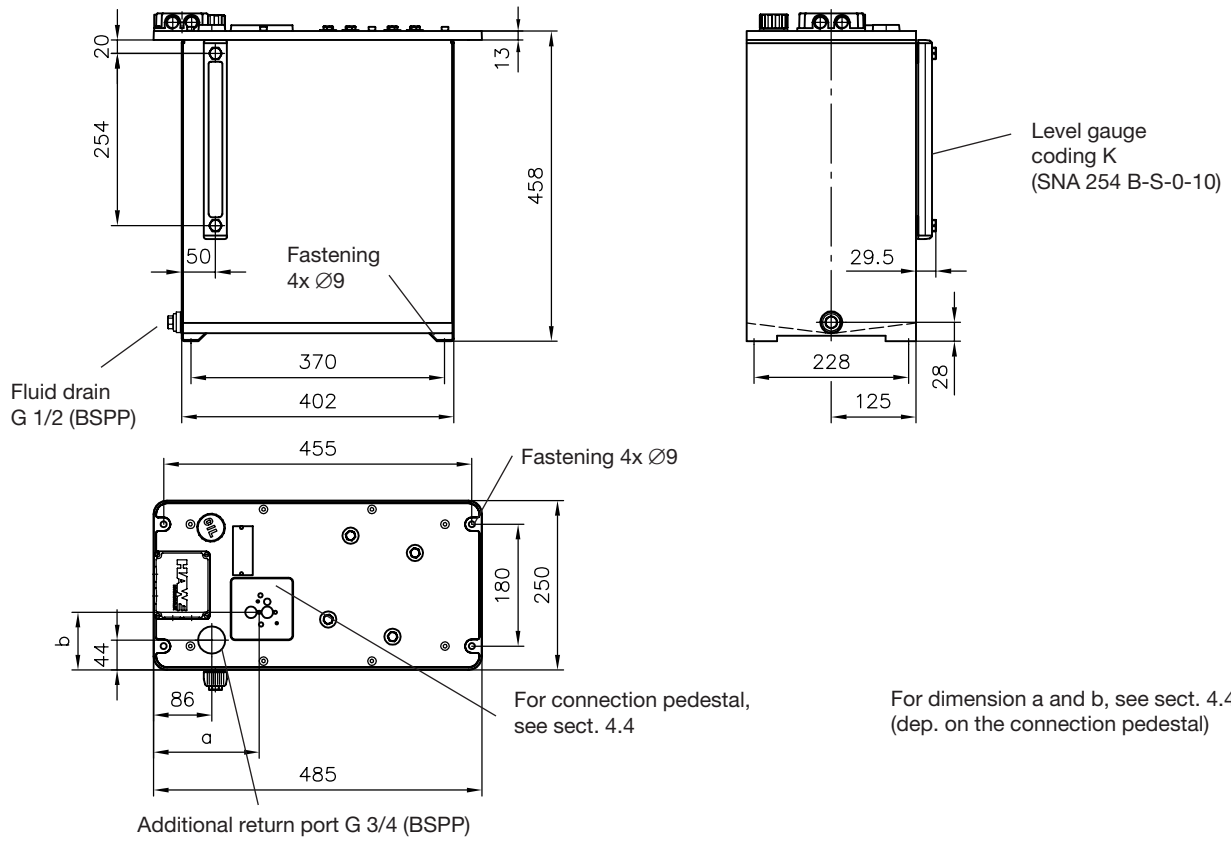

Tank **B55**, cover plate **D55**

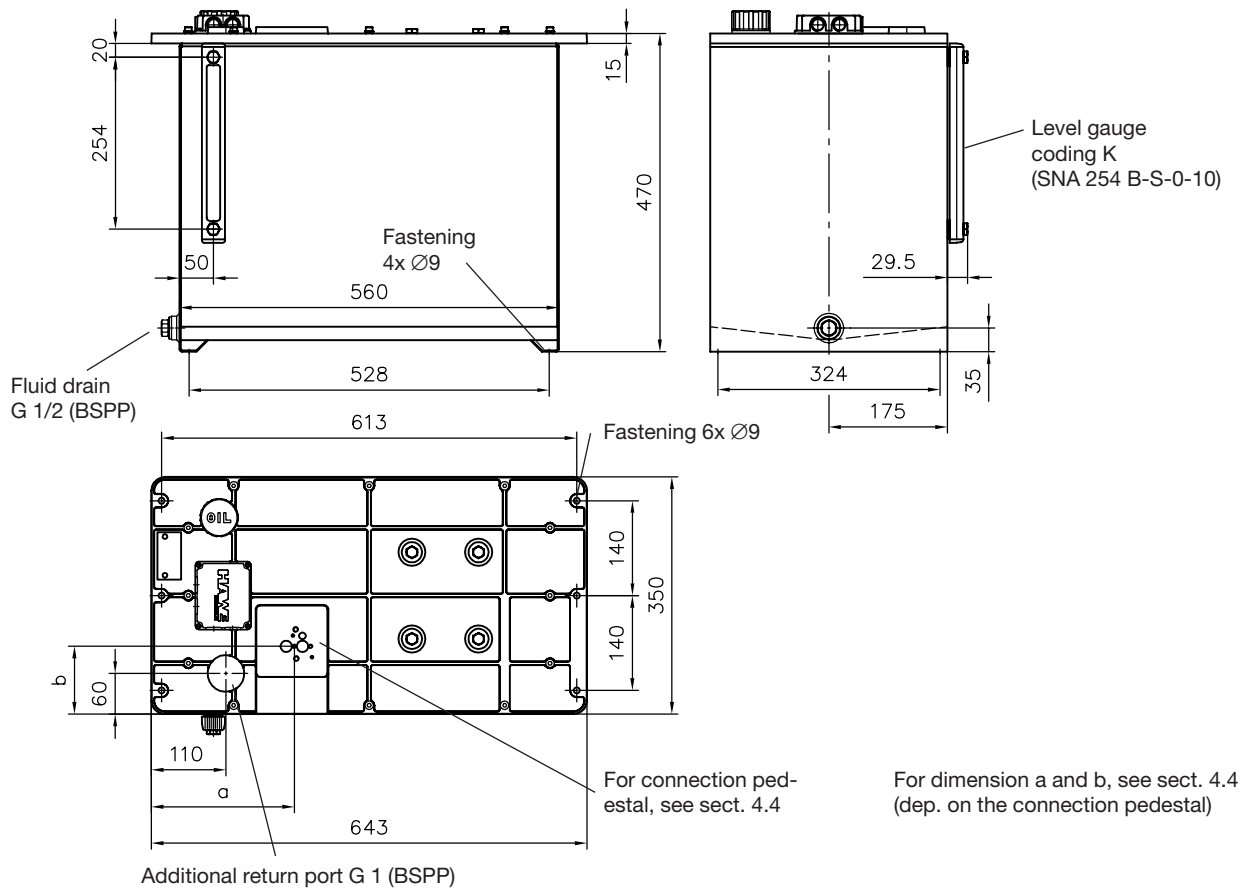

Tank B110, cover plate D55

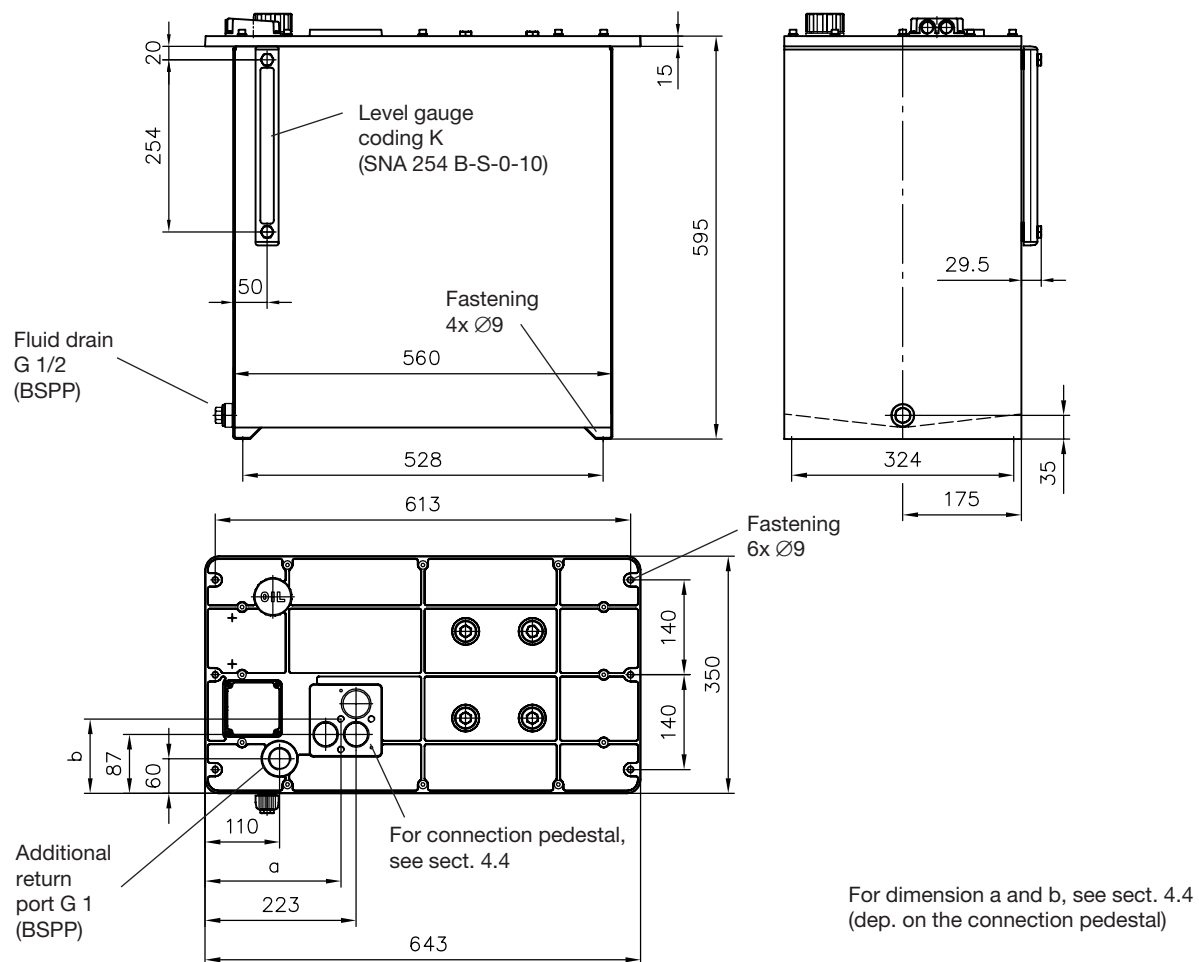

Required mounting area when cover plate versions are used at customer furnished tanks
for cover plate D10

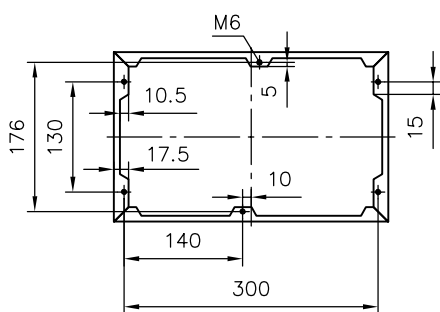

Continuation Required mointing area when cover plate versions are used at customer furnished tanks

for cover plate **D25**

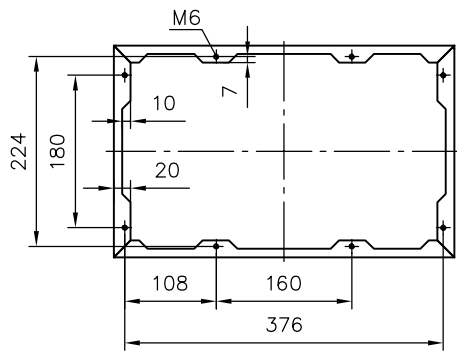

for cover plate **D55, D110**

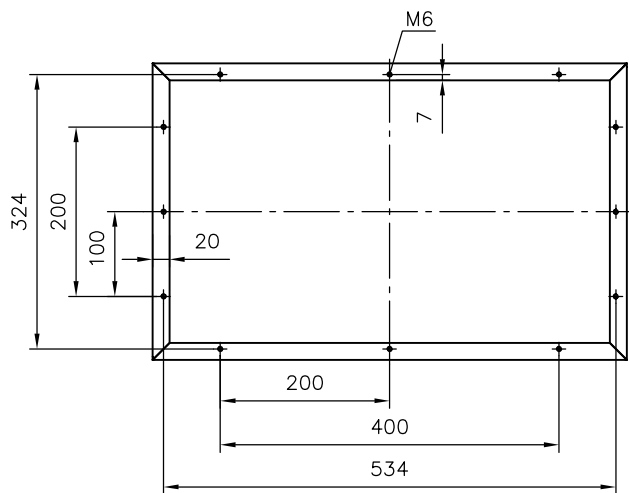

4.4 Hydraulic and electric connections

Hydraulic connections

Coding **B(D)... .20**
for flow up to approx. 20 lpm

Single circuit pumps H, Z

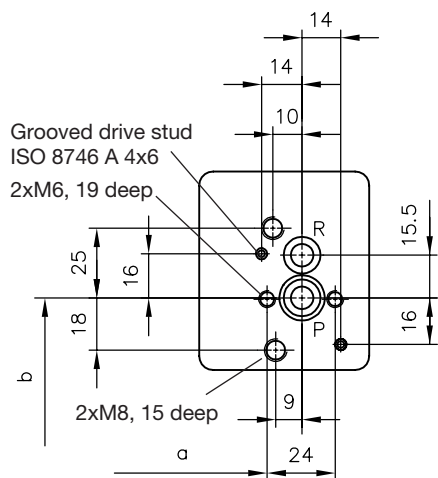

Ports
P, P1, P3: O-ring 8x2 NBR 90 Shore
R: O-ring 9x2 NBR 90 Shore

Tank / Cover plate

	a	b
B10.20, D10.20	119	50
B25.20, D25.20	156	85
B55.20, D55.20	211	100
B110.20, D55.20	211	100

Dimension a: to the end (short side of the cover plate)
b: to the end (wide side of the cover plate)
see sect. 4.3

Dual circuit pumps HH, HZ

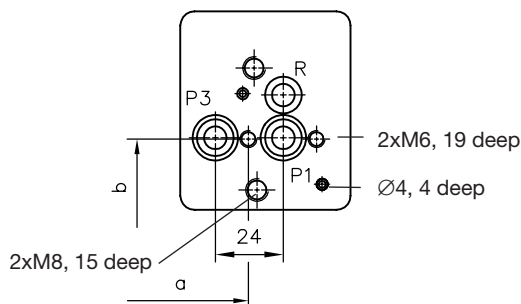

Coding **B(D)... .80** and **.160** suited for connection blocks C 80, C 81, C 160, C 161 see sect. 4.5
(for flow up to 80 or 160 lpm)

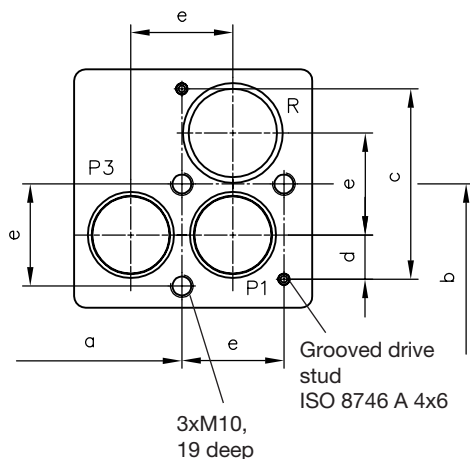

Tank / Cover plate

	Q _{max} (lpm)	a	b	c	d	e	Ports O-ring NBR Shore
B25.80, D25.80	80	164	91	60	16	32	P1,P3: 18x2
B55.80, D55.80	80	207	116	60	16	32	R: 26x2
B55.160, D55.160	160	202.5	99.5	84	22.5	45	P1,P3: 22x2
B110.160, D55.160	160	202.5	99.5	84	22.5	45	R: 39.34x2.62

Dimension a: to the end (short side of the cover plate)
b: to the end (wide side of the cover plate)
see pos. 4.3

Coding **B(D)... .90** suited for combination with type CR 4 M and type NE 70
(for flow up to 90 lpm)

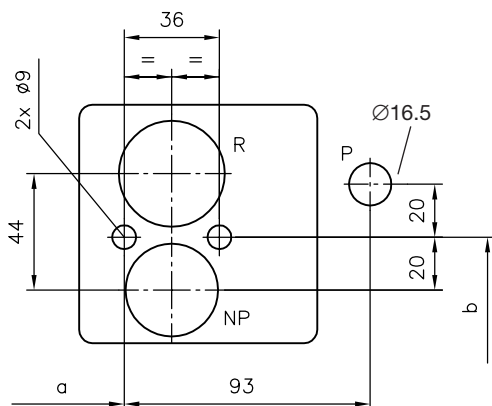

For additional information, see:

Two stage valves type NE 70 acc. to D 7161
Switch units type CR 4 M acc. to D 7150

Tank / Cover plate

	Q _{max} (lpm)	a	b
B25.90, D25.90	90	132	85
B55.90, D55.90		192	100
B160.90, D55.90		192	100

Dimension a: to the end (short side of the cover plate)
b: to the end (wide side of the cover plate)
see pos. 4.3

Electrical connection

Terminal box

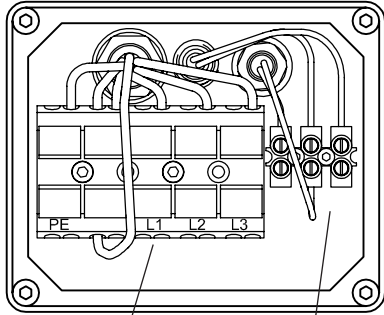

Connections to be performed by the customer

Temperature and/or fluid level switch

Fluid level or temperature switch

D(S) or T

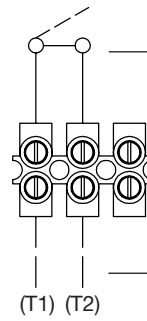

Pre-connected at HAWE Hydraulik

Connections to be performed by the customer

Fluid level and temperature switch

D(S)T

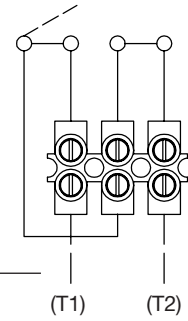

Version for 3~phase mains

Y-circuitry

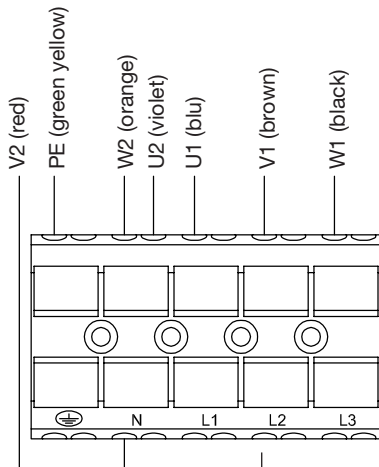

Pre-connected at HAWE Hydraulik

Δ-circuitry

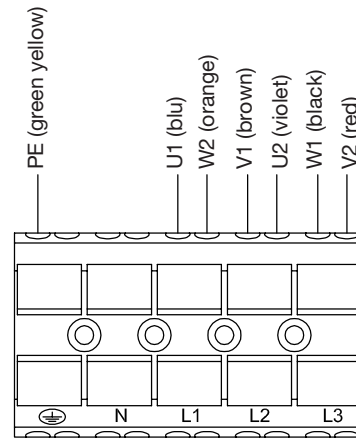

Connections to be performed by the customer

Version for 1~phase mains

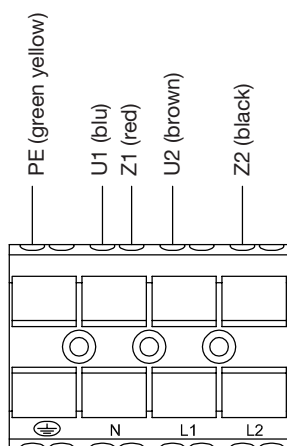

Pre-connected at HAWE Hydraulik

Connections to be performed by the customer

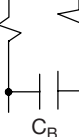

The operating capacitor C_B is not scope of delivery.

Plug Co. Harting

Terminal box

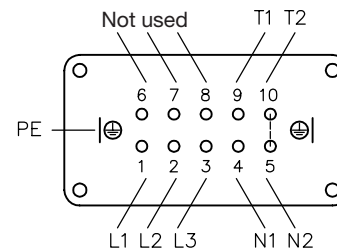

4.5 Connection blocks (Overview)

The hydraulic power packs can be delivered together with connection blocks as well as with additional directional valves to form a hydraulic power pack unit which is completely assembled for immediate use (see example on page 1).
For technical data, dimensions and further examples refer to the specified pamphlets.

Pamphlet	Coding	Port thread ISO 228/1 (BSPP)	Pressure range from ... to (bar) 1)	Flow (lpm)	Integrated functional elements 12)			Brief notes concern- ing the connection block	Suitable di- rectional valve banks for direct mounting 1)
					Pressure limiting valve	Idle cir- culation valve	Return filter		
D 6905 C	C5 C6	G 1/4 G 3/8	700 700	12 28	no no	no no	no no	Simple connection block	No possibility for mounting
D 6905 B	B../...-...	G 1/4 to G 1/2	450 (700)	8 ... 25	yes	no	no	For single acting lifting or clamping devices 1) 2)	
D 6905 A/1	A1../.. to A4../..	G 1/4	(0) ... 700 in steps dep. on type	12	yes	no	no	Most frequently used connection block with pressure limiting valve	1a) 1b)
	A13../.. to A43../..	G 3/8		18	yes	no	no		2)
	A51../.. and A61../..	G 3/8		18	yes	no	no		3)
	AS(V)1../.. to AS(V)4../..	G 1/4	(0) ... 450 in steps dep. on type	18	yes	yes	no	With idle circulation valves acc. to D 7490/1	1a) 1b)
	AL11(12)../..	G 1/4	51 ... 350 in steps dep. on type	12	yes 4)	yes 4)	no	Automatic idle circu- lation 4) (accumulator charging valve)	1a) 8)
	A..F../.. AS..F../.. AM..F../.. AK..F../.. AL21F../.. A...D../..	G 1/4 to G 1/2 depending on type and port	(0) ... 700 in steps dep. on type	15 ... 33 depend. on filler size	yes 5)	yes 6)	yes 7)	Autom. idle circulation 4) (accumulator charging valve) With return filters 12 µm nom. 50%/30 µm abs. or pressure resistant 10 µm ($\beta_{10} = 75$) with AL...D../.. and idle circu- lation valves, see 6)	4) 8)
	AP1../.. and AP3../..	G 1/4	5 ... 700	20	yes	yes 9)	no	Prop. pressure limiting valve	1a) 1b)
D 6905 TÜV	AX, ASX, APX	G 1/4	80 ... 450	6 ... 10	yes	no	no	Pressure limiting valve with unit approval	
D 6906 Sk 6906 C	C 80 C 81 C 160 C 161	R P(1) P3 G 1 G 3/4 G 1/4 G 3/4 G 1/2 G 1 G 1 G 3/8 G 1 G 1	0 ... 250 0 ... 250 0 ... 250	0 ... 80 0 ... 80 0 ... 160	no no no	no no no	no no no	For pipe connection at dual circuit pumps: C 80 and C 160 at single circuit pumps: C 81 and C 161	No possibility for mounting
D 7150	CRM4	A, R G1 HP G 3/4 NP, M G 1/4		0 ... 8 0 ... 80 A → R 0 ... 200	yes	no	no	With automatic pre-relief at dual stage circuits (high/low pressure)	No possibility for mounting
D 7161	NE70	A, R G1 HP G 1/4 NP G 3/4	High pressure 0 ... 400 Low pressure 0 ... 60	0 ... 16 0 ... 100	yes	no	no	For the control of dual circuit pumps feeding one pressure line	3)
D 7230	SKC11../.. to SKC14../..	G 1/4 and G 3/8	200...400 10)	12 ... 20	yes	yes 11)	no	Integrated directional spool valve	
D 7450	SWC1	G 1/4	315	12	yes	yes 11)	no	Integrated directional spool valve	Add-on spool valve acc. to D 7450 or Sk 7450 W

For foot notes, see page 24

Continuation: Connection blocks

①a BWN(H)1F... acc. to D 7470 B/1
 BWH2F... acc. to D 7470 B/1
 BVZP1F... acc. to D 7785 B

①b VB01(11)F... acc. to D 7302
 SWR(P)1F... acc. to D 7450
 SWR2F... acc. to D 7451
 SWS2F... acc. to D 7951

② BWH3F... acc. to D 7470 B/1

③ VB11G... and
 VB21G... acc. to D 7302

④ BWN(H)1F... acc. to D 7470 B/1
 BWH2F... acc. to D 7470 B/1
 BVZP1F... acc. to D 7785 B
 VB01(11)F... acc. to D 7302
 SWR(P)1F... acc. to D 7450 ⁸⁾
 SWR2F... acc. to D 7451 ⁸⁾
 SWS2F... acc. to D 7951 ⁸⁾

- 1) It should be kept in mind that the directional valve banks which can be directly mounted may have a max. permissible pressure below 700 bar.
- 2) Should be used for intermittent service only
- 3) The valves are directing radially to the outside
- 4) Hydraulic cut-off function acts as pressure limitation also
- 5) Depending on type also with additional proportional pressure limiting valve
- 6) Idle circulation valve acc. to D 7490/1 at AS..., acc. to D 7470 A/1 at AK... and AM..., with automatic idle circulation (accumulator charging valve) with AL21...
- 7) with pressure filter at A...D.../...
- 8) Directional spool valve banks type SWR.. and SWS.. are not ideally suited for mounting onto blocks type AL11(12) or AL21..., as the their always apparent leakage would provoke permanent activation. This effect could be minimized by using an accumulator.
- 9) May be used as idle circulation valve if the prop. solenoid is deenergized (approx. 5 bar)
- 10) Depending on actuation and flow pattern
- 11) For directional spool valves with internal connection P→R in idle position
- 12) Pressure limiting valves acc. to D 7000 E/1, 2/2-way directional valves acc. to D 7490/1, optional with additional check valve acc. to D 7445

5. Notes for general lay-out and initial operation
5.1 Installation in customer furnished tanks

The dimensions of a customer furnished tank should be selected in such a way that it is ensured that the motor is always immersed even the max. required fluid volume is removed. This way the performance rating of the power pack can be completely exploited. The perm. performance is reduced if the motor contour is partially or completely above the fluid level. When more than 1/4 of the motor is above the fluid level a no-load operation is no longer permissible but on/off service can be still provided. The thermal balance of the motor has to be checked (via resistance measurement acc. to VDE 0530) if the fluid level drops even further. This temperature (resistance) check has to be undertaken several times until no more temperature rise can be detected; always after a load sequence when the pump has performed some operation cycles. The perm. fluid temperature is approx. 80°C, the perm. winding temperature is approx. 130°C (isolation class B).

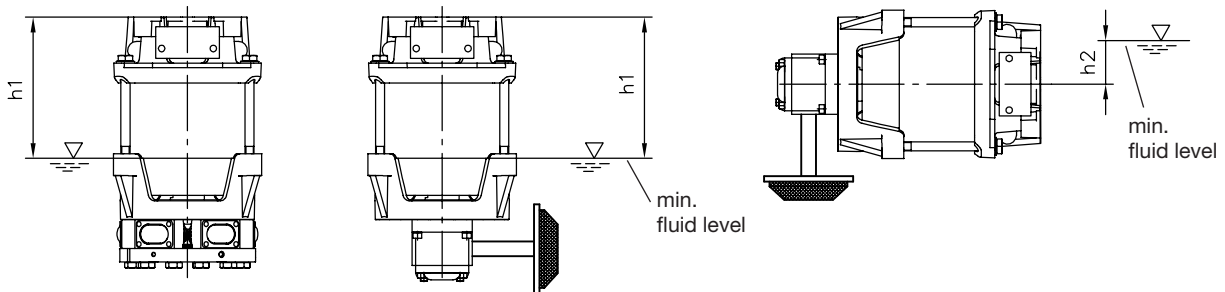

The installed position of the pump is arbitrary, as long as the winding head is immersed below the fluid level h1.

The installed position of the pump is arbitrary, as long as all suction parts are immersed below the fluid level by h2.

h2 = Dependent on size, gear pump and chosen suction part (see dimensional drawings ins sect. 4 and 6)

	MPN 42 MPNW 42	MPN 44	MPN 46	MPN 48 MPNW 44	MPN 404
h1 (mm)	105	113	124	132	163
h2 (mm)	35	35	35	60	60

5.2 Direction of rotation

It is not necessary to observe the direction of rotation with type MPN...-H..., (flow direction will not change) whereas a certain direction of rotation is absolutely required for types MPN.. Z (HZ, IZ). The rotation direction can't be detected in installed state (hydraulic power packs), but via checking the delivery flow. Procedure (gear pumps only): Direct the flow from port P (double pumps feature two ports P!) via a translucent hose back into the tank; Switch on/off the pump several times. When a flow is visible the direction is o.k. otherwise it has to be reversed by interchanging the connection of two of the three main wires of the motor (reversing the rotation direction). Try again! The pumps type MPN.. Z (HZ, IZ) rotate anti-clockwise (facing the drive shaft) in delivery state.

5.3 Motor load at dual circuit pumps

It has to be checked that the product $(pV_g)_{calc.} \leq (pV_g)_{calc. max}$ based on the intended pressure p_1 and p_2 at all three different load situations 1 to 3. The pressure limits p_k, p_w (acc. to sect. 2.1 und 2.2) have to be observed.

Load 1

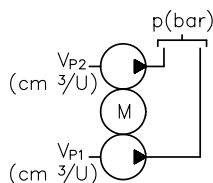

Both pumps work against the same pressure, $p_1 = p_2 = p$

$$(p \cdot V_g)_{calc.} = p \cdot (V_{P1} + V_{P2})$$

Load 2

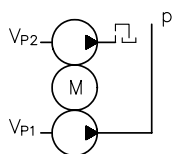

One pump (V_{P1}) works against pressure, the other one is idling, $p_1 = p$

$$(p \cdot V_g)_{calc.} = p \cdot V_{P1} + 3 V_{P2} \cdot 1)$$

Load 3

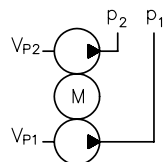

Both pumps work simultaneously but against different pressure

$$(p \cdot V_g)_{calc.} = p_1 \cdot V_{P1} + p_2 \cdot V_{P2}$$

Type	$(pV_g)_{calc. max}$
MPN 42	680
MPN 44	1155
MPN 46	1040
MPN 48	1730
MPN 404	2650
MPNW 42	395
MPNW 44	980

1) A back pressure of approx 3 bar is apparent during idle circulation

5.4 Current consumption

The curves below are one a guideline. They serve to evaluate the current consumption to adjust the motor protective switch (safeguarding overload) and the heat generation to be anticipated (see sect. 5.5).

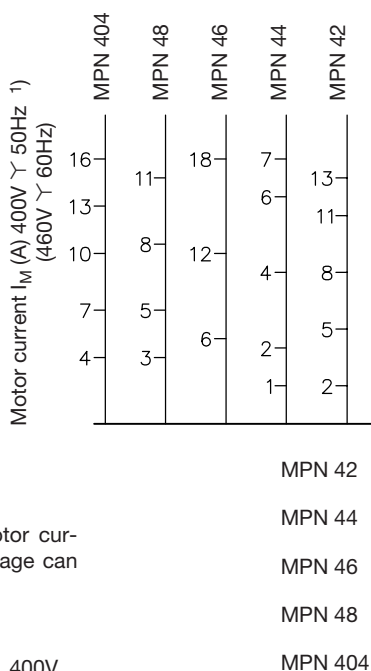

1) Guideline values for the motor current at other than nom. voltage can be easily calculated e.g.

$$\text{Mains 230V 50 Hz: } I_{230V} \approx I_{400V} \cdot \frac{400V}{230V}$$

$$\text{Mains 500V 50 Hz: } I_{230V} \approx I_{400V} \cdot \frac{400V}{500V}$$

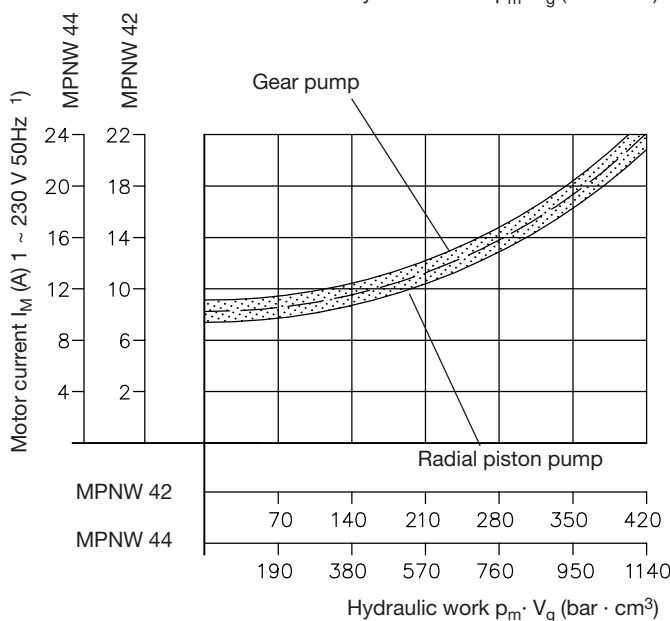

5.5 Built-up of heat

The persistent service temperature to expect for compact hydraulic power packs type MPN depends largely on the local operating conditions. A simple coherence valid for all operating conditions does not exist. The following determination of the most likely expected inertia excess temperature or the permissible relative duty cycle is only a rough guide line and does only apply to circuits without other significant throttling devices (cycle steps including starting against pressure limiting valves, pressure control valves or throttling valves). A test for evaluating the persistent service temperature should be undertaken under the in-tended load conditions and duty cycles (monitoring the oil temperature), if such throttle devices are utilized and / or the load period is above 30% per cycle.

$$\vartheta_{oil B} \approx \Delta\vartheta_B + \vartheta_U$$

$$\% ED = \frac{t_B}{t_B + t_A} \cdot 100$$

- $\vartheta_{oil B}$ (°C) = Persistent temperature of the fluid filling (max. approx. 80°C)
- $\Delta\vartheta_B$ (K) = Inertia excess temperature depending on load, see rough calculation
- ϑ_U (°C) = Ambient temperature in the surrounding area of the compact hydraulic power pack
- p_m (bar) = Calculated average pressure per duty cycle $T = t_B + t_A$ (representing the load conditions only)
- t_B (s) = Load period per cycle
- t_A (s) = Period of standstill per cycle
- $t_{1,2,3...}$ (s) = Periods for pressure $p_{1,2,3...}$ within the load period t_B
- $p_{1,2,3...}$ (bar) = Pressure during periods $t_{1,2,3...}$ within the load period t_B
- $\% ED$ (-) = Relative load period per cycle

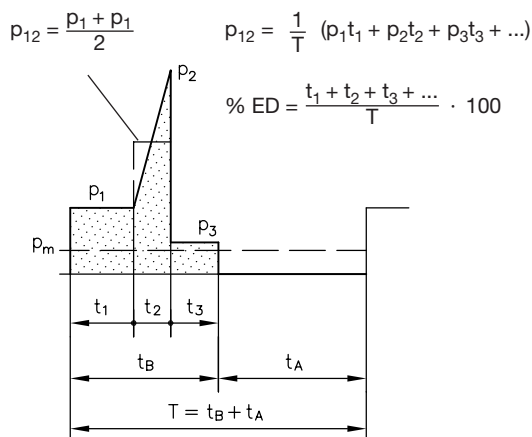

Example: MPN 44 - H 1.6 - B10.20 - 3 x 400/230 V 50 Hz
 (p_{max} = 600 bar)
 Given p₁ = 480 bar t₁ = 20s
 p₂ = 600 bar t₂ = 12s
 p₃ = 440 bar t₃ = 13s
 Cycle period T = 75s
 V_g = 1.19 cm³/rev.

Found $p_m = \left(480 \cdot 20 + \frac{480 + 600}{2} \cdot 12 + 430 \cdot 13 \right) = 290.7$ bar (only calculated) $(p_m \cdot V_g) = 1.19 \cdot 290.7 \approx 346$ bar cm³

$\% ED = \frac{20 + 12 + 13}{75} \cdot 100 = 60\%$

Curves illustrating a guideline of the excess temperature in dependence of the tank size and the aver. hydraulic work

Tank B10

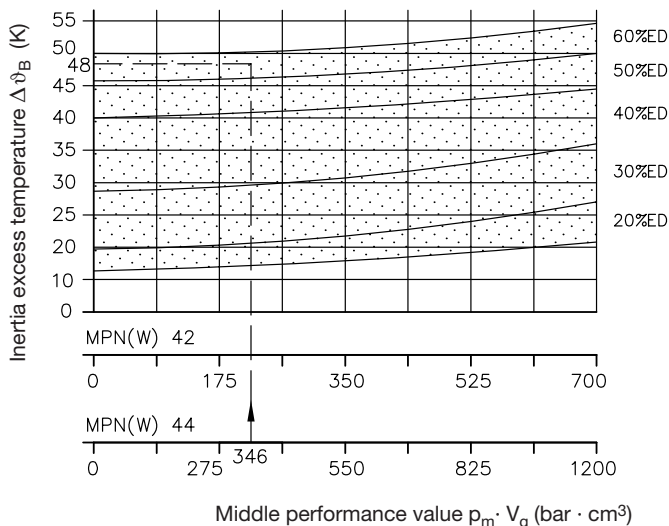

The curve for B10, shows that a MPN 44 at 60% ED and a $p_m V_g = 346$ will have an inertia excess temperature of about $\Delta\vartheta_B \approx 48^\circ\text{C}$.

Taking into account an ambient temperature of 25°C will lead to a persistent temperature of approx. $\vartheta_{oil B} \approx 25 + 48 \approx 73^\circ\text{C}$.

Design and flow will influence the inertia excess temperature within a certain ED-range.

Tendency:

- Q_{pu} > 8 lpm in the upper range
- Motor speed > 2700 rpm in the upper range
- Motor speed range 1350 ... 1800 rpm in the lower range

Continuation page 26

Tank B 25

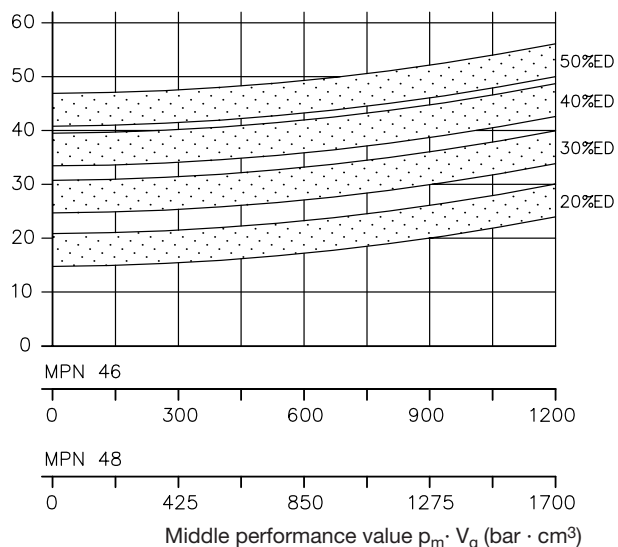
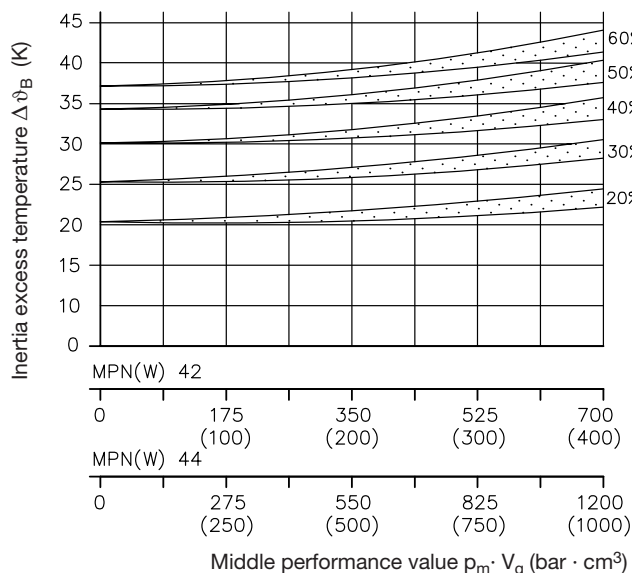

Tank B 55

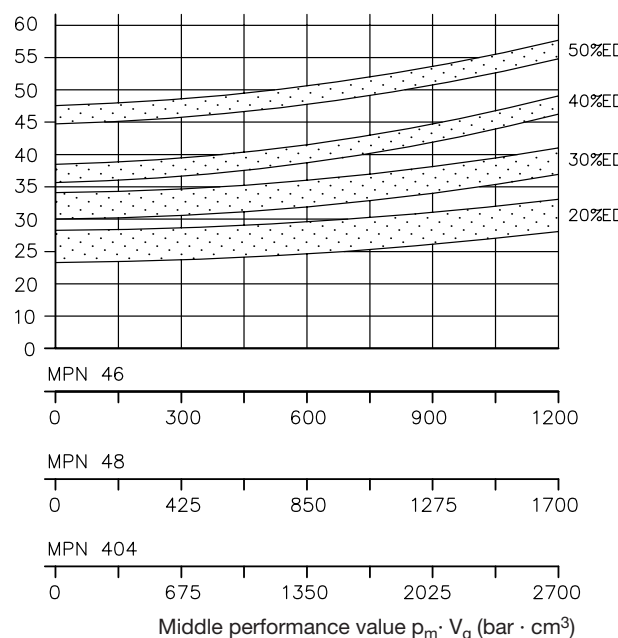
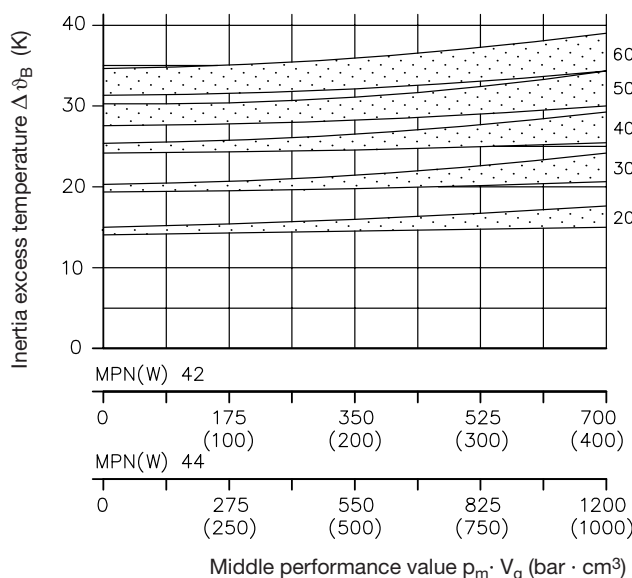

Tank B 110

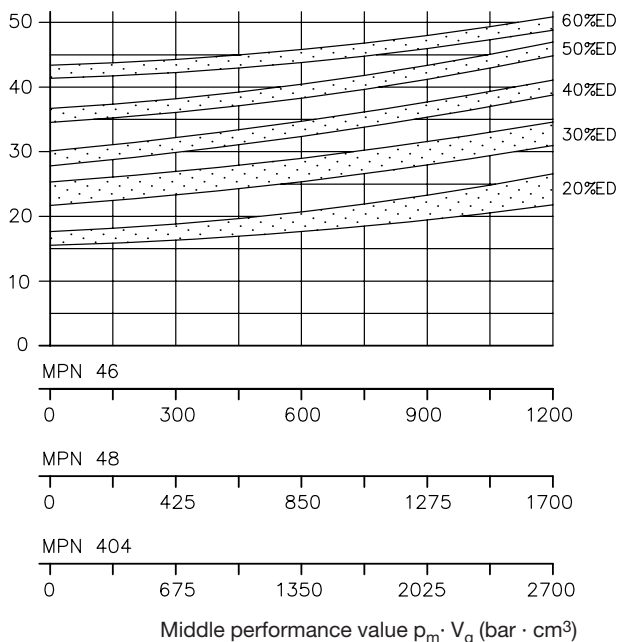
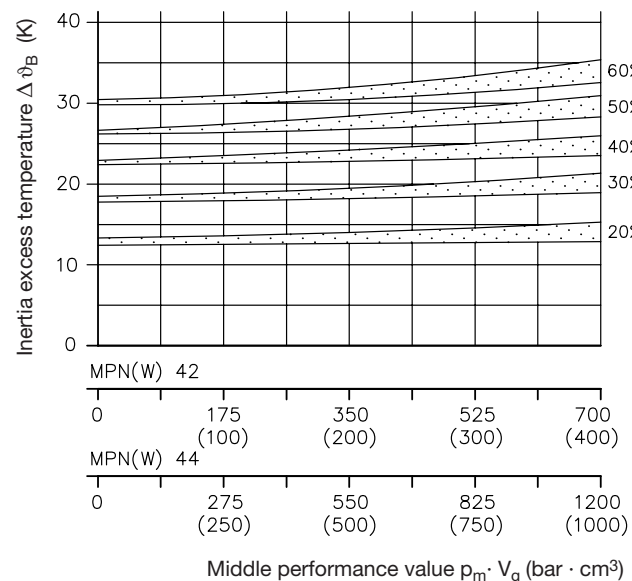

5.6 Motor safeguarding against over heating (protective motor switch)

The protective motor switch has to be adjusted in such a manner, that too early triggering is avoided during undisturbed operation and operation cycles permanently succeeding one another. Whereas it should safeguard the motor against over heating in case of stand-still due to a pressure limiting valve being adjusted to high, malfunction of a pressure switch which should trigger a stop signal etc. Guideline for proper setting of the protective switch: I_E should be $0.7 I_M$ in general, $0.65 I_M$ for operation in the range of p_{max} and $0.8 I_M$ for low loads. The motor current I_M can be read for various pressure settings of the pressure limiting valve in sect. 5.4.

Note: For temperature supervision of hydraulic power packs, see table 4 in sect. 2 !

5.7 Running noise

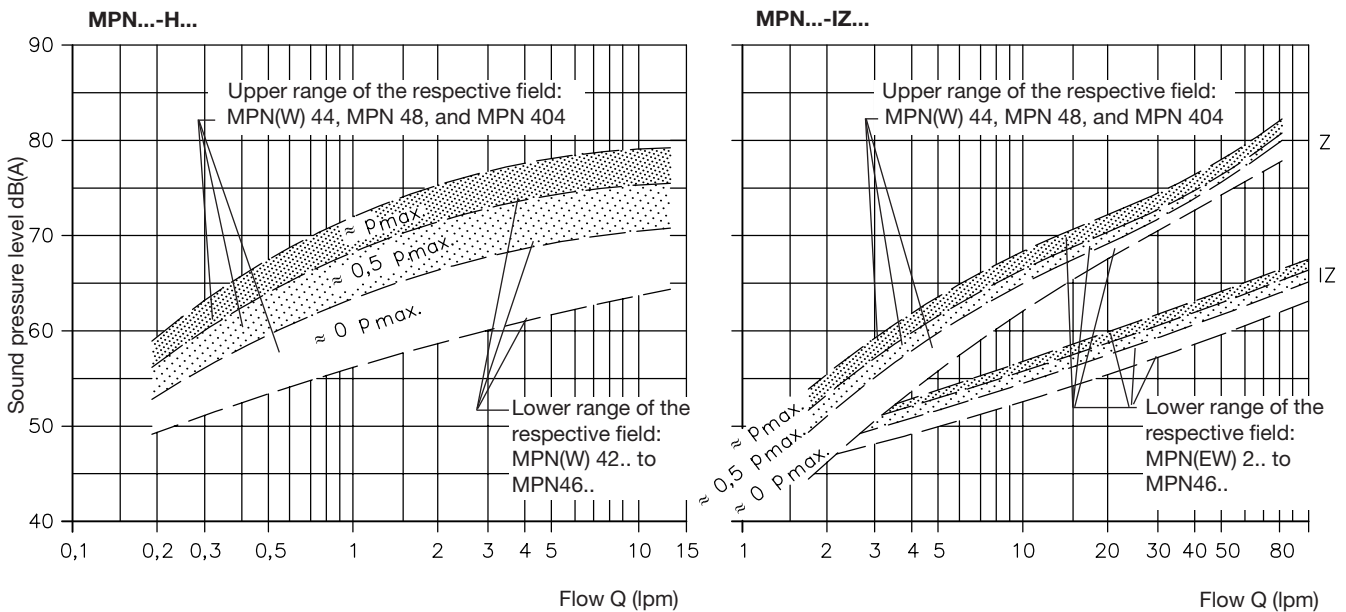

Note:

The sound pressure level ranges shall serve to estimate the running noise to be expected. They approximately delimit the spreads recognizable during measuring. Pumps with smaller delivery flows tend as a rule to the lower, whereas larger ones tend to the upper limit. The noise level of dual circuit pumps is rather similar to the one of the bigger of the two pumps.

The hydraulic power pack should be mounted on „silent blocks“ to prevent or minimize the conduction of body sound onto other sound radiating machinery parts. Pipes to the consumers should be connected via short hoses to the hydraulic power unit. We recommend to mount the hydraulic power pack via “silent blocs“. Further details may be found in the technical information of the respective manufacturer.

Measuring conditions:	Quiet work room, interference level approx. 32 dB(A); measuring point 1m above the floor; 1m object clearance, pump standing on a sound deadening panel (height 50 mm).
Object:	Hydraulic power pack featuring a standard HAWE tank (complete power pack)
Measuring device:	Precision sound pressure level measuring instrument IEC 651 Kl. I
Fluid viscosity during tests:	50 mm ² /s

5.8 Notes to ensure EMC (electromagnetic compatibility)

No impermissible spikes are emitted (EN 60034-1 sect. 19) when hydraulic power packs (inductive motor acc. to EN 60034-1 sect. 12.1.2.1) are connected to a system (e.g. power supply acc. to EN 60034-1 sect. 6).

Tests regarding the conformity with EN 60034-1 sect. 12.1.2.1 and/or VDE 0530-1 are not required.

Electro-magnetic fields may be generated during switching the motor On/Off. This effect can be minimized by means of a filter e.g. type 23140, 3 · 400V AC 4kW 50-60 Hz (Co. Murr-Elektronik, D-71570 Oppenweiler)

6. Suction parts for MP.-Z. required for installation in customer furnished tanks

These suction parts enable lowering of the fluid level below the level where the pump positioned thereby exceeding the usable volume.

The sucking parts are delivered as unassembled component parts. The thread connections have to be sealed very carefully to avoid migration of air. Best apply common PTFE seal tape starting after the 2. or 3. pitches of the fittings' conical thread thereby preventing sheared-off parts of the tape intruding the hydraulic circuit.

The heat built-up of the motor winding must be checked via resistance tests for pumps with little flow/higher pressure if the fluid drops below the motor outline during operation.

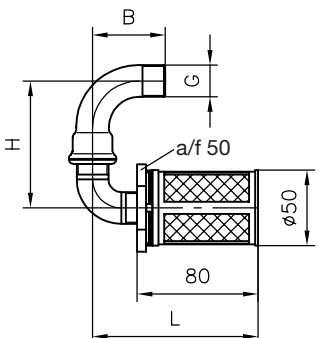
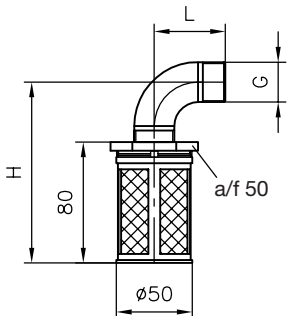
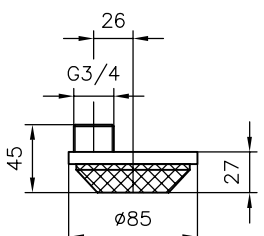
Drawing No. (for pump type)	Main dimensions (mm)			Components		
	Illustration	G (BSPP)	H	L (B)	Sucking screen (HAWE-No.)	Fitting (HAWE-No.)
Dwg. No. 7207 730 O (MPN(W) 4.-Z) ((BG.1) with -D10)		G 3/8	71	105 (42)	3002 5002-00+ 3002 5007-00	6045 1202-00 6045 1116-00
Dwg. No. 7207 730 P (MPN(W) 4.-Z) (9+12.3 with -D10)		G 1/2	84	109.5 (48)	3002 5002-00+ 3002 5005-00	6045 1117-00 6045 1103-00
Dwg. No. 7207 730 A (MPN(W) 4.-Z) (BG.1)		G 3/8	116	42	3002 5002-00+ 3002 5007-00	6045 1198-00
Dwg. No. 7207 730 B (MPN(W) 4.-Z) (9+12.3)		G 1/2	120.5	48	3002 5002-00+ 3002 5005-00	6045 1197-00
Dwg. No. 7207 730 C (MPN(W) 4.-Z1) (6 ... 28+45)		G 3/4	119.5	47	3002 5002-00+ 3002 5004-00	6045 1196-00
Dwg. No. 7207 730 D (MPN(W) 4.-Z) (37+59+75)		G 1	118	47	3002 5002-00+ 3002 5003-00	6045 1195-00
Dwg. No. 7207 730 Q (MPN(W) 4.-Z) (16+21-D10)		G 3/4	45	26	3002 5013-00	

Continuation of the table on page 29

Drawing No. (for pump type)	Main dimensions (mm)			Components			
	Illustration	G (BSPP)	H	L	Sucking screen (HAWE-No.)	Fitting (HAWE-No.)	Adaptor (HAWE-No.)
Dwg. No. 7207 730 E (MPN(W) 4.-HZ) (BG.1)			311	68.5	3002 5002-00+ 3002 5007-00	6045 1108-00	6045 0907-00 6045 0503-00
Dwg. No. 7207 730 F (MPN(W) 4.-HZ) (9+12.3)		G 3/8	307	77.5	3002 5002-00+ 3002 5005-00	6045 1193-00	6045 0911-00
Dwg. No. 7207 730 G (MPN(W) 4.-HZ) (16 ... 28)		G 3/4	314	60	3002 5002-00+ 3002 5004-00	6045 1112-00	6045 1001-00
Dwg. No. 7207 730 K (MPN(W) 4.-HZ) (/37 with -D25)		G 1	333.7	83	3002 5002-00+ 3002 5003-00	6045 1115-00+ 6045 1102-00	6045 0999-00
Dwg. No. 7207 730 L (MPN(W) 4.-HZ) (/37)		G 1	301	63	3002 5002-00+ 3002 5003-00	6045 1102-00	6045 0999-00
Dwg. No. 7207 730 H (MPN(W) 4.-HZ) (/45)		G 3/4	295	50	3002 5002-00+ 3002 5004-00	6045 1199-00	6045 1001-00
Dwg. No. 7207 730 I (MPN(W) 4.-HZ) (/59 + 75)		G 1 1/4	276		3002 5002-00+ 3002 5003-00	6045 1704-00	6045 0999-00
Dwg. No. 7207 730 N (MPN(W) 4.-Z) (/87)			74	22	3002 5015-00		
Dwg. No. 7207 730 M (MPN(W) 4.-HZ) (/87)		G 1 1/4	303	60	3002 5015-00	6045 1799-00+ 6045 1194-00	6045 0902-00
MPN(W) 4.-IZ	see page 15						